

Technical Features

- › Direct acting, directional control valve with bankable mounting interface
- › Designed to be assembled in series or parallel, mounting up to 8 body modules
- › High transmitted hydraulic power up to 250 bar, optimized design to minimize the pressure drop
- › Housing with three chambers for production cost savings
- › The valve is available with interchangeable DC solenoids
- › Wide range of solenoid electrical terminal versions available
- › Wide range of interchangeable spools and manual overrides available
- › Suitable for compact applications in the mobile and mini-power pack industries
- › Space and cost saving! With optional end valves
- › No need for bar manifold to construct complex circuit assemblies from stock
- › In the standard version, the valve housing is phosphated and steel parts are zinc-coated for 240 h protection acc. to ISO 9227
- › Enhanced surface protection for mobile sector up to 520h salt spray acc to ISO 9227 available

Technical Data

Valve size	03		
Max. flow	l/min (GPM)	20 (5.3)	
Max. operating pressure at port P, A, B	bar (PSI)	250 (3630)	
Max. operating pressure at port T	bar (PSI)	210 (3050)	
Fluid temperature range (NBR)	°C (°F)	-30 ... +80 (-22 ... +176)	
Fluid temperature range (FPM)	°C (°F)	-20 ... +80 (-4 ... +176)	
Ambient temperature range	°C (°F)	-30 ... +50 (-22 ... +122)	
Supply voltage tolerance	%	DC: ±10	
Max. switching frequency	1/h	15 000	
Switching time at $v=32$ mm ² /s (156 SUS)	ON	ms	30 ... 50
	OFF	ms	30 ... 50
Mass	- valve with 1 solenoid	kg (lbs)	0.90 (1.98)
	- valve with 2 solenoids		1.05 (2.32)
	Data Sheet	Type	
General information	GI_0060	Products and operating conditions	
Coil types / connectors	C_8007 / K_8008	C14B* / K*	
Mounting interface	SMT_0019	Size 03	
Spare parts	SP_8010		

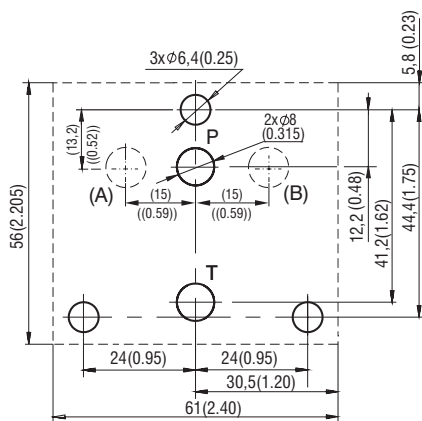

Characteristics measured at $v = 32$ mm²/s (156 SUS)

Operating limits

Operating limits for maximum hydraulic power at rated temperature and supplied with voltage equal to 90 % of the nominal value

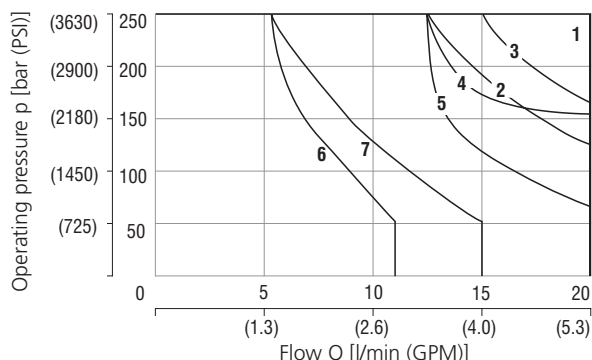

Spool symbol	
Z11, Z51, R11, P11	1
C11, C51, X11	2
H11, Y11, H51	3
C11, Y11, Y51	4
R21	5
A51, Y82	6
Z81	7

Pressure drop related to flow rate

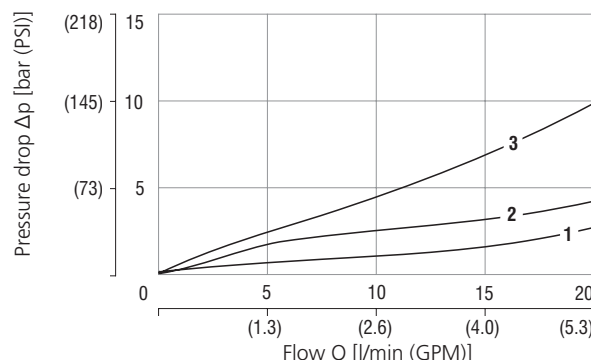

Spool symbol	P-A	P-B	A-T	B-T	P-T
Z11, Y11, P11	1	1	1	1	
R11, R21, X11	2	2	2	2	
Y51, Z51		1	1		
C11	3	3	3	3	2
H11, H51	1	1	1	1	2
C51	3			3	2
A51	2	2			
X11	2	2	2	2	
Y82	2	2	1	3	
Z81			1	2	

For operating limits under conditions other than shown consult our technical department. Admissible operating limits may be considerably lower with only one direction of flow (A or B plugged or without flow).

Design Forms G (S), O in millimeters (inches)

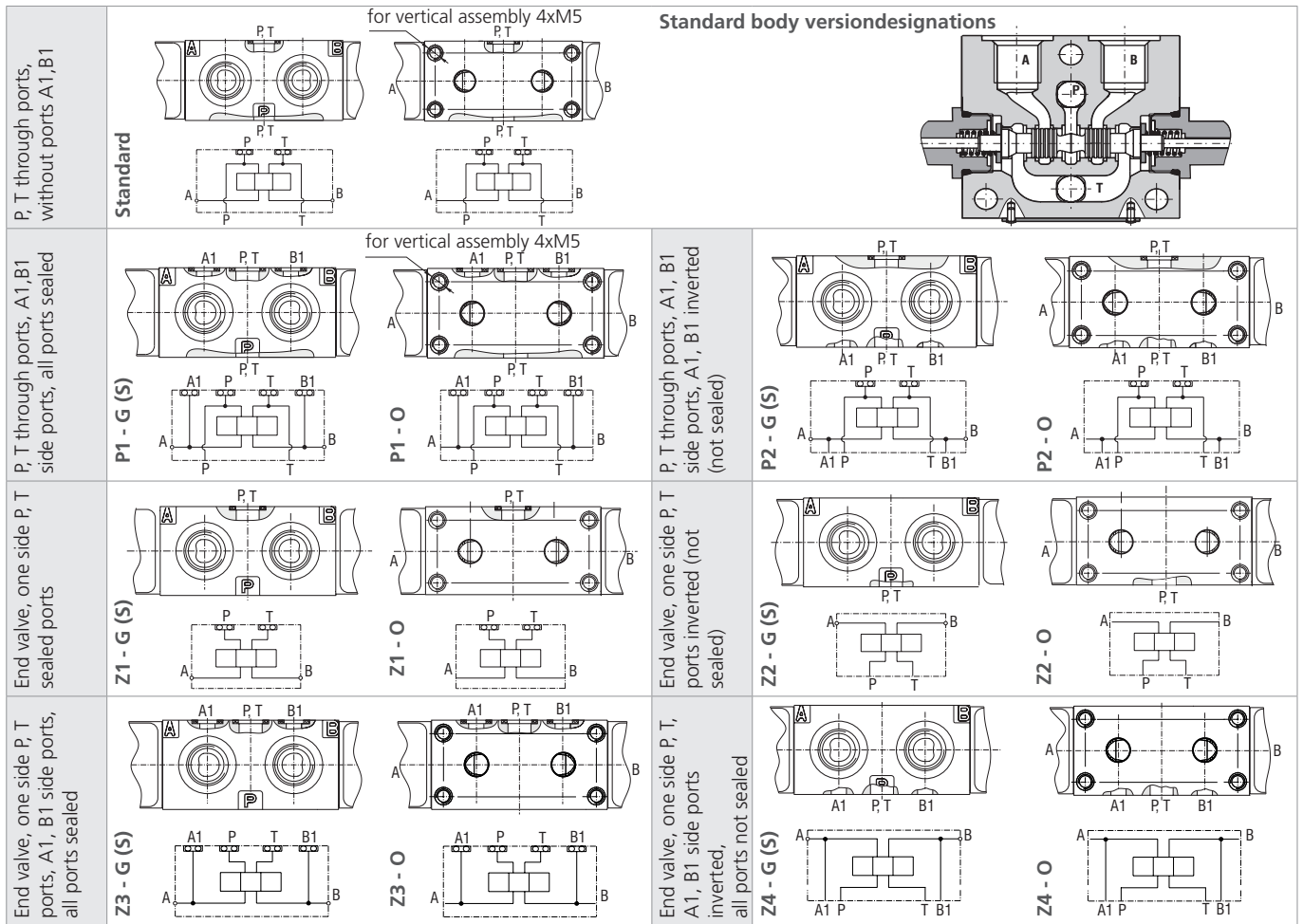

Dimensions in millimeters (inches)

Body version P1 - G (S)
Valve with two solenoids

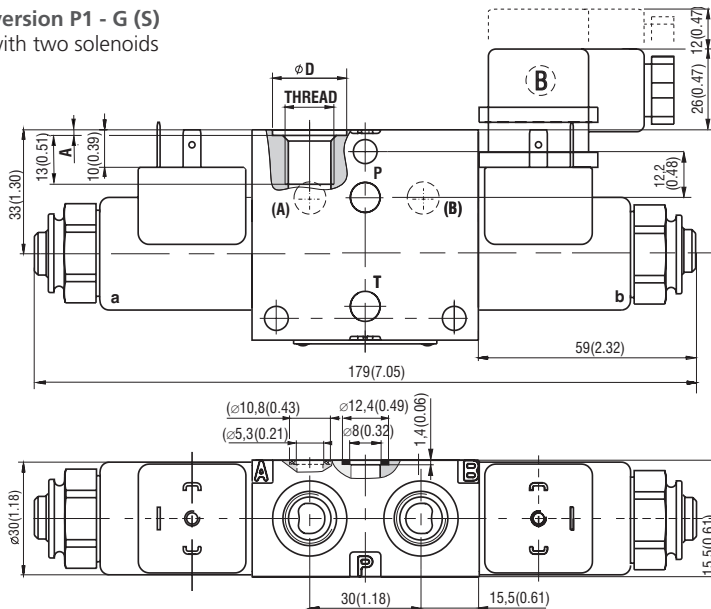

Body version P1 - O
Stackable version

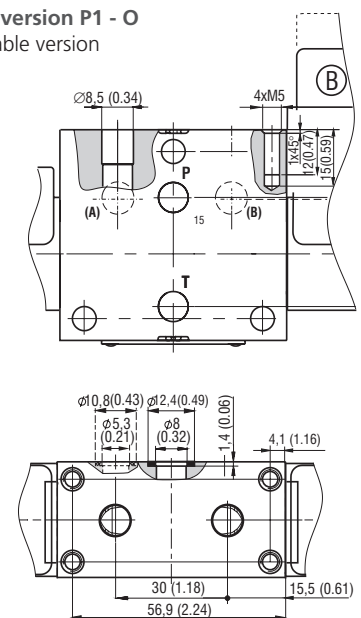

Valve with one solenoid „a“
Spool symbols R11, R21, Y51, C51, Z51

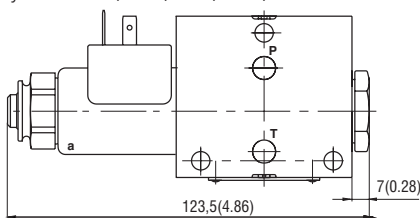

Valve with one solenoid „b“
Spool symbols H11

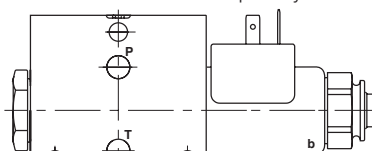

	G	S
THREAD	G1/4	SAE6-9/16-18UNF
∅ D [mm]	20.9H13	25+0.5
∅ D [in]	0.823	0.984+0.02
A [mm (in)]	1 (0.039)	0.5 (0.020)

VERSION - valve with inlet block and pressure relief valve see datasheet 4057 - RPEK1-03/B

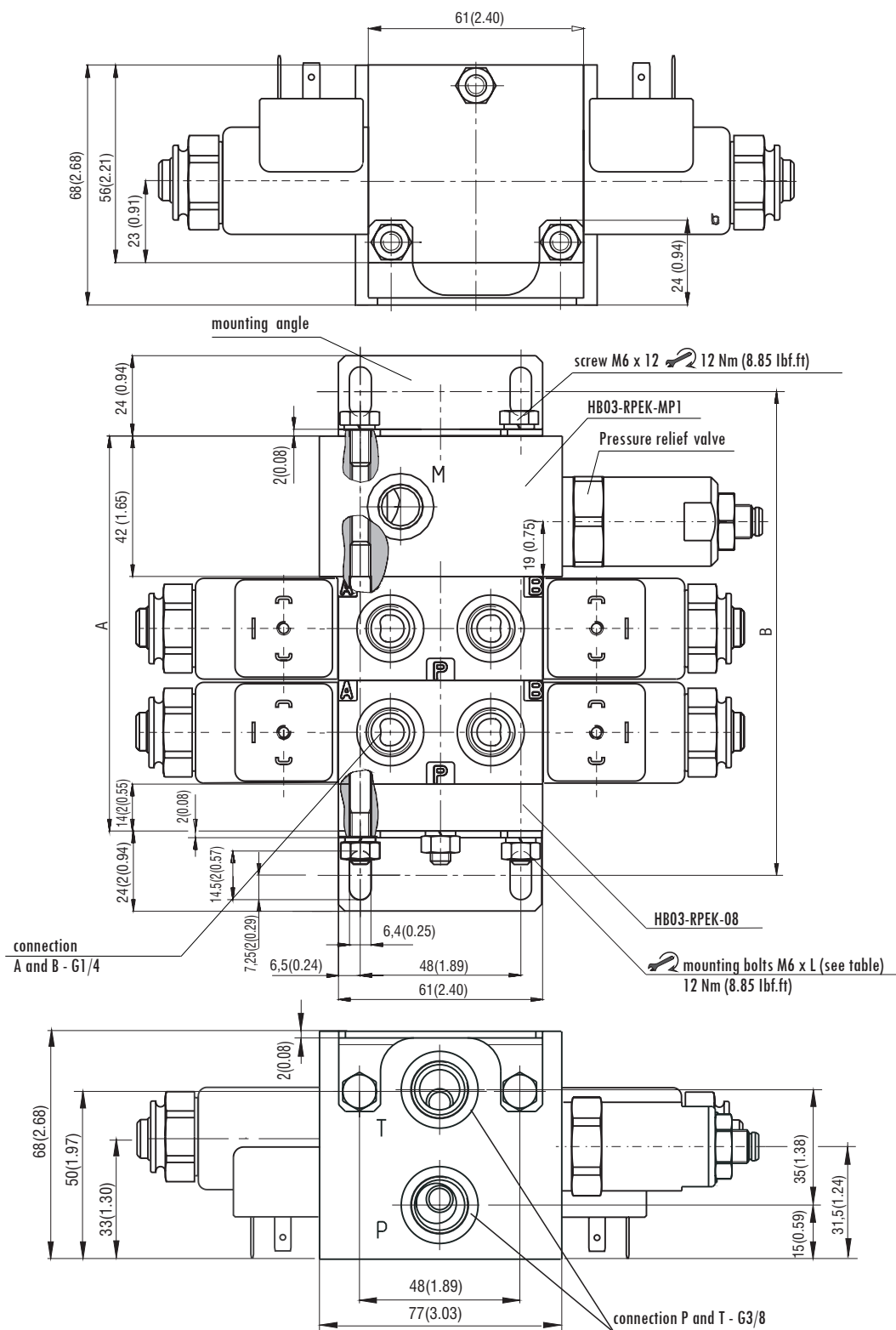

Dimensions mm (inches)								
Number of sections	1	2	3	4	5	6	7	8
Dimension A	87 (3.43)	118 (4.65)	149 (5.87)	180 (7.09)	211 (8.31)	242 (9.53)	273 (10.75)	304 (11.97)
Dimension B	114 (4.49)	145 (5.71)	176 (6.93)	207 (8.15)	238 (9.37)	269 (10.59)	300 (11.81)	331 (13.03)
Dimension L	60 (2.36)	100 (3.94)	133 (5.24)	163 (6.42)	194 (7.64)	224 (8.82)	256 (10.08)	287 (11.30)

RPEL1-04

Size 04 (D02) • Q_{max} 30 l/min (8 GPM) • p_{max} 250 bar (3600 PSI)

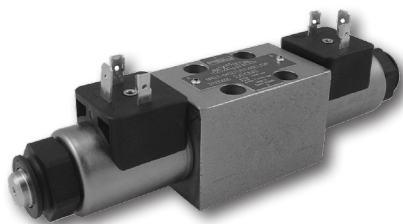

Technical Features

- > Direct acting, directional control valve with subplate mounting surface acc. to ISO 4401, DIN 24340 (CETOP 02)
- > Compact design with reduced solenoid dimensions
- > Three chamber housing design for production cost saving
- > The valve is available with DC solenoids and a wide range of electrical terminals
- > Solenoid electrical terminal options acc. to EN 175301-803-A, AMP Junior Timer and Deutsch DT04-2P
- > Wide range of interchangeable spools and manual overrides available
- > The coil is fastened to the core tube by a retaining nut, and can be rotated by 360° to suit the available space.
- > In the standard version, the valve housing is phosphated and steel parts zinc-coated for 240 h salt spray protection acc. to ISO 9227
- > Enhanced surface protection for mobile sector available (ISO 9227, 520 h salt spray)

ISO 4401-02-01-0-05

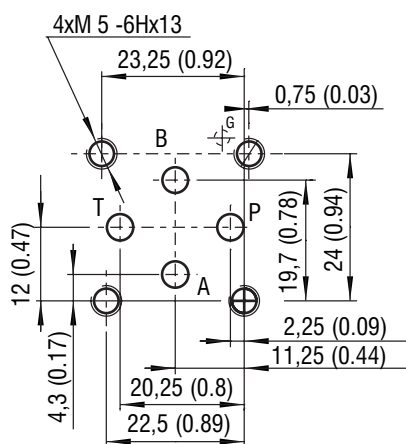

Technical Data

Valve size	04 (D02)		
Max. flow	l/min (GPM)	30 (8)	
Max. operating pressure at ports P, A, B	bar (PSI)	250 (3630)	
Max. operating pressure at port T	bar (PSI)	100 (1450)	
Fluid temperature range (NBR)	°C (°F)	-30 ... +80 (-22 ... +176)	
Fluid temperature range (FPM)	°C (°F)	-20 ... +80 (-4 ... +176)	
Ambient temperature range	°C (°F)	-30 ... +50 (-22 ... +122)	
Supply voltage tolerance	%	DC: ±10	
Max. switching frequency	1/h	10 000	
Switching time at $v=32$ mm ² /s (156 SUS)	ON	ms	DC: 30 ... 50
	OFF	ms	DC: 30 ... 50
Weight	- valve with 1 solenoid	kg (lbs)	0.75 (1.65)
	- valve with 2 solenoids	kg (lbs)	0.9 (1.98)

	Datasheet	Type
General information	GI_0060	Products and operating conditions
Coil types / connectors	C_8007 / K_8008	C 14B*/K*
Mounting interface	SMT_0019	Size 04
Spare parts	SP_8010	

Characteristics measured at $v = 32$ mm²/s (156 SUS)

Operating limits

Operating limits for maximum hydraulic power at rated temperature and supply voltage equal to 90% nominal.

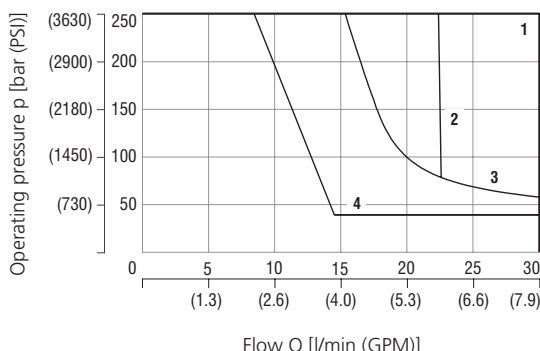

Spool symbol	
Z11, Z51, H11, H51	1
R11, X11	2
Y11, Y51	3
C11, C51	4

For operating limits under conditions and flow directions other than shown contact our technical support.

Pressure drop related to flow rate

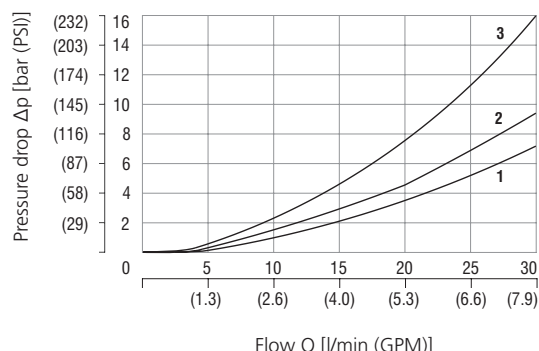

Spool symbol	P-A	P-B	A-T	B-T	P-T
Z11, Y11	1	1	1	1	
R11, X11	2	2	2	2	
Z51, H51, Y51		1	1		
C11	3	3	3	3	2
C51	3			3	2
H11	1	1	1	1	2

Ordering Code

RPEL1-04 / -

4/2 and 4/3 directional control valve, solenoid operated, Lightline

Valve size

Number of valve positions
two positions 2
three positions 3

Spool symbols
see the table "Spool Symbols"

Rated supply voltage of solenoids (at the coil terminal)
12 V DC / 1.83 A
24 V DC / 0.92 A

01200
02400

No designation

A zinc-coated (ZnCr-3), ISO 9227 (240 h)
B zinc-coated (ZnNi), ISO 9227 (520 h)

Surface treatment

standard

No designation
V

Seals
NBR
FPM (Viton)

No designation

N2
N5

Manual override

standard
rubber boot protected
socket head screw

E1
E2
E3A
E4A
E12A
E13A

Connector
EN 175301-803-A
E1 with quenching diode
AMP Junior Timer - axial direction (2 pins; male)
E3A with quenching diode
Deutsch DT04-2P - axial direction (2 pins; male)
E12A with quenching diode

- For directional valves with two solenoids, one solenoid must be de-energized before the other solenoid can be charged.
- For other solenoid voltage supply options see data sheet C_8007.
- The solenoid operated valves are delivered without connectors. For available connectors see data sheet K_8008.
- The orifice to the P port can be ordered separately, see data sheet SP_8010.
- Mounting bolts M5 x 35 DIN 912-10.9 or studs must be ordered separately. Tightening torque is 5 Nm (3.7 lbf.ft).
- Besides the commonly used valve versions shown other special models are available. Contact our technical support for their identification, feasibility and operating limits.

Spool Symbols

Type	Symbol	Interposition	Type	Symbol	Interposition
Z11			Z51		
C11			H51		
H11			Z11		
Y11			X11		
R11			C11		
Y51			H11		
C51			Y11		

Solenoid Coil in millimeters (inches)

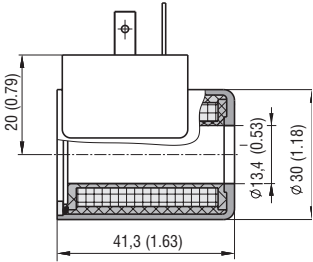
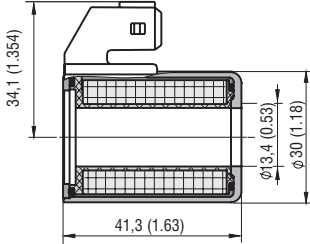
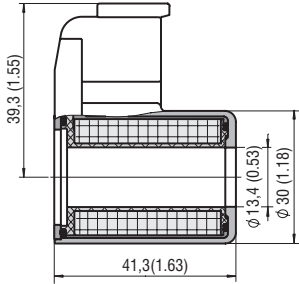
<p>E1 - connector EN 175301-803-A E2 - E1 with quenching diode Protection degree IP65</p>	<p>E3A - AMP Junior Timer (2-pins; male) E4A - E3A with quenching diode Protection degree IP67</p>	<p>E12A - connector Deutsch DT04-2P (2-pins; male) E13A - E12A with quenching diode Protection degree IP67 / IP69K</p>
		

The indicated IP protection level is only achieved if the connector is properly mounted.

Manual Override in millimeters (inches)

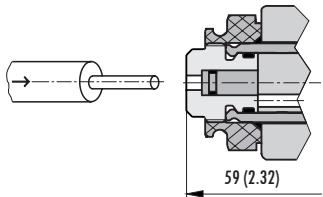
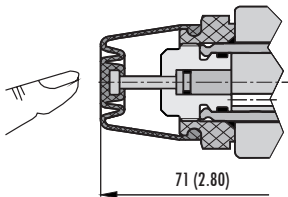
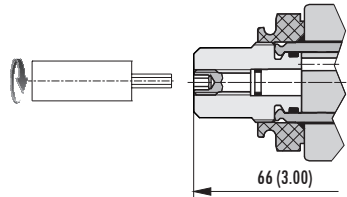
<p>No designation - standard</p>	<p>Designation N2 - protected with rubber boot</p>	<p>Designation N5 - socket head screw 3</p>
		

In case of solenoid malfunction or power failure, the spool of the valve can be shifted by manual override as long as the pressure in port T does not exceed 25 bar (363 PSI). For alternative manual overrides contact our technical support.

Valve Dimension in millimeters (inches)

RPEL1-043x/xE1*

Valve with two solenoids
Spool symbols
Z11, C11, H11, Y11

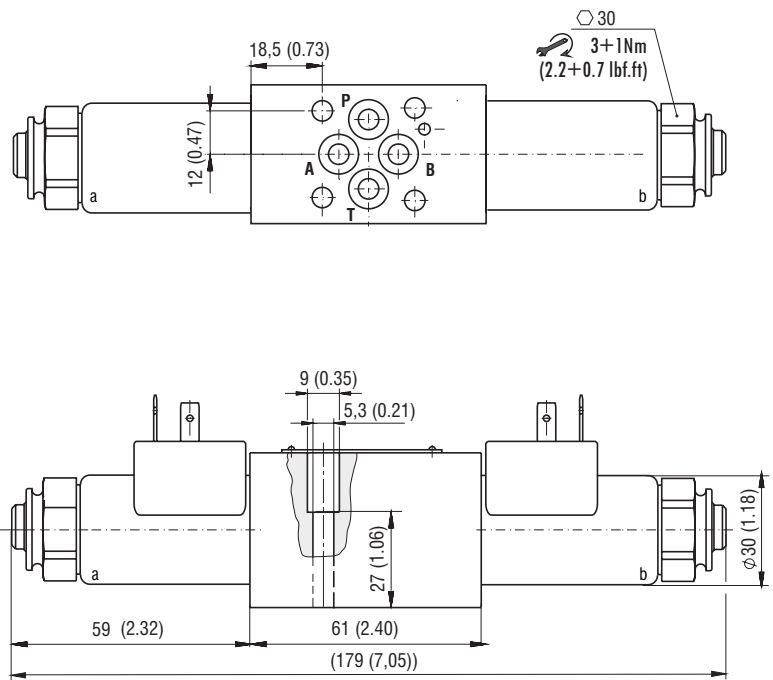

RPEL1-042x/xE1*

Valve with one solenoid „a“
Spool symbols
R11, Y51, C51, Z51, H51

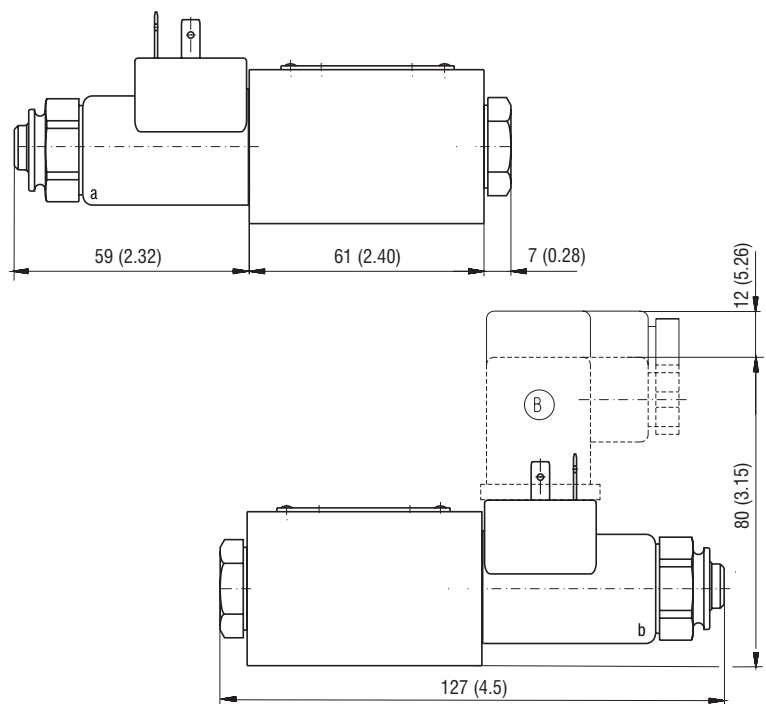
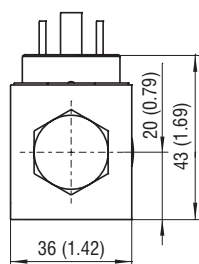

RPEL1-062x/xE1*

Valve with one solenoid „b“
Spool symbols
Z11, X11, C11, H11, Y11

Mounting screws  5 Nm (3.7 lbf.ft)
4x M5 x 35 DIN 912-10.9

4/2 and 4/3 Directional Control Valve, Solenoid Operated

RPE2-04

Size 04 (D02) • Q_{max} 20 l/min (5 GPM) • p_{max} 320 bar (4600 PSI)

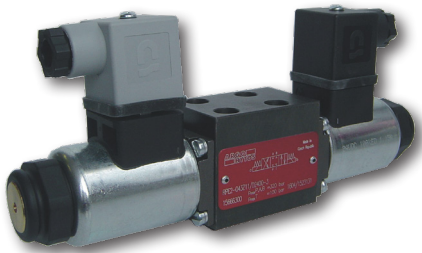

2 - (former CETOP-RP 121H)

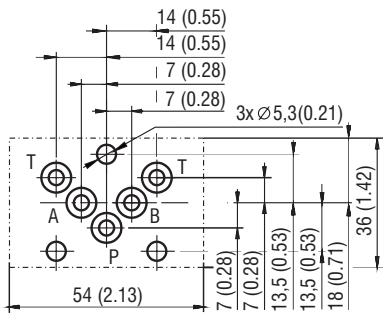

3 - ISO 4401-AA-02-4-A (DIN 24340-A4)

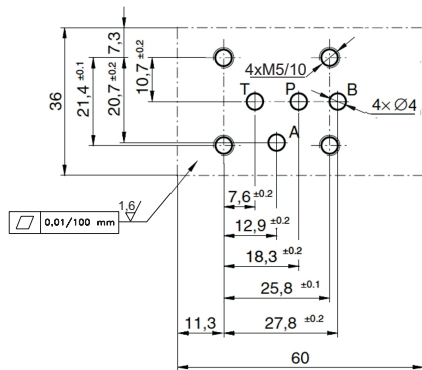

Technical Features

- Direct acting, directional control valve with subplate mounting surface acc. to (CETOP-RP 121H) and ISO 4401-AA-02-4-A (DIN 24340-A4)
- High transmitted hydraulic power up to 320 bar with optimized design to minimize the flow pressure drop
- Three chamber housing design for production cost saving
- The valve is available with interchangeable DC solenoids, also with AC power supply, using a built-in rectifier bridge
- Solenoid electrical terminal option acc. to EN 175301-803-A
- Wide range of interchangeable spools available
- The coil is fastened to the core tube with a retaining nut, and can be rotated by 360°, to suit the available space.
- In the standard version, the valve housing is phosphated and steel parts zinc-coated for 240 h salt spray protection acc. to ISO 9227
- Enhanced surface protection for mobile sector available (ISO 9227, 520 h salt spray)

Technical Data

Valve size		04 (D02)	
Max. flow		20 (5.3)	
Max. operating pressure at port P, A, B	bar (PSI)	320 (4600)	
Max. operating pressure at port T	bar (PSI)	100 (1450)	
Fluid temperature range (NBR)	°C (°F)	-30 ... +80 (-22 ... +176)	
Fluid temperature range (FPM)	°C (°F)	-20 ... +80 (-4 ... +176)	
Ambient temperature range	°C (°F)	-30 ... +50 (-22 ... +122)	
Supply voltage tolerance	%	AC: ±10	DC: ±10
Max. switching frequency	1/h	15 000	
Switching time at $v=32 \text{ mm}^2/\text{s}$ (156 SUS)	ON	30 ... 50	
	OFF	AC: 70 ... 100	DC: 30 ... 50
Weight - valve with 1 solenoid	kg (lbs)	1.1 (2.43)	
- valve with 2 solenoids	kg (lbs)	1.5 (3.31)	

	Datasheet	Type
General information	GI_0060	Products and operating conditions
Coil types / connectors	C_8007 / K_8008	C19B* / K*
Mounting interface	SMT_0019	2 - (Former CETOP-RP 121H) / 3 - ISO 4401-AA-02-4-A (DIN 24340-A4)
Spare parts	SP_8010	

Characteristics measured at $v = 32 \text{ mm}^2/\text{s}$ (156 SUS)

Operating limits

Operating limits for maximum hydraulic power at rated temperature and supply voltage equal to 90% nominal.

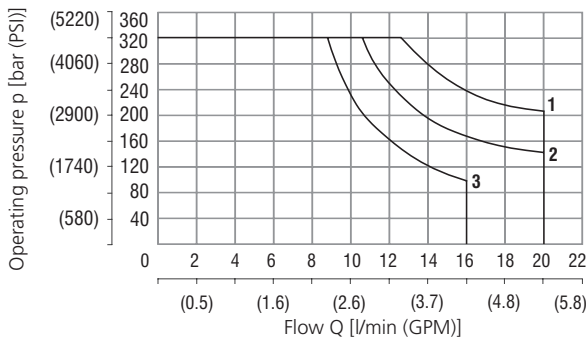

Spool symbol	
1	R11, R21, X11, J75
2	Z11, Z51, H11, P11, P51, Y11, Y51, B11
3	C11, C51, L21, A51, Z71, Z81, J15

For operating limits under conditions and flow directions other than shown contact our technical support.

Pressure drop related to flow rate

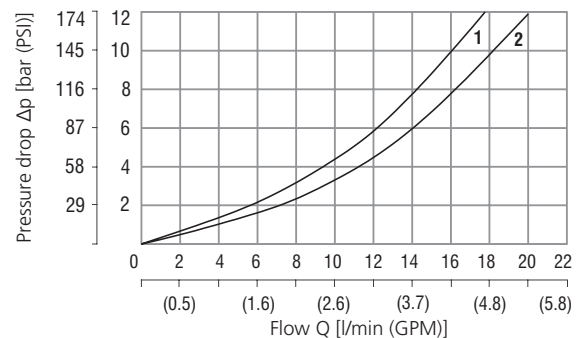

For all Functional Symbols	
P → T	1
P → A	2
P → B	2
A → T	2
B → T	2

Ordering Code

RPE2-04 [] [] / [] [] [] [] - [] []			
4/2 and 4/3 directional control valve, solenoid operated			
Valve size			
Number of valve positions	two positions three positions	2 3	
Spool symbols	see the table "Spool Symbols"		
Rated supply voltage of solenoids (at the coil terminal)	12 V DC / 2.45 A 24 V DC / 1.15 A 27 V DC / 0.89 A 115 V DC / 0.24 A / 50 (60) Hz 230 V AC / 0.12 A / 50 (60) Hz	01200 02400 02700 11550 23050	
			E1 E2
			No designation
			Surface treatment housing phosphated, steel parts zinc-coated (ZnCr-3), ISO 9227 (240 h) zinc-coated (ZnCr-3), ISO 9227 (240 h) zinc-coated (ZnNi), ISO 9227 (520 h)
			Mounting surface 2 acc. to former CETOP-RP 121H 3 acc. to former ISO 4401-AA-02-4-A (DIN 24340-A4)
			Seals NBR
			Manual override standard
			Connector EN 175301-803-A E1 with quenching diode

- For directional valves with two solenoids, one solenoid must be de-energized before the other solenoid can be charged.
- If the pressure exceeds 100 bar with spool types A51 or J75, port T should be connected directly to the tank.
- For other solenoid voltage supply options see data sheet C_8007.
- The solenoid operated valves are delivered without connectors. For available connectors see data sheet K_8008.
- The orifice to the P port can be ordered separately, see data sheet SP_8010.
- Mounting bolts M5 x 35 DIN 912-10.9 or studs must be ordered separately. Tightening torque is 5+1 Nm (3.7+0.7 lbf.ft).
- Besides the commonly used valve versions shown other special models are available. Contact our technical support for their identification, feasibility and operating limits.

Spool Symbols

Type	Symbol	Interposition	Type	Symbol	Interposition	Type	Symbol	Interposition
Z11			R11			C51		
C11			A51			R21		
H11			P51			X11		
P11			Y51			Z11		
Y11			Z51			C11		
L21			Z71			J15		
B11			Z81			J75		

Manual Override in millimeters (inches)

No designation - standard

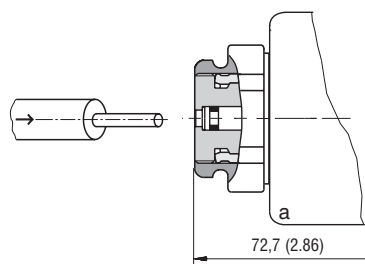

In case of solenoid malfunction or power failure, the spool of the valve can be shifted by manual override as long as the pressure in port T does not exceed 25 bar (363 PSI). For alternative manual overrides contact our technical support.

Dimensions in millimeters (inches)

Installation dimensions 2 (former Norm CETOP-RP 121H)

RPE2-043xx/x*

Valve with two solenoids

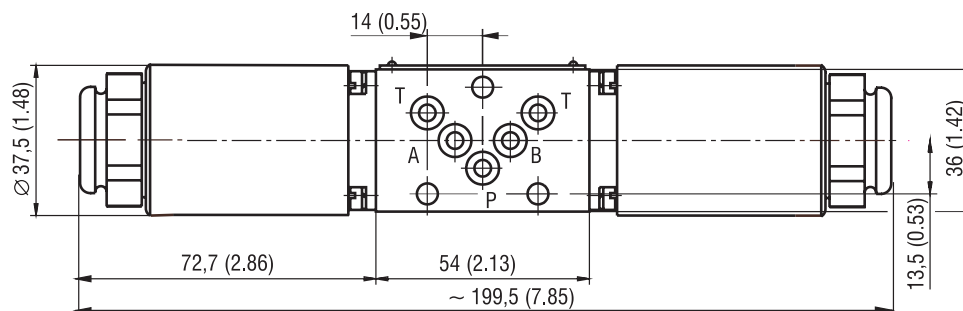
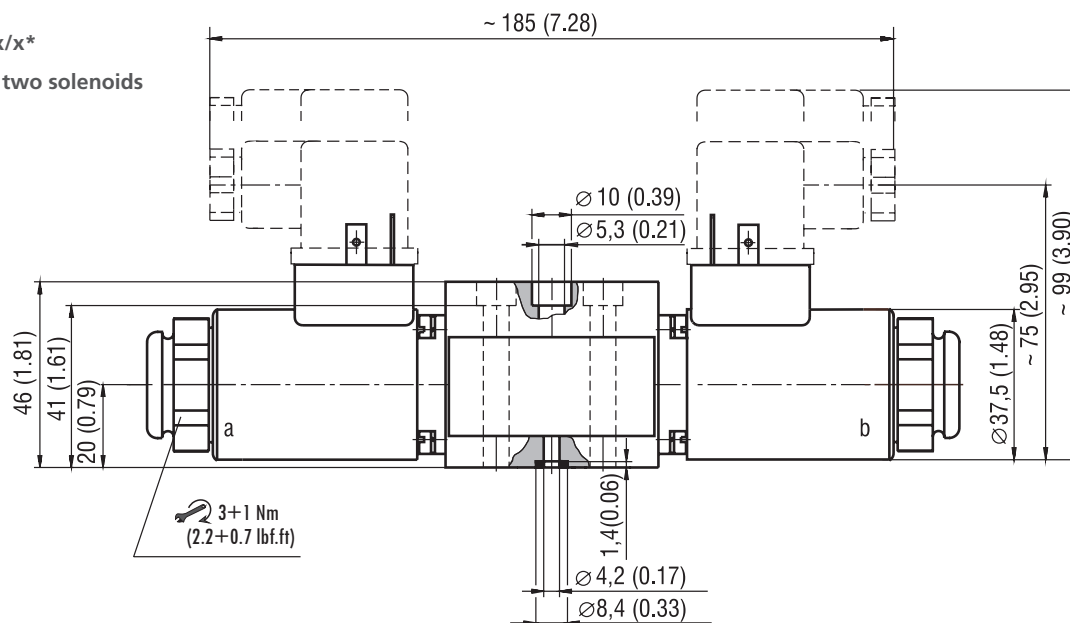

RPE2-042xx/x*

Valve with one solenoid „a“
Spool symbols R11, R21, A51,
P51, Y51, Z51, C51, Z71, Z81

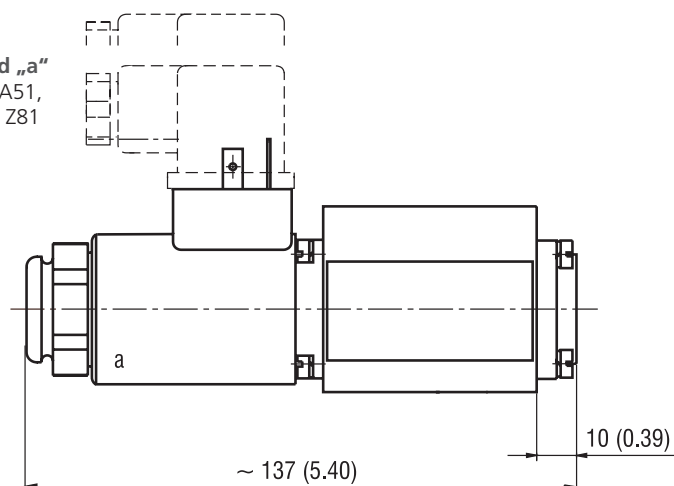

RPE2-042xx/x*

Valve with one solenoid „b“
Spool symbols X11, Z11, C11

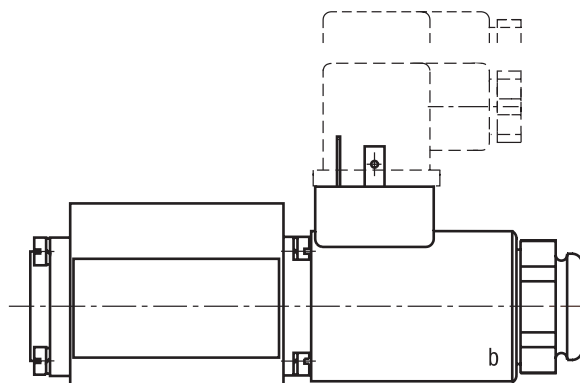

Dimensions in millimeters (inches)

Installation dimensions 3 (former Norm to DIN 24340-A4)

RPE2-043xx/x*

Valve with two solenoids

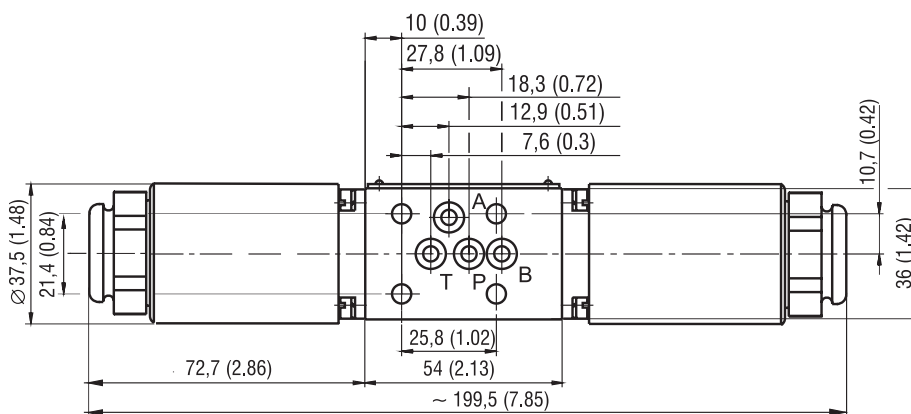
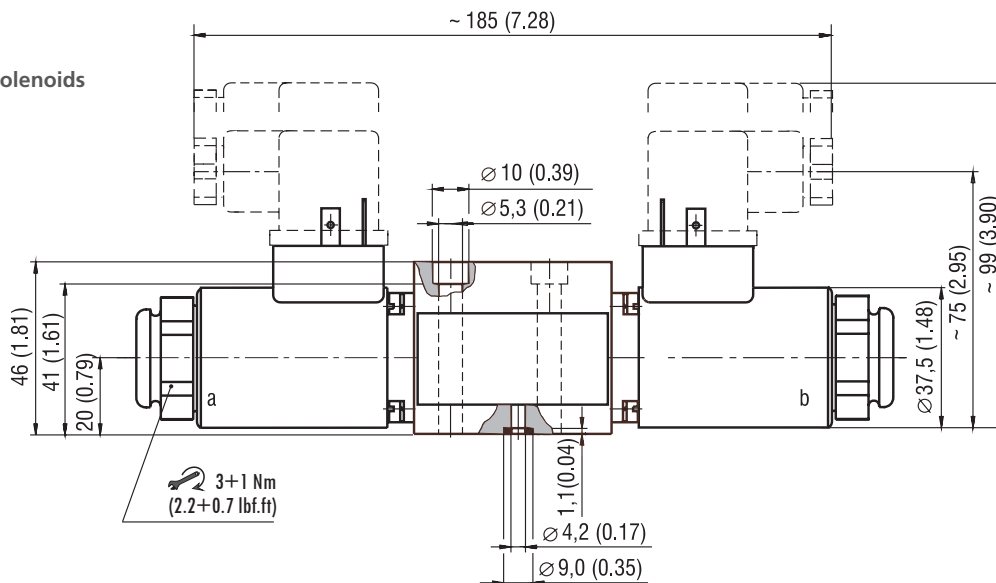

RPE2-042xx/x*

Valve with one solenoid „a“

Spool symbols R11, R21, A51, P51, Y51, Z51, C51, Z71, Z81

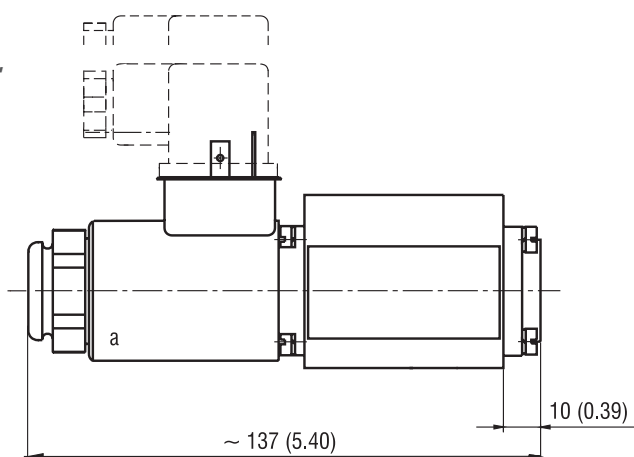

RPE2-042xx/x*

Valve with one solenoid „b“

Spool symbols X11, Z11, C11

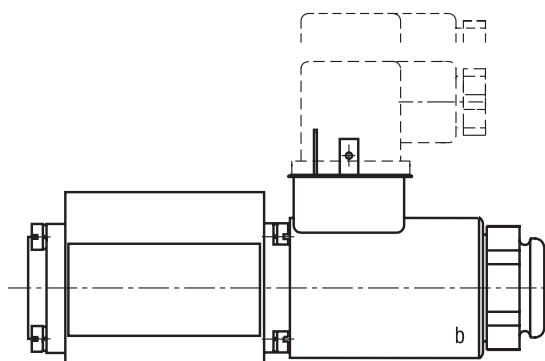

4/2 and 4/3 Directional Control Valve, Solenoid Operated

RPE3-04

Size 04 (D02) • Q_{max} 30 l/min (8 GPM) • p_{max} 320 bar (4600 PSI)

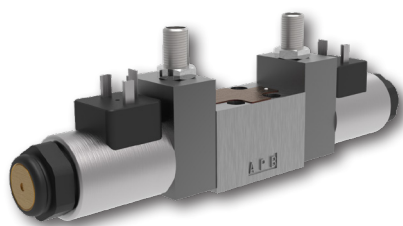

Technical Features

- › Direct acting, directional control valve with subplate mounting interface acc. to ISO 4401, DIN 24340 (CETOP 02)
- › High transmitted hydraulic power up to 320 bar with optimized design to minimize pressure drop
- › Three chamber housing design for production cost saving
- › The coil is fastened to the core tube with a retaining nut and can be rotated by 360° to suit the available space
- › The valve is available with interchangeable DC solenoids, also for AC power supply using a built-in rectifier bridge
- › Wide range of solenoid electrical terminal versions available
- › CSA Certificate upon request
- › Inductive contactless Normally Open and Normally Closed spool position sensor option
- › In the standard version, the valve housing is phosphated and steel parts zinc-coated for 240 h salt spray protection acc. to ISO 9227
- › Enhanced surface protection for mobile sector available (ISO 9227, 520 h salt spray)

ISO 4401-02-01-0-05

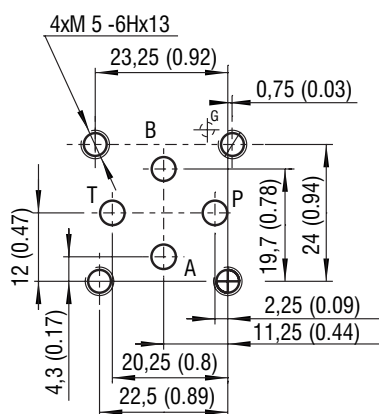

Ports P, A, B, T - max \varnothing 4.5 mm (0.18 in)

Technical Data

Valve size		04 (D02)	
Max. flow	l/min (GPM)	30 (8)	
Max. operating pressure at ports P, A, B	bar (PSI)	320 (4640)	
Max. operating pressure at port T	bar (PSI)	210 (3050)	
Fluid temperature range (NBR)	°C (°F)	-30 ... +80 (-22 ... +176)	
Fluid temperature range (FPM)	°C (°F)	-20 ... +80 (-4 ... +176)	
Ambient temperature range	°C (°F)	-30 ... +50 (-22 ... +122)	
Supply voltage tolerance	%	AC: \pm 10	DC: \pm 10
Max. switching frequency	1/h	15 000	
Switching time at $v=32$ mm ² /s (156 SUS)	ON	ms	30 ... 50
	OFF	ms	AC: 70 ... 100 DC: 30 ... 50
Weight	- valve with 1 solenoid - valve with 2 solenoids	kg (lbs)	0.9 (1.98) 1.3 (2.75)
		Datasheet	Type
General information	GI_0060	Products and operating conditions	
Coil types / connectors	C_8007 / K_8008	C19B* / K*	
Mounting interface / tolerances	SMT_0019	Size 04	
Spare parts	SP_8010		
Subplates	DP_0002	DP*-04	

Characteristics measured at $v = 32$ mm²/s (156 SUS)

Operating limits

Operating limits for maximum hydraulic power at rated temperature and supply voltage equal to 90% nominal.

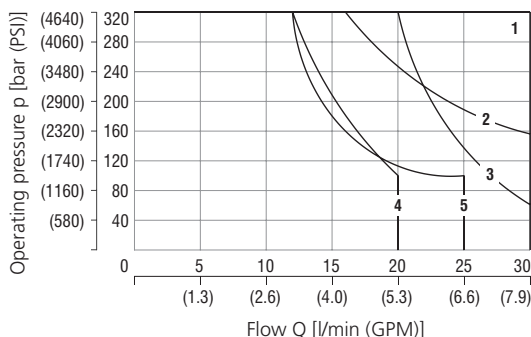

Spool symbol	Spool symbol
1	Z11, Z51, H11, P11, P51, Y11, Y51, B11, R11, X11, J15
2	C11, C51
3	R21
4	L21, A51, J75
5	Y71

Pressure drop related to flow rate

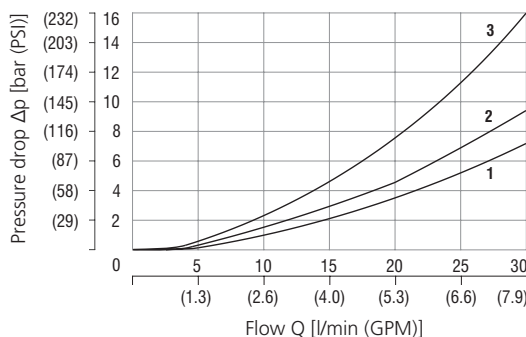

Spool symbol	P-A	P-B	A-T	B-T	P-T	P-A	P-B	A-T	B-T	P-T
Z11, P11, Y11, L21, B11	1	1	1	1		C11	3	3	3	2
R11, R21, X11, J15	2	2	2	2		C51	3		3	2
A51, J75	1	1				H11	1	1	1	2
P51, Y51, Z51		1	1			Y71	2		2	1

For operating limits under conditions and flow directions other than shown contact our technical support.

Ordering Code

RPE3 - 04 / -

4/2 and 4/3 directional control valve, solenoid operated

Valve size

Number of valve positions

two positions **2**
three positions **3**

Spool symbols

see the table "Spool Symbols"

Rated supply voltage of solenoids

(at the coil terminal)

12 V DC / 2.45 A		01200
24 V DC / 1.15 A		02400
27 V DC / 0.89 A		02700
205 V DC / 0.12 A		20500
24 V AC / 1.31 A / 50 (60) Hz		02450
120 V AC / 0.22 A / 50 (60) Hz		12060
230 V AC / 0.12 A / 50 (60) Hz		23050

CSA upon request

No designation
U

CSA Certified
standard
CSA marking

No designation

A zinc-coated (ZnCr-3), ISO 9227 (240 h)
B zinc-coated (ZnNi), ISO 9227 (520 h)

Surface treatment
standard

No designation

S1
S4

Spool monitoring
without sensors
normally-open sensor
normally-closed sensor

No designation
V

Seals
NBR
FPM (Viton)

No designation

N2
N4
N5

Manual override
standard
rubber boot protected
hand screw
socket head screw

E1

E2

E3

E4

E3A

E4A

E5

E8

E9

E12A

E13A

Connector

EN 175301-803-A
E1 with quenching diode
AMP Junior Timer - radial direction
E3 with quenching diode
AMP Junior Timer - axial direction (2 pins; male)
E3A with quenching diode
EN 175301-803-A with integrated rectifier
Loose conductors (two insulated wires)
E8 with quenching diode
Deutsch DT04-2P - axial direction (2 pins; male)
E12A with quenching diode

- For directional valves with two solenoids, one solenoid must be de-energized before the other solenoid can be charged.
- For AC voltage supply use coils with connector type E5.
- For other solenoid voltage supply options see data sheet C_8007.
- The solenoid operated valves are delivered without connectors. For available connectors see data sheet K_8008.
- The orifice to the P port can be ordered separately, see data sheet SP_8010.
- Mounting bolts M5 x 35 DIN 912-10.9 or studs must be ordered separately. Tightening torque is 5 Nm (3.7 lbf.ft).
- Besides the commonly used valve versions shown other special models are available. Contact our technical support for their identification, feasibility and operating limits.

Spool Symbols

Type	Symbol	Interposition	Type	Symbol	Interposition	Type	Symbol	Interposition
Z11			Y71			Z51		
C11			R11			Z11		
H11			R21			X11		
P11			A51			C11		
Y11			P51			H11		
L21			Y51			J15		
B11			C51			J75		

Solenoid Coil in millimeters (inches)

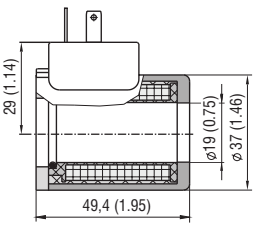
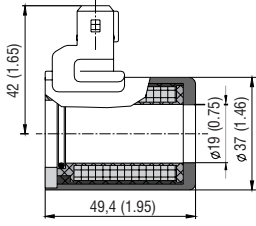
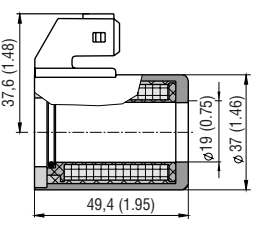
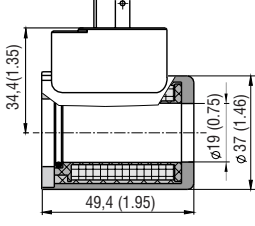
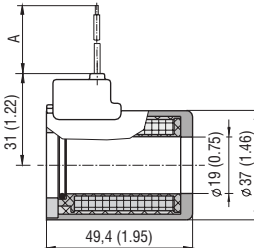
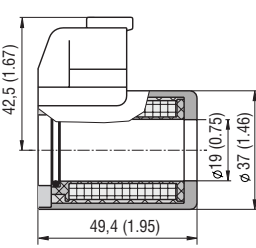
<p>E1, E2 Protection degree IP65</p> 	<p>E3, E4 Protection degree IP67</p> 	<p>E3A, E4A Protection degree IP67</p> 	<p>E5 Protection degree IP65</p> 
<p>E8, E9 Protection degree IP65</p>  <p>Note: A = Standard 300 mm (11.81 in), other lengths on demand</p>		<p>E12A, E13A Protection degree IP67 / IP69K</p> 	

The indicated IP protection level is only achieved if the connector is properly mounted.

Manual Override in millimeters (inches)

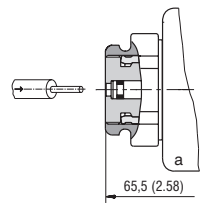
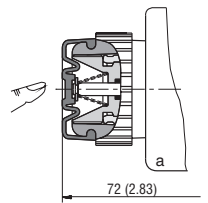
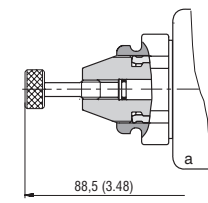
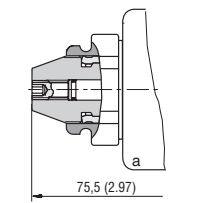
<p>No designation - standard</p> 	<p>Designation N2 - rubber boot protected</p> 	<p>Designation N4 - hand screw</p> 	<p>Designation N5 - socket head screw, size 3</p> 
--	---	---	---

In case of solenoid malfunction or power failure, the spool of the valve can be shifted by manual override as long as the pressure in port T does not exceed 25 bar (363 PSI). For alternative manual overrides contact our technical support.

Spool Position Sensor

S1 - Circuit diagram for the normally - **OPEN** sensor

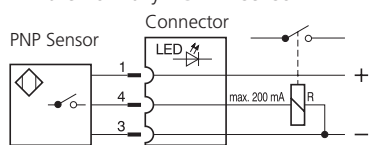

S4 - Circuit diagram for the normally - **CLOSED** sensor

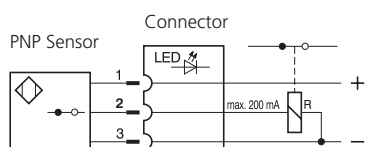

Function of the position sensor:

In the basic position (when the solenoid is switched off), a steel core, connected to the spool, is under the position sensor. The sensor is activated, it means contacts of the sensor S1 are closed and contacts of the sensor S4 are open. After switching on the solenoid the spool with core moves out of the sensor range and the sensor is deactivated.

Technical Data of the Sensor		S1, S4
Rated power supply voltage	V	24 DC
Power supply voltage range	V	10 ... 30 DC
Rated current	mA	200
Sensor enclosure protection (EN 60529)		IP 67
Max. operating pressure	bar (PSI)	210 (3046)
Switching frequency	Hz	1000
Ambient temperature range	°C (°F)	-25 ... +80 (-13 ... +176)
Technical Data of the Connector		
Power supply voltage range	V	10 ... 30 DC
Ambient temperature range	°C (°F)	-25 ... +80 (-13 ... +176)
Indicator		yellow LED

Typical configurations of the valve with a sensor:

3-position valve with two solenoids, equipped with two sensors

2-position valve with one solenoid, equipped with one sensor on the solenoid side

2-position valve with a detent assembly of spool, equipped with one sensor on the side of the solenoid which moves the spool from the basic position to the switched position according to the spool symbol

Note: the sensor always indicates the change of spool position realised by the energised solenoid, mounted on the side of sensor.

①	Signal of solenoid
③	Signal of sensor

Two-Position Directional Control Valve				
① a(b)	③ Sa(Sb)		LED	
	S1	S4	S1	S4
0	1	0	ON	OFF
1	0	1	OFF	ON

Three-Position Directional Control Valve									
① a(b)		③ Sa(Sb)				LED			
		S1		S4		S1		S4	
a	b	Sa	Sb	Sa	Sb	Sa - LED	Sb - LED	Sa - LED	Sb - LED
0	0	1	1	0	0	ON	ON	OFF	OFF
1	0	0	1	1	0	OFF	ON	ON	OFF
0	1	1	0	0	1	ON	OFF	OFF	ON

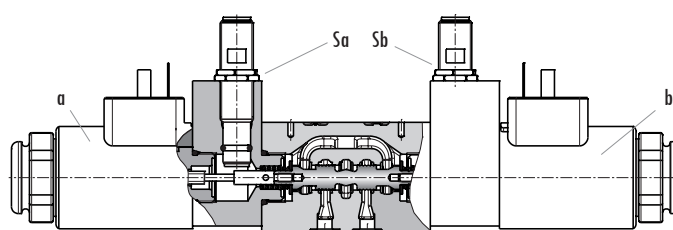
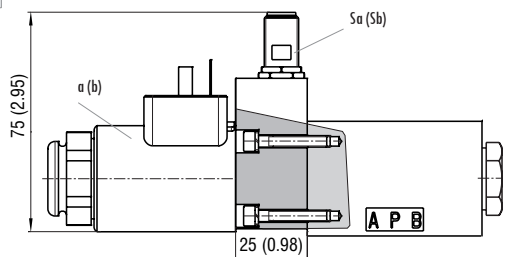

Dimensions in millimeters (inches)

RPE3-043*/E1*

Valve with two solenoids
Spool symbols Z11, C11, H11,
P11, Y11, L21, B11, Y71

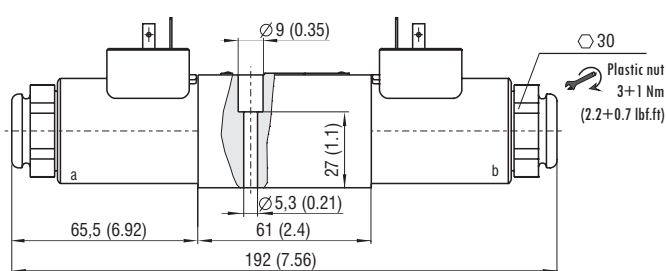
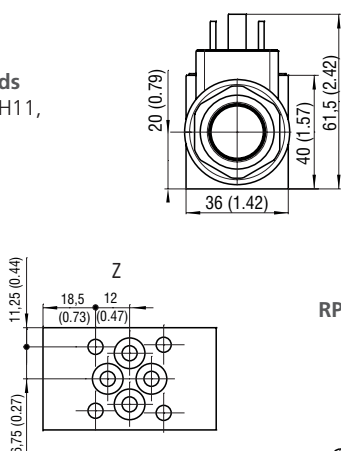

RPE3-043*/E1*S*

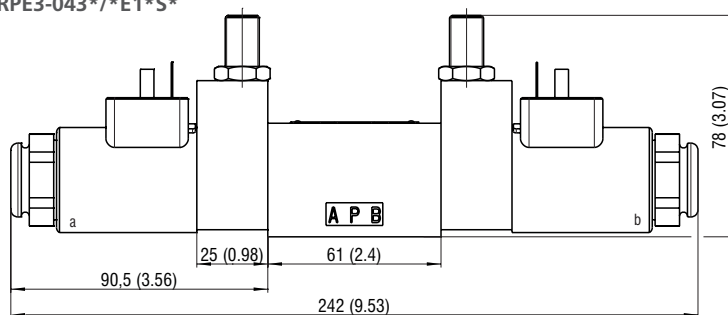

RPE3-042*/E1*

Valve with one solenoid „a“
Spool symbols R11, R21,
A51, P51, Y51, C51, Z51

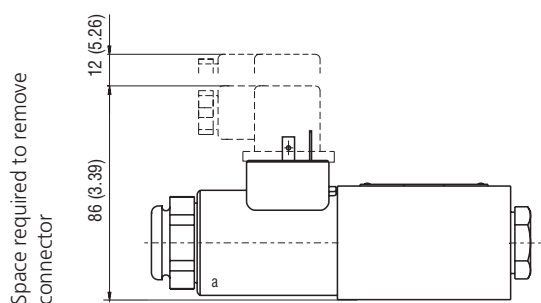

RPE3-042*/E1*

Valve with one solenoid „b“
Spool symbols Z11, X11, C11, H11

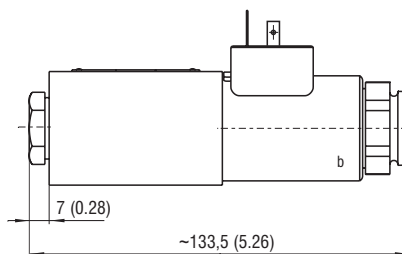

RPE3-042*/E1*S*

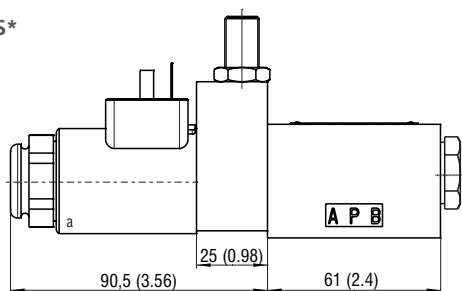

RPE3-042*/E1*S*

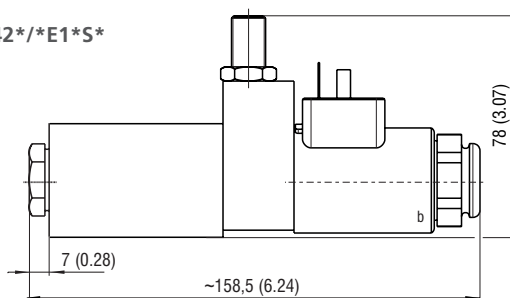

RPEL2-06

Dn 06 (D03) • Q_{max} 60 l/min (16 GPM) • p_{max} 320 bar (4600 PSI)

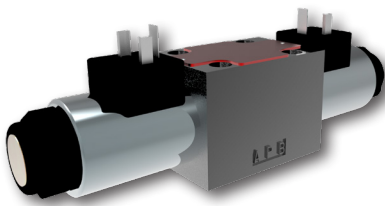

Technical Features

- > Direct acting directional control valve with subplate mounting interface acc. to ISO 4401, DIN 24340 (CETOP 03)
- > Cost-effective Lightline design with reduced solenoid dimensions
- > Five chamber valve design for high transmitted hydraulic power
- > Decreased dependence of function on fluid viscosity
- > Wide range of solenoid electrical terminas and supply voltage types for electromagnets
- > The coil, fastened to the core tube with a retaining nut, can be rotated by 360° to suit the available space
- > Wide range of interchangeable spools
- > In the standard version, the valve housing is phosphated and steel parts zinc-coated for 240 h protection in NSS acc. to ISO 9227.
- > Enhanced surface protection for mobile sector available (520 h in NSS, ISO 9227)

ISO 4401-03-02-0-05

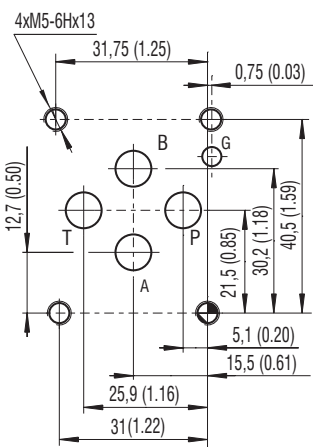

Ports P, A, B, T - max \varnothing 7.5 mm (0.29 in)

Technical Data

Valve size		06 (D03)
Max. flow	l/min (GPM)	60 (15.8)
Max. operating pressure at ports P, A, B	bar (PSI)	320 (4640)
Max. operating pressure at port T	bar (PSI)	210 (3045)
Fluid temperature range (NBR)	°C (°F)	-30 ... +80 (-22 ... +176)
Fluid temperature range (FPM)	°C (°F)	-20 ... +80 (-4 ... +176)
Ambient temperature range	°C (°F)	-30 ... +50 (-22 ... +122)
Supply voltage tolerance	%	DC, AC \pm 10
Max. switching frequency	1/h	10 000
Switching time at $v=32 \text{ mm}^2/\text{s}$ (156 SUS)	ON	ms
	OFF	ms
Weight	- valve with 1 solenoid	kg (lbs)
	- valve with 2 solenoids	kg (lbs)
		1.3 (2.9)
		1.6 (3.5)
Datasheet		Type
General information	GI_0060	Products and operating conditions
Coil types / connectors	C_8007 / K_8008	C19B*/K*
Mounting interface	SMT_0019	Size 06
Spare parts	SP_8010	
Subplates	DP_0002	DP*-06

Characteristics measured at $v = 32 \text{ mm}^2/\text{s}$ (156 SUS)

Operating limits - Power limit characteristics valid for 80% of nominal current.

DC

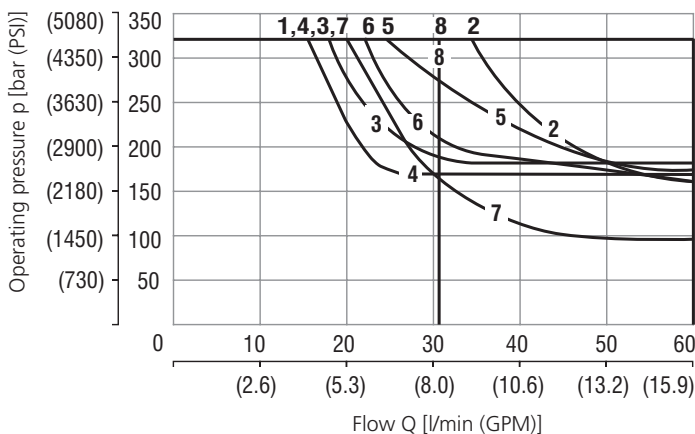

Spool symbol - DC			
1	Z11, Z51, R11, X11, R30, R31, R32, X32, Z71, Z81, Y91	5	R21, X21
2	Y11, Y51	6	Z91
3	C11, C51	7	A51
4	H11, H51	8	Y41, Y82

AC

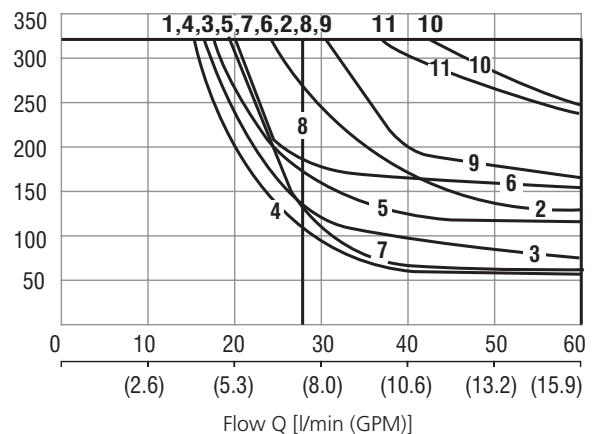

Spool symbol - AC			
1	Z11, Z51, R11, R30, X11, Z71, Z81	5	R21, X21
2	Y11, Y51	6	Z91
3	C11, C51	7	A51
4	H11, H51	8	Y41, Y82
		9	R32, X32
		10	R31
		11	Y91

For operating limits under conditions and flow directions other than shown contact our technical support.

Characteristics measured at $v = 32 \text{ mm}^2/\text{s}$ (156 SUS)

Pressure drop related to flow rate

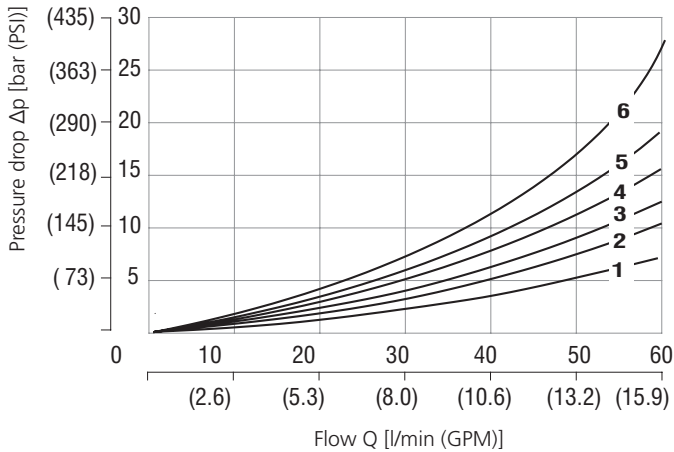

Spool symbol	P-A	P-B	A-T	B-T	P-T
Z11,Z21,R11,R21, X11,R32,X32	2	2	3	3	
C11	5	5	5	6	3
H11	2	2	2	3	3
A51	2	2			
Y11,Y51	2	2	2	2	
Y41, Z51,H51	3	3	3	3	
R30	5	4	4	5	
C51	2			3	4
Z71	3	3			
Z81			3	3	
Z91	3			3	3
R31	2			3	
Y91		3	3		

Ordering Code

RPEL2-06 / -

4/2 and 4/3 directional control valve, solenoid operated, Lightline

Valve size

Number of valve positions
two positions **2**
three positions **3**

Spool symbols
see the table "Spool Symbols"

Rated supply voltage of solenoids (at the coil terminal)

12 V DC / 2.45 A	01200
14 V DC / 1.70 A	01400
24 V DC / 1.15 A	02400
27 V DC / 0.89 A	02700
48 V DC / 0.55 A	04800
230 V AC / 0.12 A / 50 (60) Hz	23050

No designation

Surface treatment

A zinc-coated (ZnCr-3), ISO 9227 (240 h)
B zinc-coated (ZnNi), ISO 9227 (520 h)

No designation
V

Seals
NBR
FPM (Viton)

No designation
M2

Manual override
standard
rubber boot protected

Connector
EN 175301-803-A
E1 with quenching diode
E3 with quenching diode
AMP Junior Timer - radial direction
E3A with quenching diode
AMP Junior Timer - axial direction (2 pins; male)
E3A with quenching diode
EN 175301-803-A with integrated rectifier
loose conductors (two insulated wires)
E8 with quenching diode
E8 with quenching diode
Deutsch DT04-2P - axial direction (2 pins; male)
E12A with quenching diode

- For directional valves with two solenoids, one solenoid must be de-energized before the other solenoid can be charged.
- For AC voltage supply use coils with connector type E5.
- For other solenoid voltage supply options see data sheet C_8007.
- The solenoid operated valves are delivered without connectors. For available connectors see data sheet K_8008.
- The orifice to the P port can be ordered separately, see data sheet SP_8010.
- Mounting bolts M5 x 45 DIN 912-10.9 or studs must be ordered separately. Tightening torque is 8.9 Nm (6.56 lbf.ft).
- Besides the commonly used valve versions shown other special models are available. Contact our technical support for their identification, feasibility and operating limits.

Spool Symbols

Type	Symbol	Interposition	Type	Symbol	Interposition	Type	Symbol	Interposition
Z11			R11			Y82		
C11			R21			Z11		
H11			R32			C11		
Y11			A51			H11		
Y41			C51			Y11		
Y51			H51			Y41		
Z51			Z81			X11		
Z71			Z91			R21		

Solenoid Coil in millimeters (inches)

E1 - EN 175301-803-A E2 - E1 with quenching diode IP65 29 (1.14) 49,4 (1.95) 19 (0.75) 37 (1.46)	E3 - AMP Junior Timer - radial direction E4 - E3 with quenching diode IP67 42 (1.65) 49,4 (1.95) 19 (0.75) 37 (1.46)	E3A - AMP Junior Timer - axil direction E4A - E3A with quenching diode IP67 38,1 (1.50) 49,4 (1.95) 19 (0.75) 37 (1.46)	E5 - Connector EN 175301-803-A + integrated rectifier IP65 35 (1.38) 49,4 (1.95) 19 (0.75) 37 (1.46) 50,6 (1.99)
E8 - Loose conductors (two insulated wires) E9 - (E8 with quenching diode) IP65 A 31 (1.220) 49,4 (1.945) 19 (0.748) 37 (1.457) Note: A = Standard 300 mm (11.8 inch), other lengths on demand	E12A - Deutsch DT04-2P - axil direction E13A - E12A with quenching diode IP67 / IP69 42,5 (1.67) 49,4 (1.95) 19 (0.75) 37 (1.46)		

The indicated IP protection level is only achieved if the connector is properly mounted.

Manual Override in millimeters (inches)

No designation - standard 65,5 (2.58)	Designation M2 - rubber boot protected 78 (3.07)
---	--

In case of solenoid malfunction or power failure, the spool of the valve can be shifted by manual override as long as the pressure in port T does not exceed 25 bar (363 PSI). For alternative manual overrides contact our technical support.

RPEL2-063x/xE1*

Valve with two solenoids

Spool symbols

Z11, C11, H11, Y11, H11, Y41

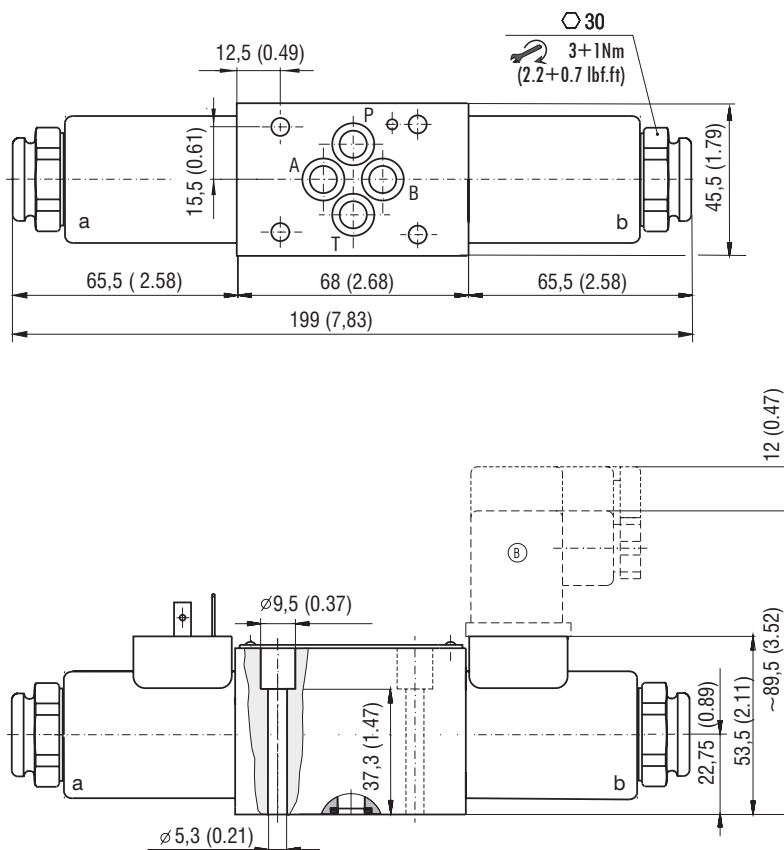

RPEL2-062x/xE1*

Valve with one solenoid „a“

Spool symbols

Z51, Y51, C51, H51, Y82, X11, X21, X32

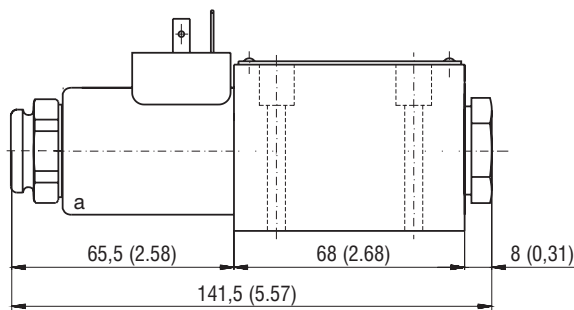

RPEL2-062x/xE1*

Valve with one solenoid „b“

Spool symbols

Z11, Y11, C11, H11, Y41, R11, R21, R32, A51, Z71, Z81, Z91

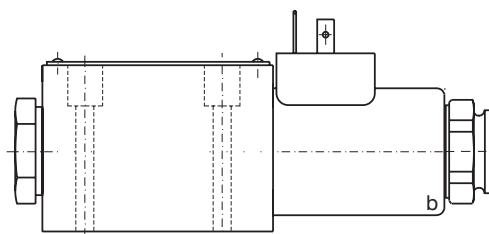

Mounting screws 8.9 Nm (7 lbf.ft)
M5x45 DIN 912-10.9

4/2 and 4/3 Directional Control Valve, Solenoid Operated

RPE3-06

Size 06 (D03) • Q_{max} 80 l/min (21 GPM) • p_{max} 350 bar (5100 PSI)

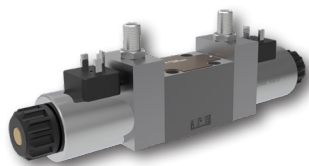

Technical Features

- › Direct acting, directional control valve with subplate mounting interface acc. to ISO 4401, DIN 24340 (CETOP 03)
- › High transmitted hydraulic power up to 350 bar with optimized design to minimize pressure drop
- › Five chamber housing design with reduced hydraulic power dependence on fluid viscosity
- › The valve is available with interchangeable DC solenoids, also for AC power supply using a built-in rectifier bridge
- › Wide range of solenoid electrical terminal versions available
- › Wide range of interchangeable spools and manual overrides available
- › CSA Certificate upon request
- › Inductive contactless Normally Open and Normally Closed spool position sensor option
- › Soft-shift spool speed control option
- › The coil is fastened to the core tube with a retaining nut and can be rotated by 360° to suit the available space
- › In the standard version, the valve housing is phosphated. The steel parts are zinc coated (240 h corrosion protection in NSS acc. to ISO 9227)
- › With optional increased surface corrosion protection of the whole valve 520 h in NSS, e.g. for mobile applications

ISO 4401-03-02-0-05

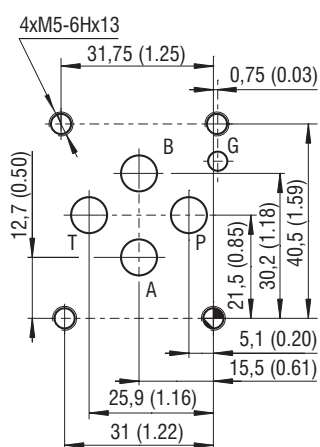

Ports P, A, B, T - max Ø7.5 mm (0.29 in)

Technical Data

Valve size	06 (D03)		
Max. flow	80 (21.1)		
Max. operating pressure at ports P, A, B	bar (PSI)	standard 350 (5080)	
		320 (4640) acc. to CSA	
Max. operating pressure at port T	bar (PSI)	210 (3050)	
Fluid temperature range (NBR)	°C (°F)	-30 ... +80 (-22 ... +176)	
Fluid temperature range (FPM)	°C (°F)	-20 ... +80 (-4 ... +176)	
Ambient temperature range	°C (°F)	-30 ... +50 (-22 ... +122)	
Supply voltage tolerance	%	AC: ±10	DC: ±10
Max. switching frequency	1/h	15 000	
Switching time at v=32 mm/s (156 SUS)	ON	ms	AC: 30 ... 40
	OFF	ms	DC: 30 ... 50
Weight	- valve with 1 solenoid	kg (lbs)	1.6 (3.52)
	- valve with 2 solenoids		2.2(4.85)
General information		Datasheet	Type
		GI_0060	Products and operating conditions
Coil types / connectors		C_8007 / K_8008	C22B* / K*
Mounting interface		SMT_0019	Size 06
Spare parts		SP_8010	

Characteristics measured at v = 32 mm²/s (156 SUS)

Operating limits

Operating limits for maximum hydraulic power at rated temperature and supply voltage equal to 90 % nominal.

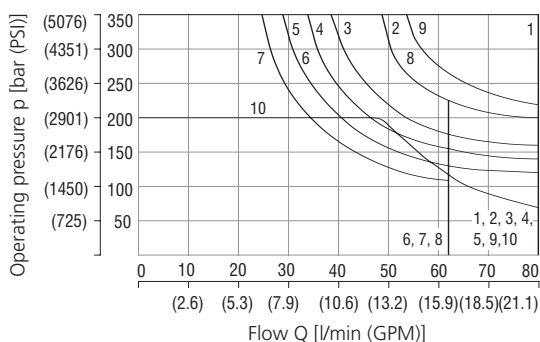

Spool symbol	5	F11	7	Z91
1	Z11			
6	C11	R11	5	R31
5	H11	R21	5	H51
1	P11	A51	7	F51
2	Y11	P51	3	X11
5	L21	Y51	7	K11
8	B11	C51	7	N11
6	Y41	Z51	10	X25
1	Z21	Z71	1	J15
5	C41	Z81	9	J75

Pressure drop related to flow rate

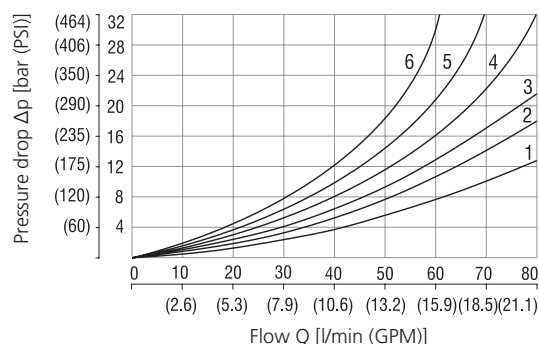

Spool symbol	P-A	P-B	A-T	B-T	P-T
Z11,L21,B11,R11	2	2	3	3	
R21,X11,N11,J15					
C11	5	5	5	6	3
H11	2	2	2	3	3
P11	1	1	3	3	
Y11	2	2	2	2	
Y41	3	3	3	3	
Z21,Z51,H51		2	3		
C41	4	4			5
F11	1	2		3	3
A51,J75	2	2			

For operating limits under conditions and flow directions other than shown contact our technical support. Admissible operating limits may be considerably lower with only one direction of flow (A or B plugged, or without flow.)

Ordering Code

RPE3 - 06

4/2 and 4/3 directional control valve, solenoid operated

Valve size

Number of spool positions





two positions 2
three positions 3

Spool symbols

see the table "Spool Symbols"

Rated supply voltage of solenoids

(at the coil terminals)

12 V DC / 2.72 A  **01200**
 24 V DC / 1.29 A  **02400**
 27 V DC / 1.07 A **02700**
 205 V DC / 0.15 A **20500**
 24 V AC / 1.56 A / 50 (60 Hz) **02450**
 120 V AC / 0.26 A / 60 Hz  **12060**
 230 V AC / 0.15 A / 50 (60) Hz  **23050**

 CSA upon request - only for 320 bar (4640 PSI)

Connector

EN 175301-803-A
 E1 with quenching diode
 AMP Junior Timer - axial direction (2 pins; male)
 E3A with quenching diode
 EN 175301-803-A with integrated rectifier
 Loose conductors (two insulated wires)
 E8 with quenching diode
 Deutsch DT04-2P - axial direction (2 pins; male)
 E12A with quenching diode

 **E1**
 **E2**
E3A
 **E4A**
 **E5**
 **E8**
E9
E12A
E13A

No designation
U

CSA Certified
 standard
 CSA marking

No designation

A zinc-coated (ZnCr-3), ISO 9227 (240 h)
B zinc-coated (ZnNi), ISO 9227 (520 h)

Surface treatment

standard

No designation

S1
S4

Spool monitoring

without sensors
 normally-open sensor
 normally-closed sensor

No designation

V

Seals

NBR
 FPM (Viton)

No designation

T1

Soft-shift spool speed control

without soft-shift control
 orifice Ø 0.7 mm (0.03 inch) in solenoid

No designation

N1
N2
N3
N4
N5
N7
N8
N9

Manual override

standard
 cap nut covered
 rubber boot protected
 detent assembly with the ball
 hand screw
 socket head screw, size 3
 detent assembly with the nut
 with ball
 without manual override

- For directional valves with two solenoids, one solenoid must be de-energized before the other solenoid can be charged.
- For AC voltage supply use coils with connector type E5.

- For other solenoid voltage supply options see data sheet C_8007.
- The solenoid operated valves are delivered without connectors. For available connectors see data sheet K_8008.
- The orifice to the P port can be ordered separately, see data sheet SP_8010.
- Mounting bolts M5 x 45 DIN 912-10.9 or studs must be ordered separately. Tightening torque is 8.9 Nm (6.56 lbf.ft).
- Besides the commonly used valve versions shown other special models are available. Contact our technical support for their identification, feasibility and operating limits.

Spool Symbols

Type	Symbol	Interposition	Type	Symbol	Interposition	Type	Symbol	Interposition
Z11			R11			Z11		
C11			R21			X11		
H11			A51			C11		
P11			P51			H11		
Y11			Y51			K11		
L21			C51			N11		
B11			Z51			F11		
Y41			Z71			X25		
Z21			Z81			J15		
C41			Z91			J75		
F11			R31					
			H51					
			F51					

Typ konektoru cívky elektromagnetu rozměry v milimetrech (in) / Stupeň ochrany

E1, E2 / IP65	E3A, E4A / IP67	E5 / IP65	E8, E9 / IP65	E12A, E13A / IP67 / 69K

The indicated IP protection level is only achieved if the connector is properly mounted.

Manual Override in millimeters (inches)

No designation - standard	N1 - cap nut covered	N2 - rubber boot protected	N3 - detent assembly with the ball	N4 - hand screw
N5 - socket head screw, size 3	N7 - detent assembly with the nut	N8 - with ball	N9 - without manual override	In case of solenoid malfunction or power failure, the spool of the valve can be shifted by manual override as long as the pressure in port T does not exceed 25 bar (363 PSI). For alternative manual overrides contact our technical support.

Spool Position Sensor

S1 - Circuit diagram for the normally - OPEN sensor

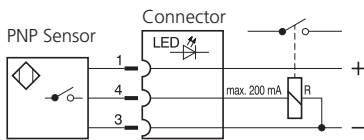

S4 - Circuit diagram of the normally - CLOSED sensor

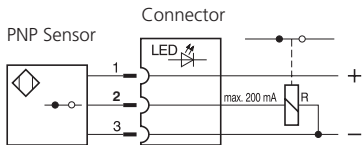

Function of the position sensor:

In the basic position (when the solenoid is switched off), a steel core, connected to the spool, is under the position sensor. The sensor is activated, it means contacts of the sensor S1 are closed and contacts of the sensor S4 are open. After switching on the solenoid the spool with core moves out of the sensor range and the sensor is deactivated.

Technical Data of the Sensor		S1, S4
Rated power supply voltage	V	24 DC
Power supply voltage range	V	10 ... 30 DC
Rated current	mA	200
Sensor enclosure protection (EN 60529)		IP 67
Max. operating pressure at port T	bar (PSI)	210 (3046)
Switching frequency	Hz	1000
Ambient temperature range	°C (°F)	-25 ... +80 (-13 ... +176)
Technical Data of the Connector		
Power supply voltage range	V	10 ... 30 DC
Ambient temperature range	°C (°F)	-25 ... +80 (-13 ... +176)
Indicator		yellow LED

Typical configurations of the valve with a sensor:

3-position valve with two solenoids, equipped with two sensors
 2-position valve with one solenoid, equipped with one sensor on the solenoid side
 2-position valve with a detent assembly of spool, equipped with one sensor on the side of the solenoid which moves the spool from the basic position to the switched position according to the spool symbol
Note: the sensor always indicates the change of spool position realised by the energised solenoid, mounted on the side of the sensor.

Signal of solenoid ① a(b)	Two-Position Directional Control Valve		LED	
	③ Sa(Sb)	S4	S1	S4
0	1	0	ON	OFF
1	0	1	OFF	ON

Signal of solenoid ① a(b)	Three-Position Directional Control Valve				LED					
	③ Sa(Sb)		S4		S1		S4			
	a	b	Sa	Sb	Sa	Sb	Sa - LED	Sb - LED	Sa - LED	Sb - LED
0	0	1	1	0	0	0	ON	ON	OFF	OFF
1	0	0	1	1	0	0	OFF	ON	ON	OFF
0	1	1	0	0	1	1	ON	OFF	OFF	ON

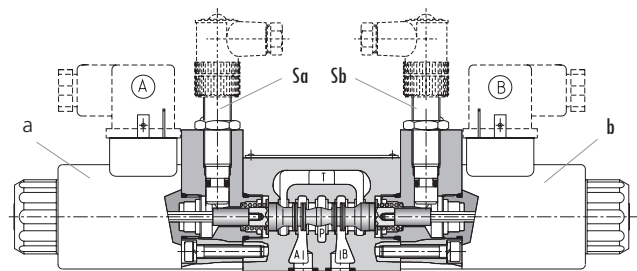
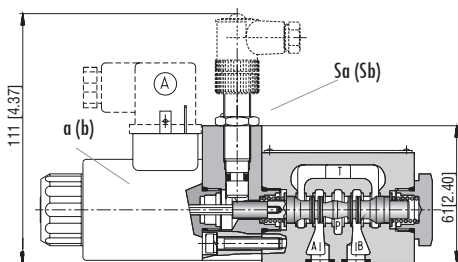

Spool Speed Control in millimeters (inches)

Designation T1	Important:
	<p>This directional valve provides the means to control spool soft shifting by an orifice situated in the solenoid armature. To ensure the proper function of the valve, unobstructed venting of the solenoid is required through the bleeding plug (1). The plugs are accessible after removing the rubber boot (2) from the solenoid cap nut (3).</p>
<p>Switching time ON and OFF</p>	<p>300 ... 800 ms</p>
<p>The switching times shown are valid for viscosity $\nu = 32 \text{ mm}^2/\text{s}$ (156 SUS) and nominal voltage. They depend on working pressure and flow rate of the directional control valve.</p>	

Dimensions in millimeters (inches)

Valve with two solenoids

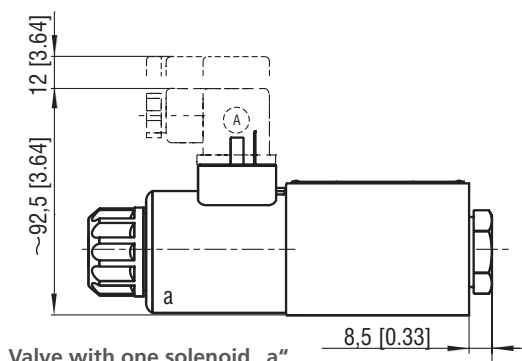
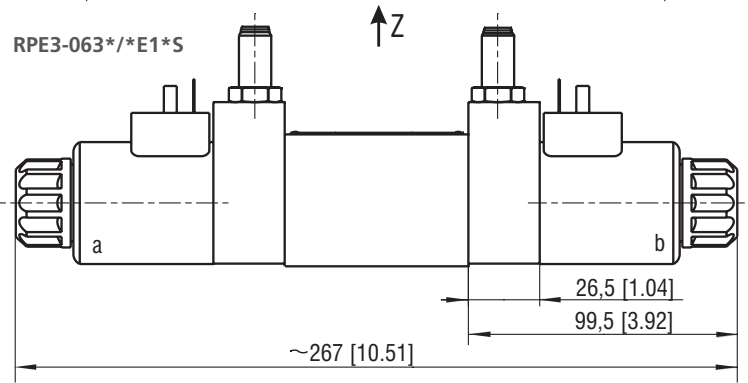
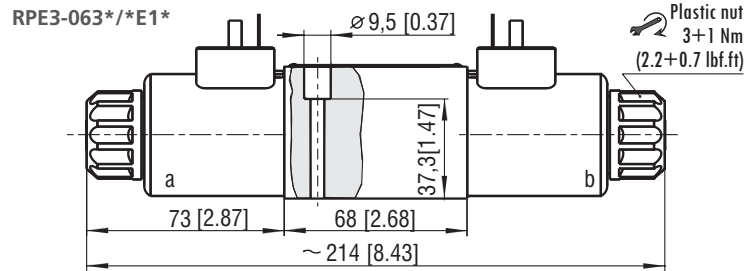
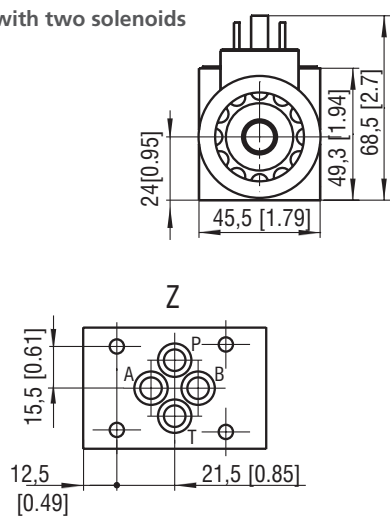

Valve with one solenoid „a“
 Spool symbols R11, R21, A51, P51, Y51, Z51, C51, R31, Z71, Z81, Z91, H51, F51, X25

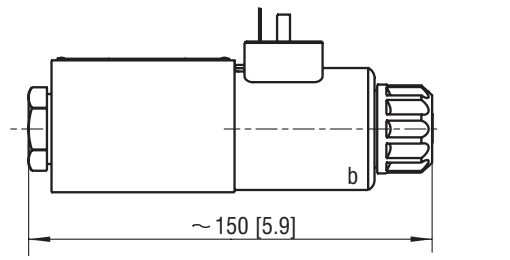
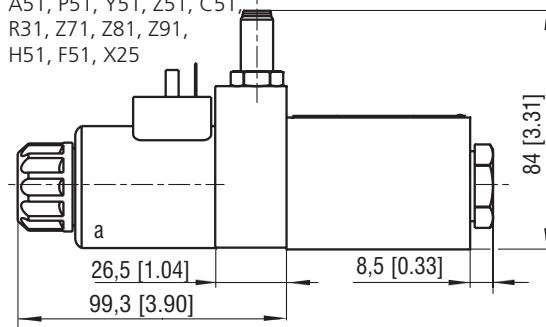

Valve with one solenoid „b“
 Spool symbols X11, Z11, C11, H11, K11, N11, F11

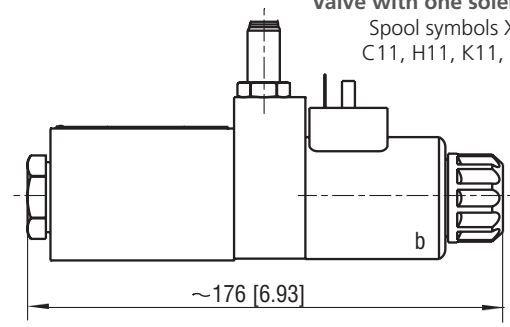

Mounting screws 8.9 Nm (7 lbf.ft)
 M5x45 DIN 912-10.9

Solenoid Operated Directional Control Valve with Auxiliary Lever Override

RPER3-06

Size 06 (D03) • Q_{max} 80 l/min (21 GPM) • p_{max} 350 bar (5100 PSI)

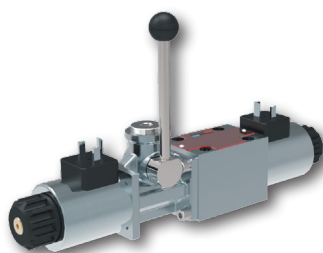

Technical Features

- › Auxiliary lever overrides for ON-OFF solenoid valves of the type RPE3-06 (Datasheet No. 4010) with Size 06 and mounting interface acc. to ISO 4401, DIN 24340 (CETOP 03)
- › Auxiliary lever operators allow the valve to be operated when electrical system is de-energized, e.g. emergency operation, electrical failures, maintenance activities
- › Manual lever and actuation element can be rotated in 90° increments for flexible installation
- › When the valve is electrically operated the hand lever remains stopped in its neutral position
- › The lever override does not affect the performances of the base valve
- › In the standard version, the valve housings are phosphated and the steel parts are zinc-coated for 240 h salt spray protection acc. to ISO 9227
- › Enhanced surface protection for mobile sector available (ISO 9227, 520 h salt spray)

Technical Data

ISO 4401-03-02-0-05

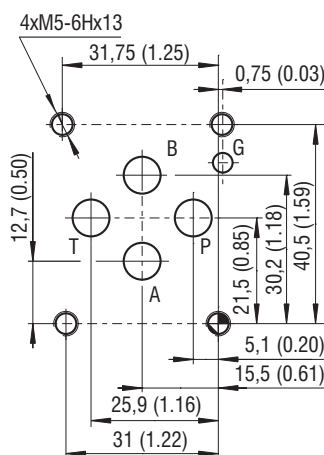

Ports P, A, B, T - max. Ø7.5 mm (0.9 in)

Valve size	06 (D03)	
Max. flow	l/min (GPM)	80 (21.1)
Max. operating pressure at port P, A, B	bar (PSI)	350 (5080)
Max. operating pressure at port T	bar (PSI)	100 (1450)
Fluid temperature range (NBR)	°C (°F)	-30 ... +80 (-22 ... +176)
Fluid temperature range (FPM)	°C (°F)	-20 ... +80 (-4 ... +176)
Ambient temperature range	°C (°F)	-30 ... +50 (-22 ... +122)
Service life	cycles	10 ⁶
Rated power supply voltage	%	AC: ±10 DC: ±10
Max. switching frequency	1/h	10 000
Lever characteristics		
Total stroke angle	deg	±20
Working stroke angle		±12 to 20
Operating force	N (lbf)	40 (29.5)
Lever device weight	kg (lbs)	0.59 (1.3)
General information		
Datasheet	Type	
GI_0060	Products and operating conditions	
Coil types / connectors	C_8007 / K_8008	C22B* / K*
Mounting interface	SMT_0019	Size 06
Spare parts	SP_8010	

Objednací klíč

RPER3-06 [] [] / [] [] [] [] / [] - [] - []

4/2 and 4/3 solenoid operated directional control valve with auxiliary lever override

Valve size

Number of valve positions

two 2
three 3

Spool symbols

see the table "Spool Symbols"

Rated supply voltage of solenoids

(at the coil terminals)

12 V DC / 2,72 A	01200
24 V DC / 1,29 A	02400
27 V DC / 1,07 A	02700
205 V DC / 0,15 A	20500
24 V AC / 1,56 A / 50 (60) Hz	02450
120 V AC / 0,26 A / 60 Hz	12060
230 V AC / 0,15 A / 50 (60) Hz	23050

For directional valves with two solenoids, one solenoid must be de-energized before the other solenoid can be charged.
For AC voltage supply use coils with connector type E5.
For other solenoid voltage supply options see data sheet C_8007.
The solenoid operated valves are delivered without connectors.
For available connectors see data sheet K_8008.
The orifice to the P port can be ordered separately, see data sheet SP_8010.
Mounting bolts M5 x 45 DIN 912-10.9 or studs must be ordered separately
Tightening torque is 8.9+1 Nm (6.56+0.7 lbf.ft)

For operating limits and pressure drop refer to Datasheet No. 4010 of the base valve RPE3-06.

Surface treatment

No designation standard
A zinc-coated (ZnCr-3), ISO 9227 (240 h)
B zinc-coated (ZnNi), ISO 9227 (520 h)

Lever override length
No designation standard 102 mm

Manual lever and position of override actuating section
A19 standard, lever on side A, upward
B19 standard, lever on side B, upward

Seals
No designation NBR
V FPM (Viton)

Manual override at actuator system
No designation standard

Connector

E1 EN 175301-803-A
E2 E1 with quenching diode
E3A AMP Junior Timer - axial direction (2 pins; male)
E4A E3A with quenching diode
E5 EN 175301-803-A with integrated rectifier
E8 loose conductors (two insulated wires)
E9 E8 with quenching diode
E12A Deutsch DT04-2P - axial direction (2 pins; male)
E13A E12A with quenching diode

Besides the commonly used valve versions shown other special models are available.

Contact our technical support for their identification, feasibility and operating limits.

Spool Symbols

Type	Symbol	Interposition	Type	Symbol	Interposition
Z11			R11		
C11			H51		
H11					
Y11					

Dimensions in millimeters (in)

RPER3-063 */ A19

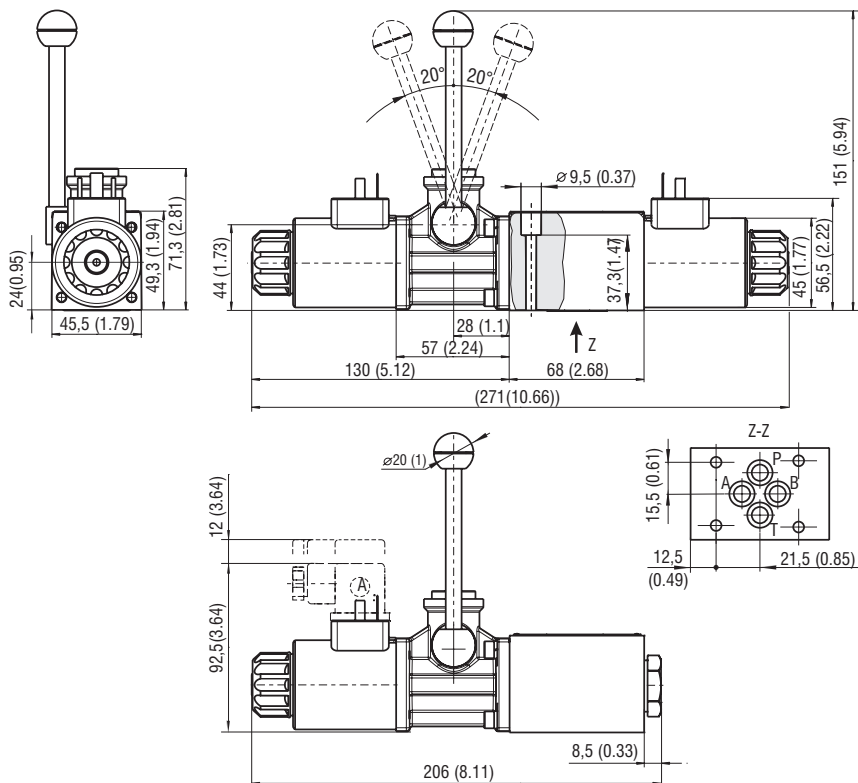

The lever operator should never be used when any solenoid is energized.

RPER3-063 */ B19

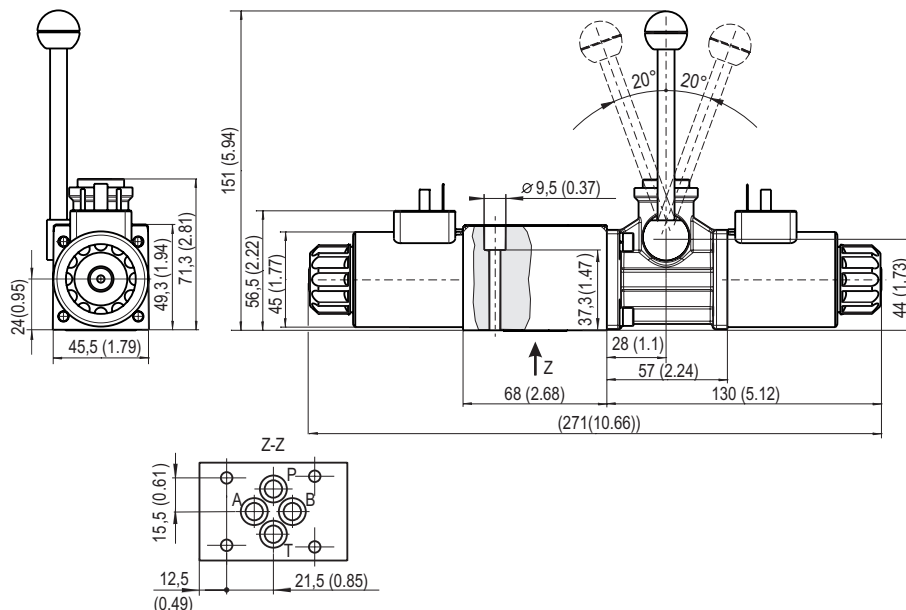

Manual lever and actuating section is shown in the standard supplied position which is the most frequently used. Both elements can be rotated to various positions 90° apart. For other positions of lever and actuating section consult our technical department for their identification.

Mounting screws 8.9+1 Nm (6.56+0.7 lbf.ft)
M5x45 DIN 912-10,9

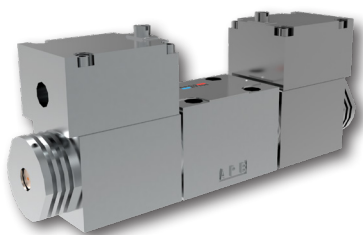
Technical Features

- › Solenoid operated directional control valve, spool type, with subplate mounting surface acc. to ISO 4401, DIN 24340 (CETOP 03) standards
- › Robust design of coil with high resistance to mechanical damage
- › Encapsulation enclosure solenoid version (m)
- › High transmitted hydraulic power
- › Operating pressure up to 350 bar, pressure in T- channel up to 210 bar
- › Low pressure drop achieved by design optimization
- › Five chambers housing design with reduced hydraulic power dependence on fluid viscosity
- › Wide range of interchangeable spools, optional type of manual override
- › Easily interchangeable coil with adjustable connector position by rotating the coil
- › In the standard version, the valve is zinc coated for 520 h protection in NSS acc. to ISO 9227

Functional description

Solenoid operated directional control valves in heavy-duty design have higher protection against mechanical damage, against dust, gas and moisture ingress into the coil. They are intended for operation in heavy working conditions.

Technical Data

ISO 4401-03-02-0-05

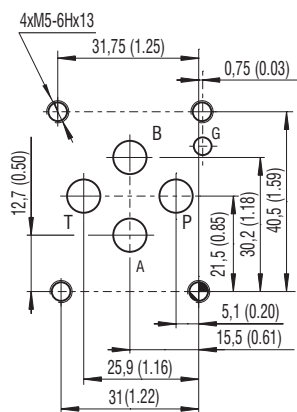
 Ports P, A, B, T - max. \varnothing 7.5 mm (0.29 in)

Valve size	06 (D03)	
Max. flow	l/min (GPM)	60 (15.9)
Max. operating pressure at ports P, A, B	bar (PSI)	350 (5080)
Max. operating pressure at ports T	bar (PSI)	210 (3050)
Pressure drop	bar (PSI)	see Δp -Q characteristics
Fluid temperature range (NBR)	$^{\circ}\text{C}$ ($^{\circ}\text{F}$)	-30 ... +80 (-22 ... +176)
Max. switching frequency	1/h	15 000
Switching time ON at $v=32 \text{ mm}^2/\text{s}$ (156 SUS)	ms	30 ... 50
Switching time OFF at $v=32 \text{ mm}^2/\text{s}$ (156 SUS)	ms	10 ... 50
Weight	valve with 1 solenoid	kg (lbs)
	valve with 2 solenoids	2.52 (5.56)
Technical Data - Heavy-duty Solenoid		
Voltage type		DC
Available voltages	V	24
Available nominal power	W	18
Supply voltage tolerance	%	DC: ± 10
Duty cycle		100 % ED
Enclosure type of the Solenoid to EN 60529		IP 66/68
Ambient temperature range	$^{\circ}\text{C}$ ($^{\circ}\text{F}$)	-30 ... +50 (-22 ... +122)
	Data Sheet	Type
General information	GI_0060	products and operating conditions
Mounting interface	SMT_0019	Size 06
Subplates	Subplates_0002	
Spare parts	SP_8010	
Solenoid Code	Ordering No.	
ET22-46/02400C32-B	42278700	

Danger – safety notice

- › Always disconnect the coil from the power supply before any maintenance, assembly, disassembly or other work on it
- › For directional valves with two solenoids, one solenoid must be without supply voltage charge before the other solenoid can be charged
- › The temperature of the valve – coil surface can exceed 100 $^{\circ}\text{C}$ during the operation. There is a risk of burns
- › Damaged or malfunctioning coils (inclusive cable) must be immediately disconnected from the power supply



Characteristics measured at $v = 32 \text{ mm}^2/\text{s}$ (156 SUS)

Operating limits (p-Q)

Operating limits for maximum hydraulic power at rated temperature and supply voltage equal to 90 % nominal

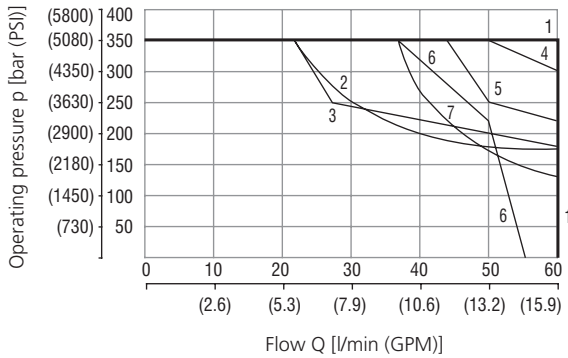

Z11, J15	1
C11	2
H11, X30, B71	3
R11	4
Y11, N11, V41	5
Y51	6
R30	7

Pressure drop related to flow rate (Δp -Q)

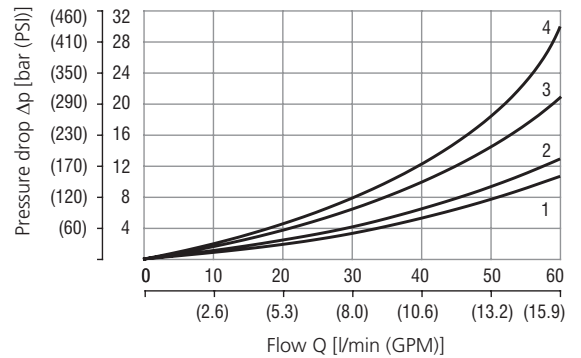

	P→A	P→B	A→T	B→T	P→T
Z11, J15, R11, R30, X30	1	1	2	2	
C11	3	3	3	4	2
H11	1	1	1	2	2
B71	1			1	
Y11	1	1	1	1	
Y51		2	2	2	
N11	1		2	2	
V41		1		2	

Ordering Code

RPET3-06 [] [] / [] [] [] [] - []

- 4/2 and 4/3 directional control valve, solenoid operated, heavy-duty design**
- Valve size**
- Number of spool positions**
two positions: 2
three positions: 3
- Spool symbols**
see the table „Spool Symbols“
- Rated supply voltage of solenoids**
24 V DC / 0.75 A
- 02400**
- Surface treatment**
B: zinc-coated (Zn-Ni), ISO 9227 (520 h)
- Seals**
NBR
- No designation**
- Manual override**
standard (operated by pin)
metal cap nut covered
without manual override
- Solenoid electric connection**
connection box without cable gland
- ET1**
- No designation**
N1
N9

- The valves are delivered without cable glands.
- Mounting bolts M5x45 DIN 912-10.9 or studs must be ordered separately.
- Tightening torque is 8.9+1 Nm (6.56+0.7 lbf.ft).
- The orifice to the P-port can be ordered separately, see data sheet SP_8010.
- Besides the shown types, commonly used valve versions other special models are available. Contact our technical department for their identification, feasibility and operating limits.

Spool Symbols

Type	Symbol	Interposition	Type	Symbol	Interposition	Type	Symbol	Interposition
Z11			Y51			Z11		
C11			R30			B71		
H11			R11			N11		
Y11			X30			V41		
						J15		

Manual Override in millimeters (inches)

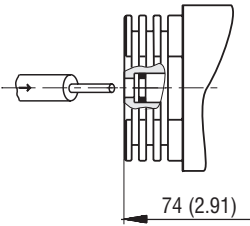
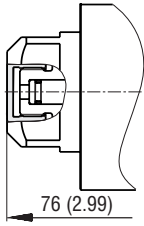
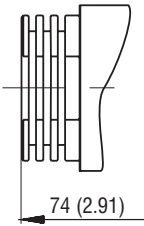
No designation - standard (operated by pin)	Designation N1 - metal cap nut covered	Designation N9 - without manual override
		

Installation

- Ambient operating temperature of the used connecting cable and cable gland shall be at least +105 °C (+221 °F). Use the cable shoe M3 – 0.75 mm² for wire connecting.
- Fastening torque of screws in connecting plate is 0.4 Nm (0.30 lbf.ft). Fastening torque of screws for cover is 4 Nm (2.95 lbf.ft).
- The user shall to ensure free heat emission from the coil surface during operation. The coil must not be activated alone – without connecting to the valve.
- We recommend connecting of the coil to the ground via the purpose-built ground clamp on the coil casing.

Dimensions in millimeters (inches)

RPET3-06**/*ET1-B, RPET3-06**/*ET1N9-B

Valve with one solenoid „a“

Spool symbols
Y51, R30, R11

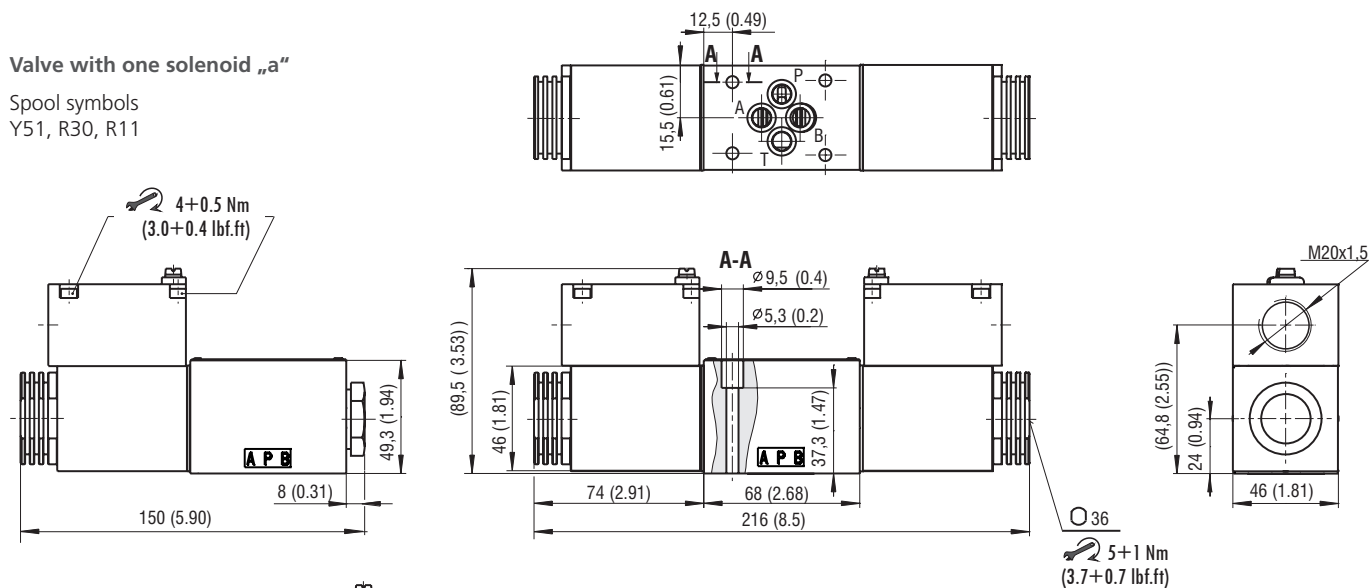

Valve with one solenoid „b“

Spool symbols
X30, Z11, B71, N11, V41

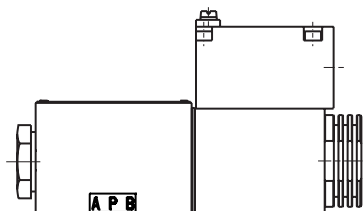

RPET3-06**/*ET1N1-B

Valve with one solenoid „a“

Spool symbols
Y51, R30, R11

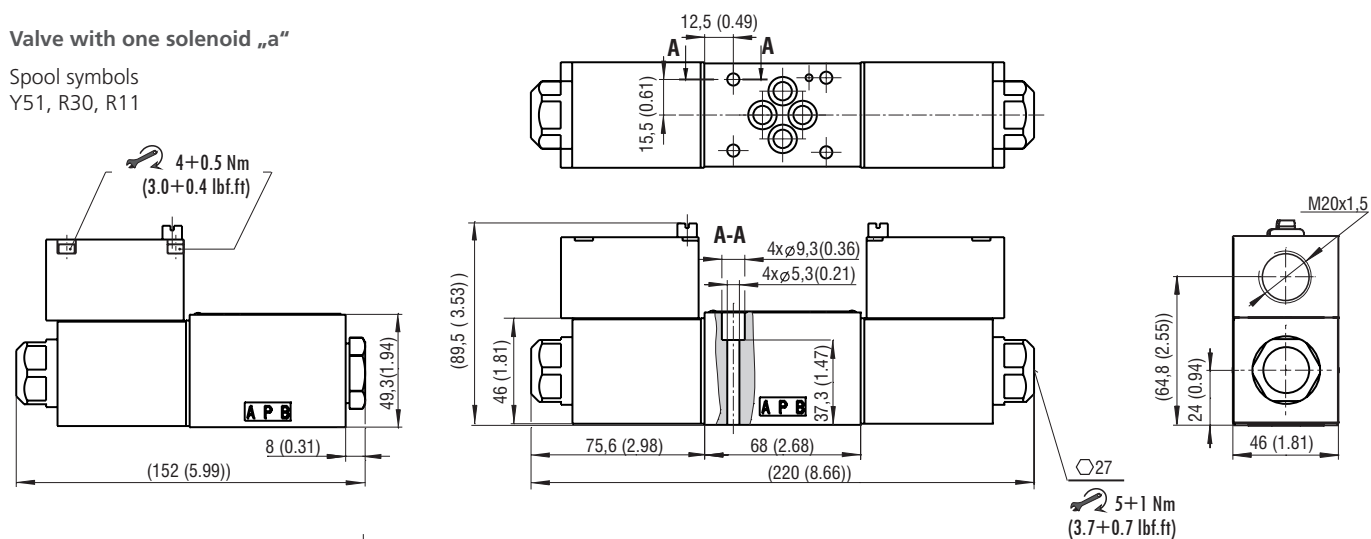

Valve with one solenoid „b“

Spool symbols
X30, Z11, B71, N11, V41

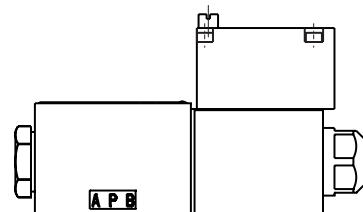

Mounting screws \curvearrowright 8.9+1 Nm (6.56+0.7 lbf.ft)
M5x45 DIN 912-10.9

4/2 and 4/3 Directional Control Valve, Solenoid Operated, Wire Box

RPEW4-06

Size 06 (D03) • Q_{max} 80 l/min (21 GPM) • p_{max} 350 bar (5100 PSI)

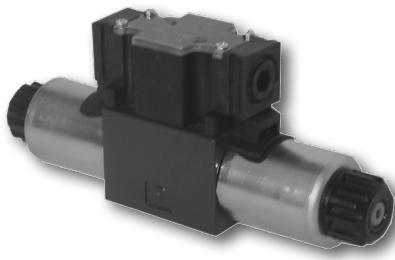

Technical Features

- › Direct acting directional control valve with subplate mounting interface acc. to ISO 4401, DIN 24340 (CETOP 03)
- › High transmitted hydraulic power up to 350 bar with optimized design to minimize pressure drop
- › Five chamber housing design with reduced hydraulic power dependence on fluid viscosity
- › Wire box for solenoid electrical connection with cable gland [1/2" NPT]
- › Optional 3-pin or 5-pin connector acc. to ANSI/B93.55M
- › Type for AC power supply with a rectifier bridge built in the wire box
- › Wide range of interchangeable spools and manual overrides available
- › CSA Certificate upon request
- › Soft-shift spool speed control option
- › Optional shift position indicators (raised arrows) installed on the terminal plate
- › In the standard version, the valve housing is phosphated and steel parts zinc-coated for 240 h salt spray protection acc. to ISO 9227

ISO 4401-03-02-0-05

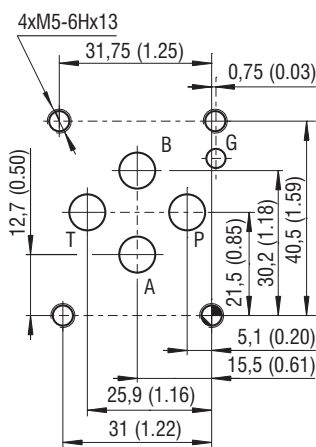

Ports P, A, B, T - max \varnothing 7.5 mm (0.29 in)

Technical Data

Valve size	06 (D03)		
Max. flow	l/min (GPM)	80 (21.1)	
Max. operating pressure at ports P, A, B	bar (PSI)	350 (5080) 320 (4640) for CSA	
Max. operating pressure at port T	bar (PSI)	210 (3050)	
Fluid temperature range (NBR)	°C (°F)	-30 ... +80 (-22 ... +176)	
Fluid temperature range (FPM)	°C (°F)	-20 ... +80 (-4 ... +176)	
Ambient temperature range	°C (°F)	-30 ... +50 (-22 ... +122)	
Supply voltage tolerance	%	AC: \pm 10	DC: \pm 10
Max. switching frequency	1/h	15 000	
Enclosure type acc. to EN 60529	IP 65		
Switching time at $v=32$ mm ² /s (156 SUS)	ON	ms	AC: 30 ... 40 DC: 30 ... 50
	OFF	ms	AC: 30 ... 70 DC: 10 ... 50
Weight	- valve with 1 solenoid	kg (lbs)	1.3 (2.8)
	- valve with 2 solenoids		1.9 (4.2)
	Datasheet	Type	
General information	GI_0060	Products and operating conditions	
Coil types	C_8007	C22B*	
Mounting interface	SMT_0019	Size 06	
Spare parts	SP_8010		

Characteristics measured at $v = 32$ mm²/s (156 SUS)

Operating limits

Operating limits for maximum hydraulic power at rated temperature and supply voltage equal to 90% nominal.

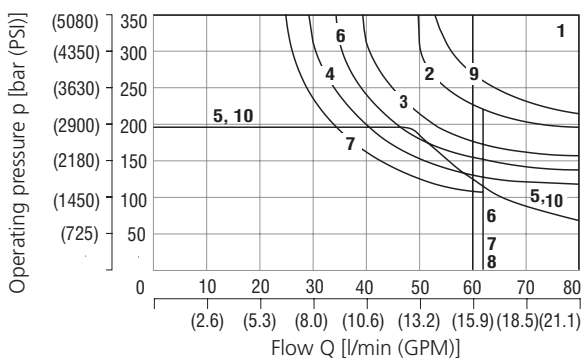

1	Z11	1	Z21	6	C51
6	C11	9	J75	1	Z51
3	H11	5	F11	7	H51
1	P11	3	R11	7	F51
2	Y11	4	R21	3	X11
5	L21	5	A51	7	N11
8	B11	1	P51	10	X25
1	J15	2	Y51		

Pressure drop related to flow rate

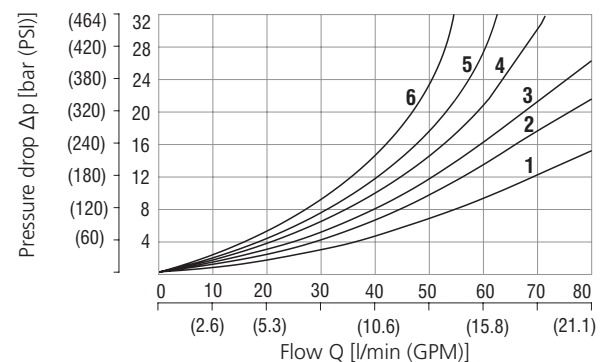

	P-A	P-B	A-T	B-T	P-T		P-A	P-B	A-T	B-T	P-T
Z11,L21,B11,R11 R21,X11,N11,J15	2	2	3	3		P51	1	3			
C11	5	5	5	6	3	Y51	2	2			
H11	2	2	2	3	3	C51	2			3	4
P11	1	1	3	3		C51	2			3	4
A51,J75	2	2				F11	1	2		3	3
Z21,Z51,H51,F51	2	3				Y11	2	2	2	2	

For operating limits under conditions and flow directions other than shown contact our technical support. Admissible operating limits may be considerably lower with only one direction of flow (A or B plugged, or without flow.)

Ordering Code

RPEW4 - 06 / -

4/2 and 4/3 directional control valve, solenoid operated, wire box

Valve size

Number of valve positions

two positions
three positions

2
3

Spool symbols

see the table "Spool symbols"

Rated supply voltage of solenoid

(at the wire box terminal)

12 V DC / 2.72 A

24 V DC / 1.29 A

120 V AC / 0.26 A, 60 Hz*

☉ 01200

☉ 02400

☉ 12060

*DC coils with rectifier in wire box

Connector for wire box and wire box power

DC solenoid for DC power supply

DC solenoid for AC power supply (rectifier in wirebox)

DC solenoid with quenching diode for DC power supply

☉ EW1K

☉ EW1R

☉ EW2K

Wire box version, supply connector

without connector, 1/2 NPT thread at both ends (either side can be used for wiring, remove cover-plug accordingly)

50

50 with LED (B side plugged, A side with feed-through plug)

51

No designation
U

CSA Certified
standard
CSA marking

No designation

Surface treatment
standard

No designation
V

Seals
NBR
FPM (Viton)

No designation
T1

Soft-shift spool speed control
without soft-shift control
orifice \varnothing 0.7 mm (0.03 inch) in solenoid

No designation
N2

Manual override
standard
rubber boot protected

- For directional valves with two solenoids, one solenoid must be de-energized before the other solenoid can be charged.
- The orifice to the P port can be ordered separately, see data sheet SP_8010.
- Mounting bolts M5 x 45 DIN 912-10.9 or studs must be ordered separately. Tightening torque is 8.9+1 Nm (6.56+0.7 lbf.ft).
- Besides the commonly used valve versions shown other special models are available. Contact our technical support for their identification, feasibility and operating limits.

Spool Symbols

Type	Symbol	Interposition	Type	Symbol	Interposition	Type	Symbol	Interposition
Z11			R11			Z11		
C11			R21			X11		
H11			A51			C11		
P11			P51			H11		
Y11			X25			N11		
L21			Y51			F11		
B11			C51			J15		
Z21			Z51			J75		
F11			H51					
			F51					

Solenoid Coil for Wire Box in millimeters (inches)

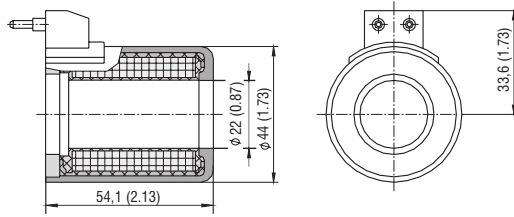

Manual Override in millimeters (inches)

No designation
- standard

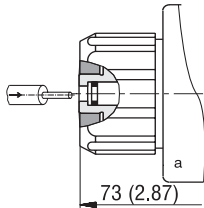

Designation N2
- rubber boot protected

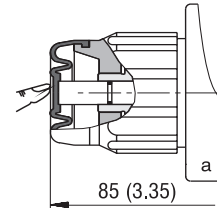

In case of solenoid malfunction or power failure, the spool of the valve can be shifted by manual override as long as the pressure in port T does not exceed 25 bar (363 PSI). For alternative manual overrides contact our technical support.

Spool Speed Control Orifice in millimeters (inches)

Designation T1

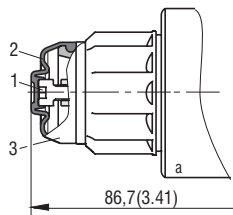

Important:

This directional valve provides the means to control spool soft shifting by an orifice situated in the solenoid armature. To ensure the proper function of the valve, unobstructed venting of the solenoid is required through the bleeding plug (1). The plugs are accessible after removing the rubber boot (2) from the solenoid cap nut (3).

Switching time ON and OFF

300 ... 800 ms

The switching times shown are valid for viscosity $\nu = 32 \text{ mm}^2/\text{s}$ (156 SUS) and nominal voltage. They depend on working pressure and flow rate of the directional control valve.

Example - connecting of connectors ANSI / B93.55M

Pinout - 3-pin connector

- 1 - green
- 2 - black
- 3 - white

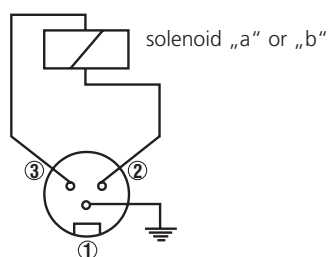
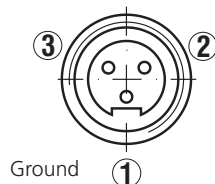

Pinout - 5-pin connector

- 1 - white
- 2 - red
- 3 - green
- 4 - orange
- 5 - black

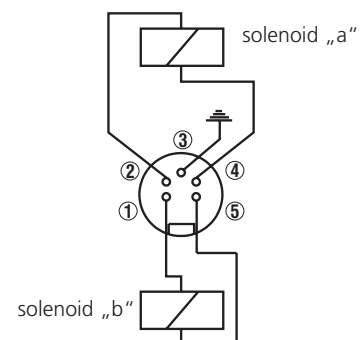
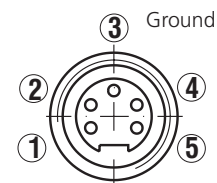

Dimensions in millimeters (inches)

Valve with two solenoids

RPEW4-063*/*EW*

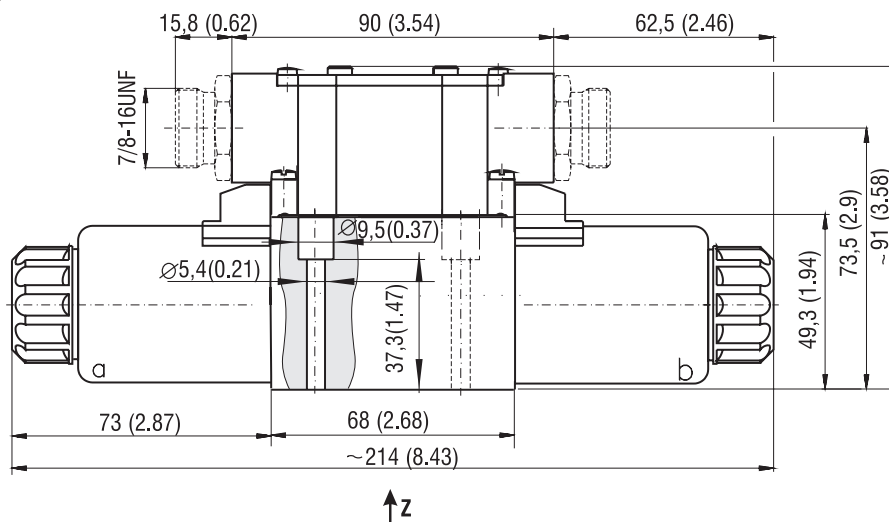

Valve with one solenoid „a”

RPEW4-062*/*EW*

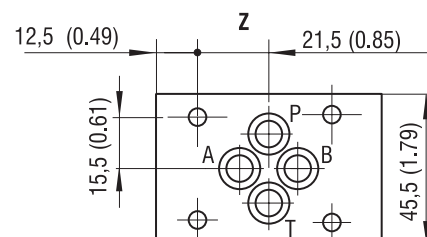
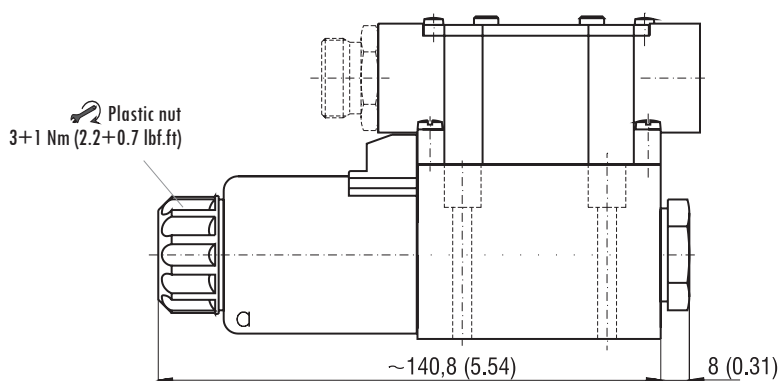

Valve with one solenoid „b”

Spool symbols X11, Z11, C11, H11, N11, F11

RPEW4-062*/*EW*

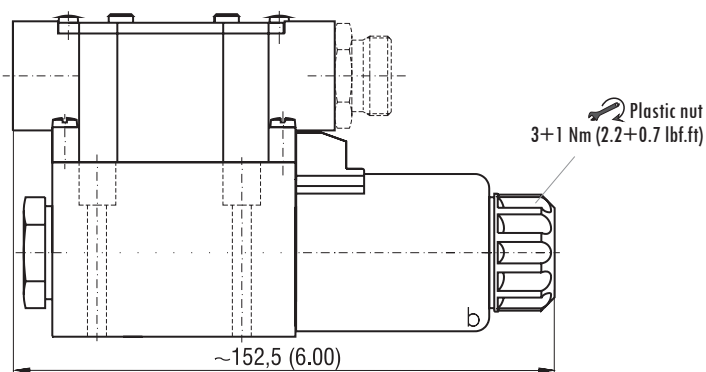

Mounting screws 8.9+1 Nm (6.56+0.7 lbf.ft)
M5 x 45 DIN 912-10.9

4/2 Solenoid operated directional control valve with axial sensor

RPE3-062x/xS3

Size 06 (D03) • Q_{max} 80 l/min (21 GPM) • p_{max} 350 bar (5100 PSI)

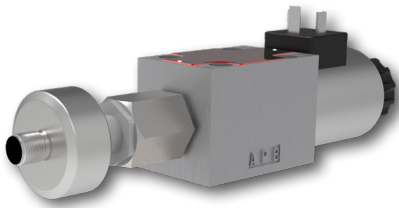

Technical Features

- › Directly solenoid operated spool valve with subplate mounting interface acc. to standards ISO 4401, DIN 24340 (CETOP 03)
- › Contactless inductive spool position sensor with double output signal for safe operation (e.g. of presses or forming machines)
- › High transmitted hydraulic power and low pressure drop
- › Wide range of control voltages and solenoid electrical terminals
- › Various spool types (other possible)
- › Additional damping of the spool moving to prevent pressure surges in the circuit
- › In the standard version the valve body is phosphated. The steel parts are zinc coated (240 h corrosion protection in NSS acc. to ISO 9227).
- › With optional increased surface corrosion protection of the whole valve 520 h in NSS, e.g. for mobile applications

Technical Data

Valve size	06 (D03)		
Max. flow	l/min (GPM)	80 (21.1)	
Max. operating pressure at ports P, A and B	bar (PSI)	350 (5080)	
Max. operating pressure at port T	bar (PSI)	210 (3050)	
Fluid temperature range (NBR)	°C (°F)	-30 ... +80 (-22 ... +176)	
Fluid temperature range (FPM)	°C (°F)	-20 ... +80 (-4 ... +176)	
Ambient temperature range	°C (°F)	-30 ... +50 (-22 ... +122)	
Supply voltage tolerance	%	AC: ±10 DC: ±10	
Max. switching frequency	1/h	15 000	
Switching time at v=32 mm ² /s (156 SUS)	ON	ms	AC: 30 ... 40 DC: 30 ... 50
	OFF	ms	AC: 30 ... 70 DC: 10 ... 50
Weight	kg (lbs)	1.9 (4.2)	

	Datasheet	Type
General information	GI_0060	Products and operating conditions
Coil types / connectors	C_8007 / K_8008	C22B* / K*
Mounting interface	SMT_0019	Size 06
Spare parts	SP_8010	

ISO 4401-03-02-0-05

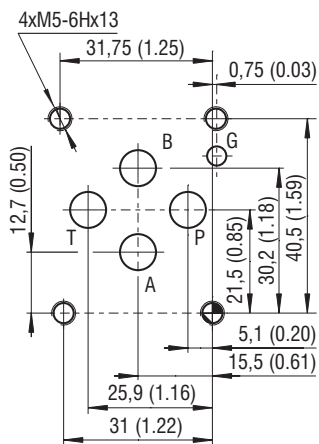

Ports P, A, B, T - max. Ø7,5 mm (0.29 in)

Characteristics measured at v = 32 mm²/s (156 SUS)

Operating limits

Operating limits for maximum hydraulic power at rated temperature and supply voltage equal to 90 % nominal.

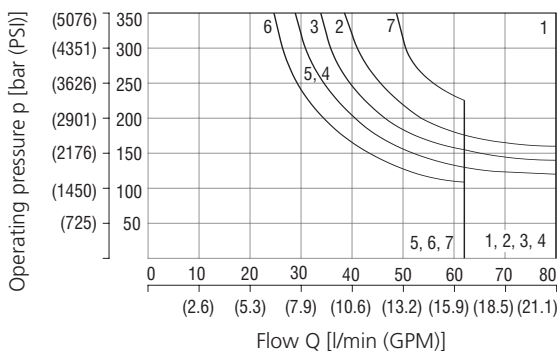

Pressure drop related to flow rate

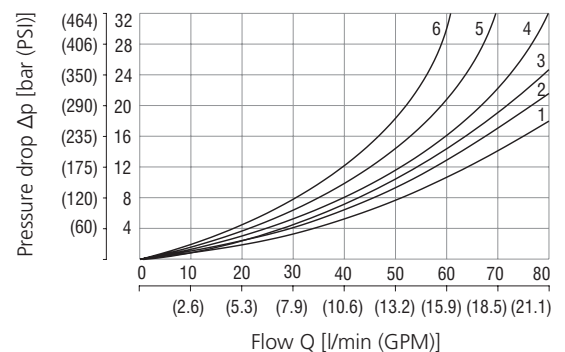

Spool symbol														
Z11	C11	H11	R11	R21	C51	Z51	R31	H51	X11	K11	X32	V51	R30	X30
1	5	4	2	3	5	1	4	4	2	6	3	3	7	7

Spool symbol	P-A	P-B	A-T	B-T	P-T
Z11,R1,R21,X11,X32	1	1	2	2	
C11	5	5	5	6	2
H11	1	1	1	2	2
Z51,H51		1	2		
C51	1			2	4
R31	1			2	
K11		1	2		
R30	3	1	1	2	
X30	1	1	2	3	
V51	3	3			

For operating limits under conditions and flow directions other than shown contact our technical support. Admissible operating limits may be considerably lower with only one direction of flow (A or B plugged, or without flow.)

Ordering Code

RPE3 - 06 2 / / N1 / S3 -

4/2 Solenoid operated directional control valve

Valve size

Number of spool positions
two positions

Spool symbols
see the table "Spool Symbols"

Rated supply voltage of solenoids
(at the coil terminals)

12 V DC / 2.72 A	01200
24 V DC / 1.29 A	02400
27 V DC / 1.07 A	02700
205 V DC / 0.15 A	20500
24 V AC / 1.56 A / 50 (60 Hz)	02450
120 V AC / 0.26 A / 60 Hz	12060
230 V AC / 0.15 A / 50 (60) Hz	23050

- For AC voltage supply use coils with connector type E5.
- For other solenoid voltage supply options see data sheet C_8007.
- The solenoid operated valves are delivered without connectors. For available connectors see data sheet K_8008.
- The orifice to the P port can be ordered separately, see data sheet SP_8010.
- Mounting bolts M5 x 45 DIN 912-10.9 or studs must be ordered separately. Tightening torque is 8.9+1 Nm (7+0.7 lbf.ft).
- Besides the commonly used valve versions shown other special models are available. Contact our technical support for their identification, feasibility and operating limits.

Surface treatment
No designation standard
A zinc-coated (ZnCr-3), ISO 9227 (240 h)
B zinc-coated (ZnNi), ISO 9227 (520 h)

Spool monitoring
axial sensor with two outputs

Seals
No designation NBR
V FPM (Viton)

Soft-shift spool speed control
No designation without soft-shift control

Manual override
cap nut covered

Connector

E1	EN 175301-803-A
E2	E1 with quenching diode
E3A	AMP Junior Timer - axial direction (2 pins; male)
E4A	E3A with quenching diode
E5	EN 175301-803-A with integrated rectifier
E8	Loose conductors (two insulated wires)
E9	E8 with quenching diode
E12A	Deutsch DT04-2P - axial direction (2 pins; male)
E13A	E12A with quenching diode

Spool Symbols

Type	Symbol	Interposition	Type	Symbol	Interposition
R11			X11		
R30*			X30*		
Z51			K11		
R31			Z11		
C51			C11		
H51			H11		
R21			X32		
V51			* Three-chamber design		

Solenoid Coil in millimeters (inches)

E1, E2 Protection degree IP65	E3A, E4A Protection degree IP67	E5 Protection degree IP65	E8, E9 Protection degree IP65	E12A, E13A Protection IP67 / 69K
			Note: A = Standard 300 mm (11.8 in) other lengths on demand	

The indicated IP protection level is only achieved if the connector is properly mounted.

Manual Override in millimeters (inches)

Designation N1
- cap nut covered

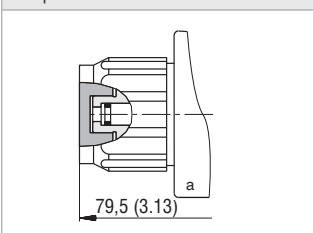

In case of solenoid malfunction or power failure, the spool of the valve can be shifted by manual override as long as the pressure in port T does not exceed 25 bar (363 PSI). For alternative manual overrides contact our technical support.

Spool Position Sensor



4-pin connector with the thread M12

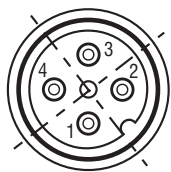

Technical Data		
Max. pressure resistance	bar (PSI)	315 (dynamic)
Operating temperature	°C (°F)	-20 ... +85 (-4 ... +185)
Storage temperature	°C (°F)	-25 ... +85 (-13 ... +185)
Supply voltage U_b	V	24 V DC \pm 20 %
Current consumption (max.)	mA	20
Output voltage (min.)	V	$U_b - 2.5$ V
Output current	mA	2 x 250
Enclosure type (EN 60529)		IP65
Hysteresis of switching point (max.)	mm (in)	0.06 (0.002)
Reproducibility at 25 °C (77 °F)	mm (in)	\pm 0.02 (\pm 0.0008)
Temperature drift	mm / °C	0.002
Weight	kg (lbs)	0.250 (0.55)

Connection scheme of the spool position sensor

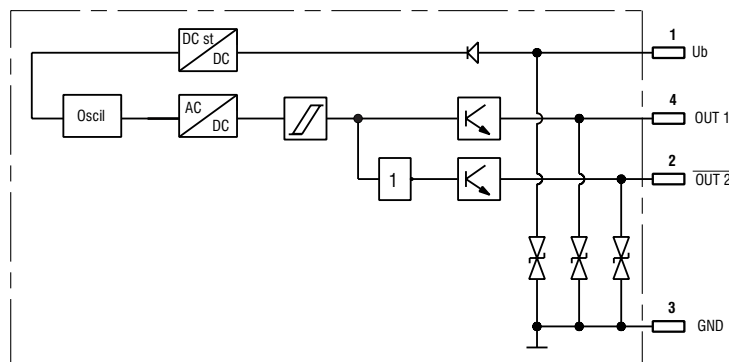

Description of sensor:

Contactless inductive sensor with two transistor switched outputs. The output $\overline{\text{OUT 2}}$ is inverted. The double output signal is protected against mutual interference and increases the reliability of the spool end position signalization, which is important for command system ensuring the safety of such machines as presses, forming machines etc. The switching point can be set within \pm 2 mm by rotating the sensor housing with a coil after loosening the locknut (hexagon 24) and its positioning to the valve body.

Switching diagram of contacts:

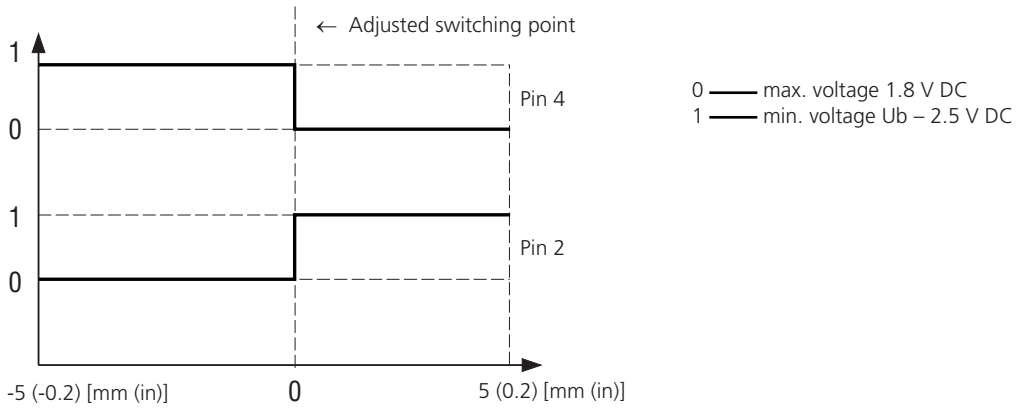

Dimensions in millimeters (inches)

Valve with one solenoid „a”

Spool symbols
R11, Z51, R31...

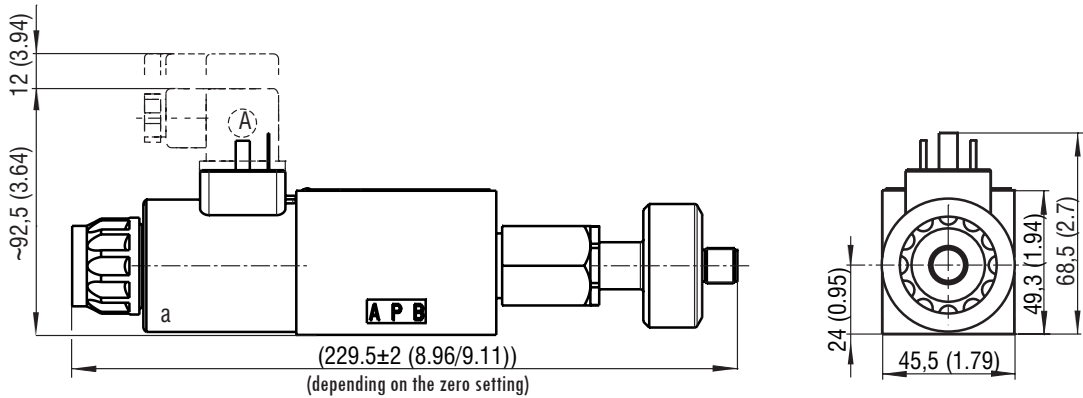

Valve with one solenoid „b”

Spool symbols
X11, K11, Z11...

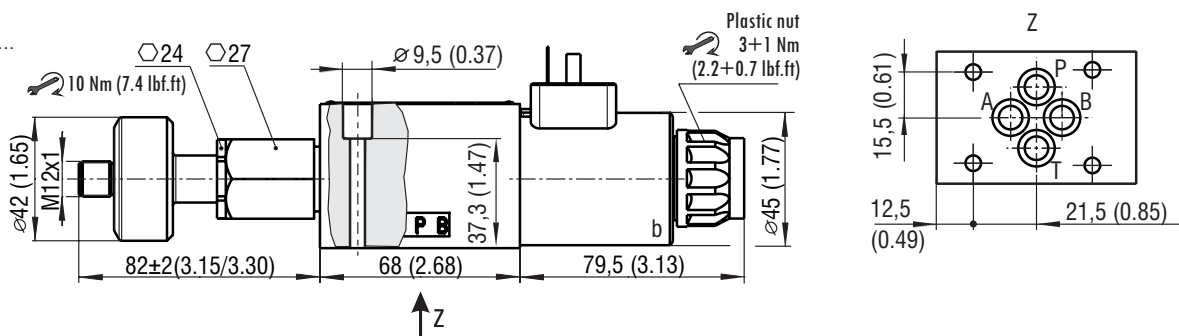

Plastic nut
3+1 Nm
(2.2+0.7 lbf.ft)

Mounting screws $8.9+1$ Nm (7+0.7 lbf.ft)
M5 x 45 DIN 912-10.9

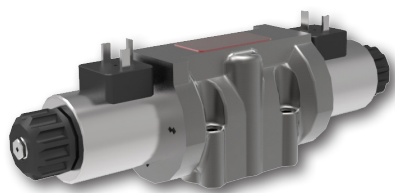

Technical Features

- › Direct acting directional control valve with subplate mounting interface acc. to ISO 4401, DIN 24340 (CETOP 05)
- › Cost-effective Lightline design with reduced solenoid dimensions, suitable for applications with lower required power
- › Three or five chamber design for high transmitted hydraulic power
- › Wide range of solenoid electrical terminas and supply voltage types for electromagnets
- › The coil, fastened to the core tube with a retaining nut, can be rotated by 360° to suit the available space
- › Wide range of interchangeable spools
- › In the standard version the valve body is phosphated. The steel parts are zinc coated (240 h corrosion protection in NSS acc. to ISO 9227
- › With optional increased surface corrosion protection of the whole valve 520 h in NSS, e.g. for mobile applications

ISO 4401-05-04-0-05

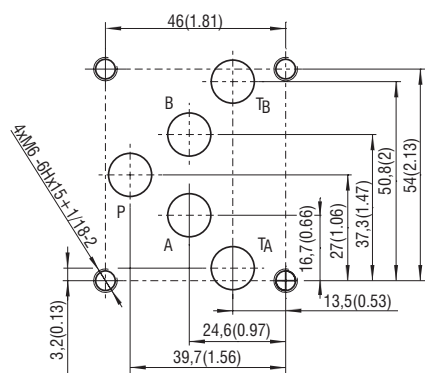

Ports P, A, B, T - max \varnothing 11.2 mm (0.44 in)

Technical Data

Valve size	10 (D05)	
Max. flow	l/min (GPM)	100 (26.4)
Max. operating pressure at ports P, A, B	bar (PSI)	250 (3630)
Max. operating pressure at port T	bar (PSI)	210 (3045)
Fluid temperature range (NBR)	°C (°F)	-30 ... +80 (-22 ... +176)
Fluid temperature range (FPM)	°C (°F)	-20 ... +80 (-4 ... +176)
Ambient temperature range	°C (°F)	-30 ... +50 (-22 ... +122)
Supply voltage tolerance	%	DC: \pm 10
Max. switching frequency	1/h	10 000
Switching time at $v=32$ mm ² /s (156 SUS)	ON	ms
	OFF	ms
Weight	- valve with 1 solenoid	kg (lbs)
	- valve with 2 solenoids	kg (lbs)
		2.9 (6.4)
		3.4 (7.5)
	Datasheet	Type
General information	GI_0060	Products and operating conditions
Coil types / connectors	C_8007 / K_8008	C22B*/K*
Mounting interface	SMT_0019	Size 10
Subplates	Subplates_0002	DP1-10
Spare parts	SP_8010	

Characteristics measured at $v = 32$ mm²/s (156 SUS)

Operating limits (p-Q)

Operating limits for maximum hydraulic power at rated temperature and supply voltage equal to 90% nominal.

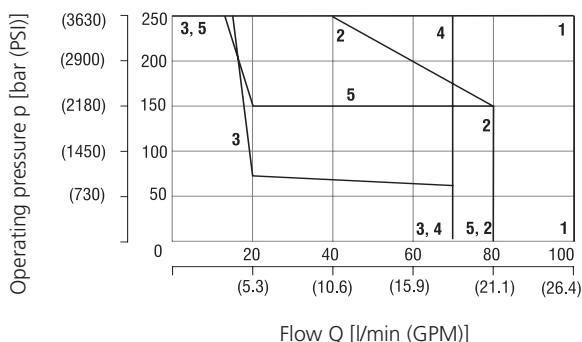

Spool symbol	
1	Z11, Z51
2	Y11 (3k)
1	H11
4	R11, X11 (3k)
3	C11
5	R21 (3k)

Pressure drop related to flow rate (Δp -Q)

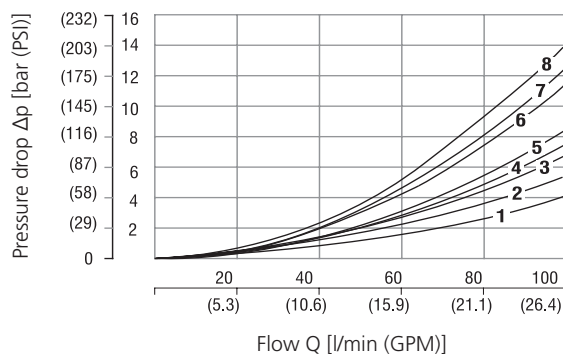

	P-A	P-B	A-T	B-T	P-T
Z11	3	3	3	5	
Z51		3	3		
C11	6	6	7	8	6
H11	1	1	2	4	2
Y11	3	3	2	4	
R11, R21, X11	2	2	4	5	

Directional control valve Dn 10 has double T channel. If only one is directly connected to the tank, the pressure drop in the appliance channel on the closed side A/B →T will be higher by 3 bars.

Ordering Code
RPEL1-10 / -
4/2 and 4/3 directional control valve, solenoid operated, Lightline
Valve size
Number of valve positions

two positions

2

three positions

3
Spool symbols

see the table "Spool Symbols"

Rated supply voltage of solenoids

12 V DC / 2,72 A

01200

14 V DC / 2,14 A

01400

24 V DC / 1,29 A

02400

27 V DC / 1,07 A

02700
No designation
A
B

zinc-coated (ZnCr-3), ISO 9227 (240 h)

zinc-coated (ZnNi), ISO 9227 (520 h)

Surface treatment
standard

No designation
V
Seals

NBR

FPM (Viton)

No designation
N1
Manual override
standard (operated by pin)
cap nut covered

Connector

EN 175301-803-A

E1

E1 with quenching diode

E2
E3A

AMP Junior Timer - axial direction (2 pins; male)

E4A

E3A with quenching diode

E8

loose conductors (two insulated wires)

E9

E8 with quenching diode

E12A

Deutsch DT04-2P - axial direction (2 pins; male)

E13A

E12A with quenching diode

- For directional valves with two solenoids, one solenoid must be de-energized before the other solenoid can be charged.
- For other solenoid voltage supply options see data sheet C_8007.
- The solenoid operated valves are delivered without connectors. For available connectors see data sheet K_8008.
- The orifice to the P port can be ordered separately, see data sheet SP_8010.
- Mounting bolts M6 x 40 DIN 912-10.9 or studs must be ordered separately. Tightening torque is 14⁺¹ Nm (10.3^{+0.7} lbf.ft).
- Besides the shown, commonly used valve versions other special models are available. Contact our technical support for their identification, feasibility and operating limits.

Spool Symbols

Type	Symbol	Interposition	Type	Symbol	Interposition
Z11			R11		
C11			R21		
H11			Z51		
Y11			X11		
P11					
C12					

Solenoid Coil in millimeters (inches)

E1 - EN 175301-803-A E2 - E1 with quenching diode	E3A - AMP Junior Timer - axial direction E4A - E3A with quenching diode	E8 - Loose conductors (two insulated wires) E9 - E8 with quenching diode	E12A - Deutsch DT04-2P - axial direction E13A - E12A with quenching diode
Protection degree IP65	Protection degree IP67	Protection degree IP65	Protection degree IP67 / IP69K
		<p>Note: A = Standard 300 mm (11.81 in), other lengths on demand</p>	

The indicated IP protection level is only achieved if the connector is properly mounted.

Manual Override in millimeters (inches)

No designation - standard (operated by pin)	Designation N1 - cap nut covered

In case of solenoid malfunction or power failure, the spool of the valve can be shifted by manual override as long as the pressure in port T does not exceed 25 bar (363 PSI). For alternative manual overrides contact our technical support.

Valve Dimension in millimeters (inches)

RPEL1-103x/xE1*

Valve with two solenoids

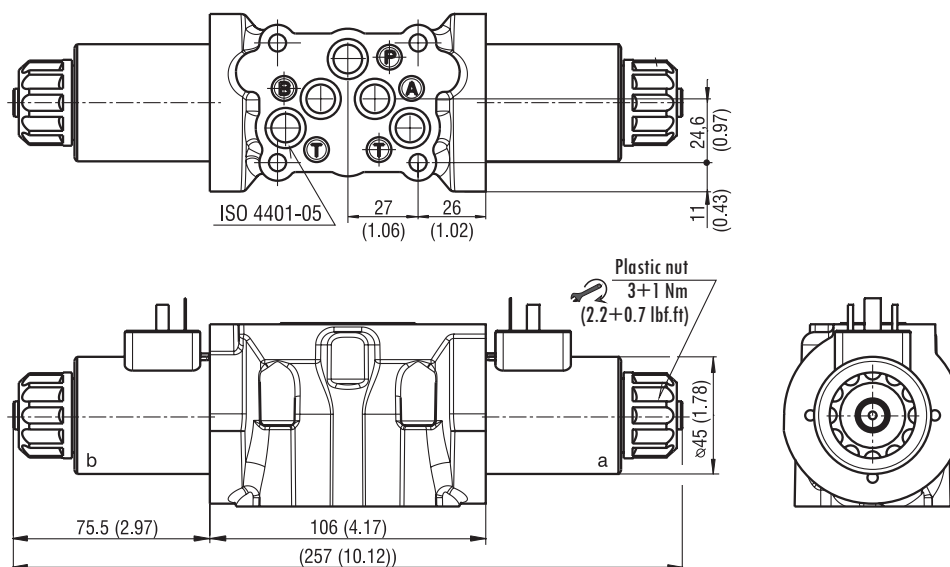

RPEL1-102x/xE1*

Valve with one solenoid

Valve with one solenoid „a”
Spool symbols R11, R21, Z51

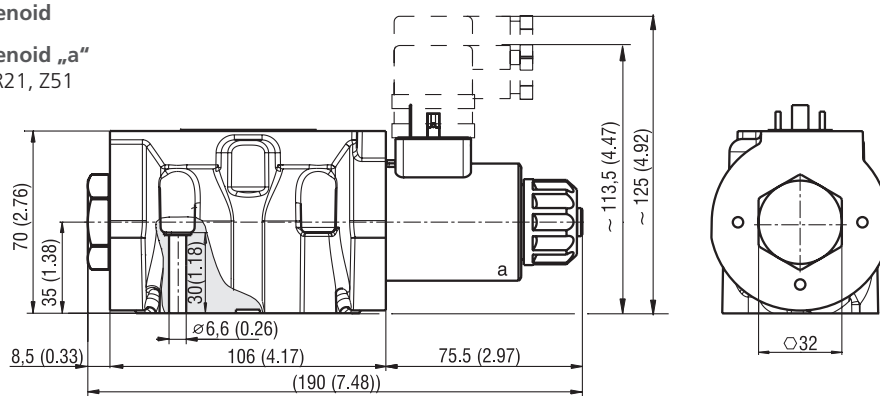

Valve with one solenoid „b”
Spool symbols X11

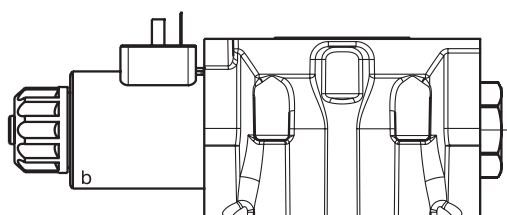

Mounting screws 14⁺¹ Nm (10.3^{+0.7} lbf.ft)
4x M6 x 40 DIN 912-10.9

Ordering Code

RPE4 - 10 [] [] / [] [] [] [] [] [] [] [] [] []

4/2 and 4/3 directional control valve, solenoid operated

Valve size

Number of spool positions
two positions **2**
three positions **3**

Spool symbols
see the table "Spool Symbols"

Rated supply voltage of solenoids
(at the coil terminals)

12 V DC / 3.17 A	01200
24 V DC / 1.73 A	02400
27 V DC / 1.52 A	02700
205 V DC / 0.20 A	20500
120 V AC / 0.38 A / 60 Hz	12060
230 V AC / 0.20 A / 50 (60) Hz	23050

Ⓢ CSA upon request.

Connector

EN 175301-803-A	E1
E1 with quenching diode	E2
AMP Junior Timer - radial direction (2 pins; male)	E3
E3 with quenching diode	E4
EN 175301-803-A with integrated rectifier	E5
Loose conductors (two insulated wires)	E8
E8 with quenching diode	E9
Deutsch DT04-2P - axial direction (2 pins; male)	E12A
E12A with quenching diode	E13A

No designation
U

CSA Certified
standard
CSA marking

Surface treatment
standard
A zinc-coated (ZnCr-3), ISO 9227 (240 h)
B zinc-coated (ZnNi), ISO 9227 (520 h)

Spool monitoring
without sensors
S1 normally-open sensor
S4 normally-closed sensor

Seals
NBR
FPM (Viton)

Soft-shift spool speed control
without soft-shift control
T0 with plugged cavity for optional soft shift installation
T2 orifice Ø0.6 mm (0.02 inch) in T line bridge
T3 adjustable needle valve in T line bridge

Manual override
standard
N1 cap nut covered
N2 rubber boot protected
N4 hand screw
N5 socket head screw
N9 without manual override

- For directional valves with two solenoids, one solenoid must be de-energized before the other solenoid can be charged.
- For AC voltage supply use coils with connector type E5.
- For other solenoid voltage supply options see data sheet C_8007.
- The solenoid operated valves are delivered without connectors. For available connectors see data sheet K_8008.

- The orifice to the P port can be ordered separately, see data sheet SP_8010.
- Mounting bolts M6 x 45 DIN 912-10.9 or studs must be ordered separately. Tightening torque is 14 Nm (10.3 lbf.ft).
- Besides the commonly used valve versions shown other special models are available. Contact our technical support for their identification, feasibility and operating limits. versions are available: consult our technical department for their identification, feasibility and operating limits.

Spool Symbols

Type	Symbol	Interposition	Type	Symbol	Interposition
Z11			P51		
C11			Y51		
H11			C51		
P11			Z51		
Y11			B51		
L21			H51		
B11			X11		
C21			C11		
R11			H11		
R21			J15		
A51			J75		

Type of Solenoid Coil in millimeters (inches)

E1, E2 Protection degree IP65	E3, E4 Protection degree IP65	E5 Protection degree IP65	E8, E9 Protection degree IP65	E12A, E13A Protection IP67 / 69K
The indicated IP protection level is only achieved if the connector is properly mounted.			Note: A = Standard 300 mm (11.81 in), other lengths on demand	

Manual Override in millimeters (inches)

No designation - standard	Designation N1 - cap nut covered	Designation N2 - rubber boot protected	Designation N4 - hand screw	Designation N5 - socket head screw size 3	Designation N9 - without manual override

In case of solenoid malfunction or power failure, the spool of the valve can be shifted by manual override as long as the pressure in port T does not exceed 25 bar (363 PSI). For alternative manual overrides contact our technical support.

Spool Position Sensor

S1 - Circuit diagram of the normally - **OPEN** sensor

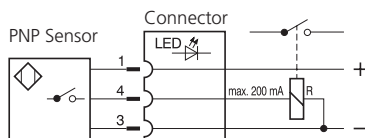

S4 - Circuit diagram of the normally - **CLOSED** sensor

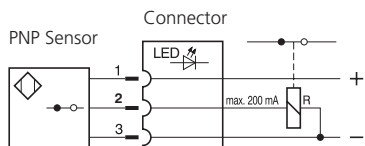

Function of the position sensor:

In the basic position (when the solenoid is switched off), a steel core, connected to the spool, is under the position sensor. The sensor is activated, it means contacts of the sensor S1 are closed and contacts of the sensor S4 are open. After switching on the solenoid the spool with core moves out of the sensor range and the sensor is deactivated.

Technical Data of the Sensor		S1, S4
Rated power supply voltage	V	24 DC
Power supply voltage range	V	10 ... 30 DC
Rated current	mA	200
Sensor enclosure protection (EN 60529)		IP67
Max. operating pressure	bar (PSI)	210 (3046)
Switching frequency	Hz	1000
Ambient temperature range	°C (°F)	-25 ... +80 (-13 ... +176)
Technical Data of the Connector		
Power supply voltage range	V	10 ... 30 DC
Ambient temperature range	°C (°F)	-25 ... +80 (-13 ... +176)
Indicator		yellow LED

Typical configurations of the valve with a sensor:

- 3-position valve with two solenoids, equipped with two sensors
 - 2-position valve with one solenoid, equipped with one sensor on the solenoid side
 - 2-position valve with a detent assembly of spool, equipped with one sensor on the side of the solenoid which moves the spool from the basic position to the switched position according to the spool symbol
- Note:** the sensor always indicates the change of spool position realised by the energised solenoid, mounted on the side of the sensor.

① Signal of solenoid	Two-Position Directional Control Valve			
	① a(b)	③ Sa(Sb)	LED	
③ Signal of sensor	S1	S4	S1	S4
0	1	0	ON	OFF
1	0	1	OFF	ON

① a(b)		Three-Position Directional Control Valve				LED			
		③ Sa(Sb)		S4		S1		S4	
a	b	Sa	Sb	Sa	Sb	Sa - LED	Sb - LED	Sa - LED	Sb - LED
0	0	1	1	0	0	ON	ON	OFF	OFF
1	0	0	1	1	0	OFF	ON	ON	OFF
0	1	1	0	0	1	ON	OFF	OFF	ON

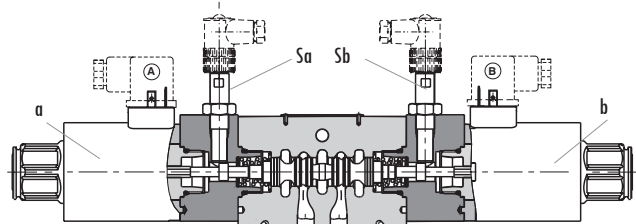
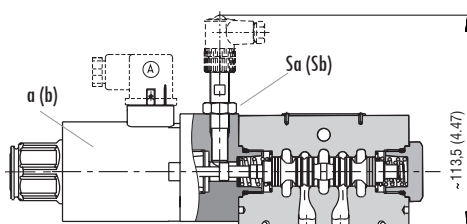

Spool Speed Control in millimeters (inches)

Designation T0 - Plug VSTI M10x1	Designation T2 - Orifice $\varnothing 0.6$ (0.02)	Designation T3 - Needle valve
Plugged cavity for optional soft-shift control devices installation (T2, T3)	Switching time ON and OFF	The orifice extends the valve shifting time.
		The needle valve allows continuous adjustment of the shifting time.
	120 ... 350 ms	30 ... 2000 ms
The switching times shown are valid for viscosity $\nu = 32 \text{ mm}^2/\text{s}$ (156 SUS) and nominal voltage. They depend on working pressure and flow rate of the directional control valve.		

Dimensions in millimeters (inches)

Valve with two solenoids

RPE4-103*/*E1

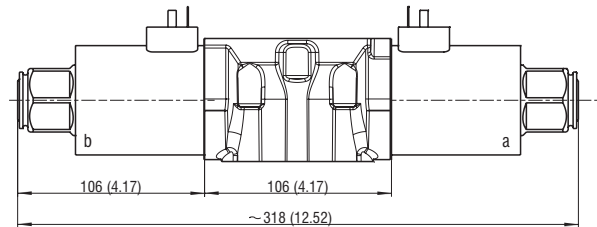
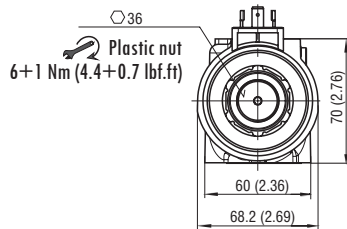

RPE4-103*/*E1*S

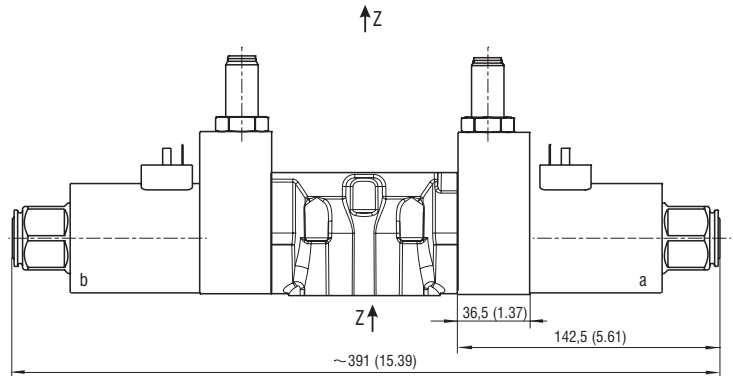
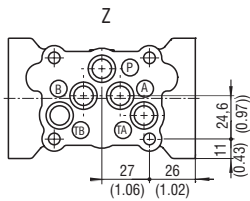

Valve with one solenoid „b“

Spool symbols X11, C11, H11

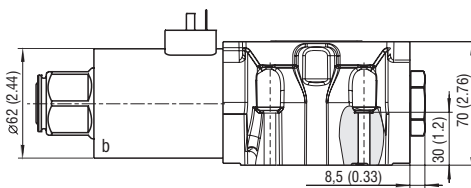

Valve with one solenoid „a“

Spool symbols R11, R21, A51, P51, Y51, C51, B51, Z51, H51

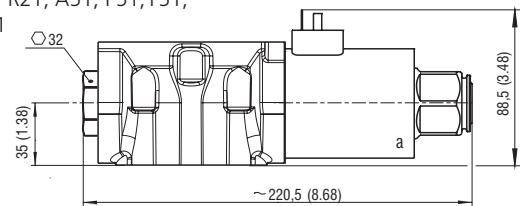

RPE4-102*/*E1*S

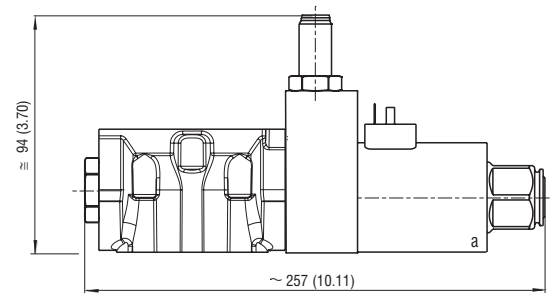
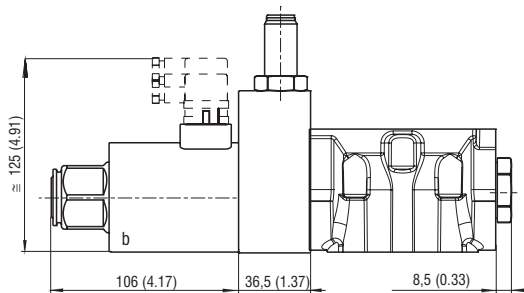

Mounting screws 14 Nm (10.3 lbf.ft)
M6 x 45 DIN 912-10.9

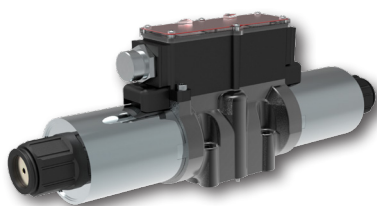

Technical Features

- › Direct acting directional control valve with subplate mounting surface acc. to ISO 4401, DIN 24340 (CETOP 05)
- › High transmitted hydraulic power up to 350 bar with optimized design to minimize pressure drop
- › Five chamber housing design with reduced hydraulic power dependence on fluid viscosity
- › Wire box for solenoid electrical connection with cable gland [1/2" NPT]
- › Optional 3-pin or 5-pin connector acc. to ANSI/B93.55M
- › Type for AC power supply with a rectifier bridge built in the wire box
- › Wide range of interchangeable spools and manual overrides available
- › CSA Certificate upon request
- › Soft-shift spool speed control option
- › Optional shift position indicators (raised arrows) installed on the terminal plate
- › In the standard version, the valve housing is phosphated and steel parts zinc-coated for 240 h salt spray protection acc. to ISO 9227

ISO 4401-05-04-0-05

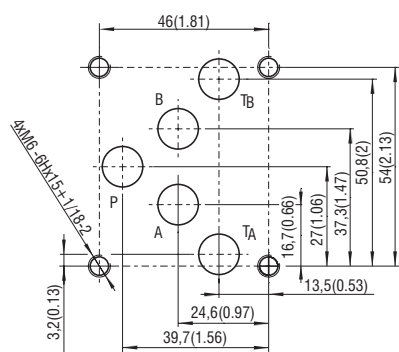

Ports P, A, B, T - max Ø11.2 mm (0.44 in)

Technical Data

Valve size	10 (D05)	
Max. flow	l/min (GPM) 140 (37)	
Max. operating pressure at ports P, A, B	bar (PSI) 350 (5080)	
Max. operating pressure at port T	bar (PSI) 210 (3050)	
Fluid temperature range (NBR)	°C (°F) -30 ... +80 (-22 ... +176)	
Fluid temperature range (FPM)	°C (°F) -20 ... +80 (-4 ... +176)	
Ambient temperature range	°C (°F) -30 ... +50 (-22 ... +122)	
Supply voltage tolerance	% AC: ±10 DC: ±10	
Max. switching frequency	1/h 15 000	
Enclosure type acc. to EN 60529	IP65	
Switching time at v=32 mm ² /s (156 SUS)	ON	ms AC: 50 ... 330 DC: 50 ... 120
	OFF	ms AC: 100 ... 300 DC: 30 ... 90
Weight	- valve with 1 solenoid	kg (lbs) 3.9 (8.6)
	- valve with 2 solenoids	kg (lbs) 5.4 (11.9)
	Datasheet	Type
General information	GI_0060	Products and operating conditions
Coil types	C_8007	C31K*
Mounting interface	SMT_0019	Size 10
Spare parts	SP_8010	

Characteristics measured at v = 32 mm²/s (156 SUS)

Operating limits

Operating limits for maximum hydraulic power at rated temperature and supply voltage equal to 90% nominal.

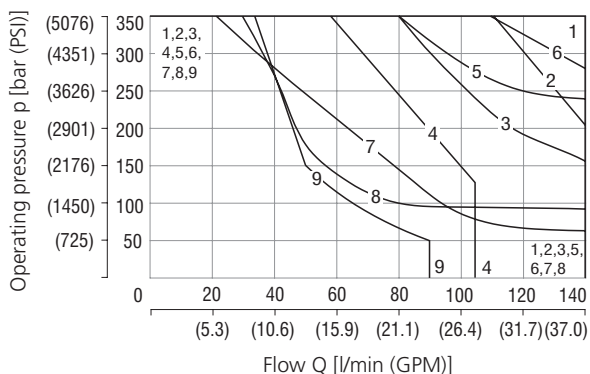

1	Z11	5	Y51	7	L21
1	Z51	3	C11	2	R21
1	H11	3	C51	6	J15
1	H51	2	R11	6	J75
1	P11	2	X11	8	A51
1	P51	4	B11	9	C21
5	Y11	4	B51		

Pressure drop related to flow rate

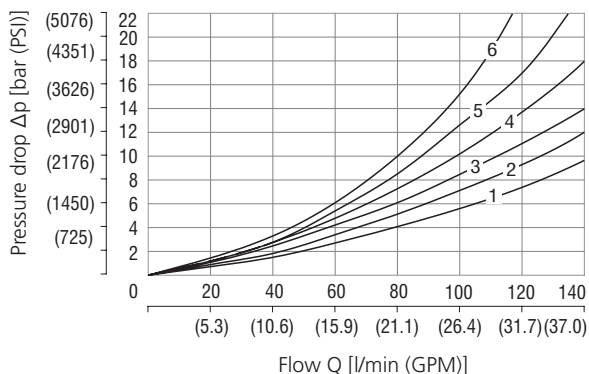

	P-A	P-B	A-T	B-T	P-T		P-A	P-B	A-T	B-T	P-T
Z11,P11,Y11, R11,X11,B11	1	1	2	2		C11	4	3	4	5	1
Z51,P51,Y51, B51		1	2			C21	6	6	6	6	4
R21	1	1	1	3		C51	4			5	1
J15	1	2	2	3		L21	1	1	1	2	2
J75,A51	1	1				H11	1	1	2	2	1
H51		1	2		1						

For operating limits under conditions and flow directions other than shown contact our technical support. Admissible operating limits may be considerably lower with only one direction of flow (A or B plugged, or without flow.)

Ordering Code

RPEW4 - 10 / -

4/2 and 4/3
directional control valve,
solenoid operated, wire box

Valve size

Number of valve positions

two positions **2**
three positions **3**

Spool symbols

see the table "Spool Symbols"

Rated supply voltage of solenoid

(at the wire box terminal)

12 V DC / 3.17 A **01200**

24 V DC / 1.73 A **02400**

120 V AC / 0.38 A, 60 Hz* **12060**

*DC coils with rectifier in wire box

Connector for wire box and wire box power

DC solenoid for DC power supply

DC solenoid for AC power supply (rectifier in wirebox) **EW1K**

Wire box version

without connector, 1/2 NPT thread at both ends (either side
can be used for wiring, remove cover-plug accordingly) **50**

50 with LED (B side plugged, A side with feed-through plug) **51**

CSA Certified
standard
CSA marking
No designation
U

Surface treatment
standard
No designation

Seals
NBR
FPM (Viton)
No designation
V

Soft-shift spool speed control
without soft-shift control
with plugged cavity for optional soft shift installation
orifice \varnothing 0.6 mm (0.02 inch) in T line bridge
adjustable needle valve in T line bridge
No designation
T0
T2
T3

Manual override
standard
rubber boot protected
No designation
N2

- For directional valves with two solenoids, one solenoid must be de-energized before the other solenoid can be charged.
- The port restrictor plugs can be ordered separately from the spare parts data sheet SP_8010.
- Mounting bolts M6 x 45 DIN 912-10.9 or studs must be ordered separately. Tightening torque is 14 Nm (10.3 lbf.ft).
- Besides the shown, commonly used valve versions other special models are available. Contact our technical support for their identification, feasibility and operating limits.

Spool Symbols

Type	Symbol	Interposition	Type	Symbol	Interposition
Z11			P51		
C11			Y51		
H11			C51		
P11			B51		
Y11			Z51		
L21			H51		
B11			X11		
C21			C11		
R11			H11		
R21			J15		
A51			J75		

Solenoid Coil for Wire box in millimeters (inches)

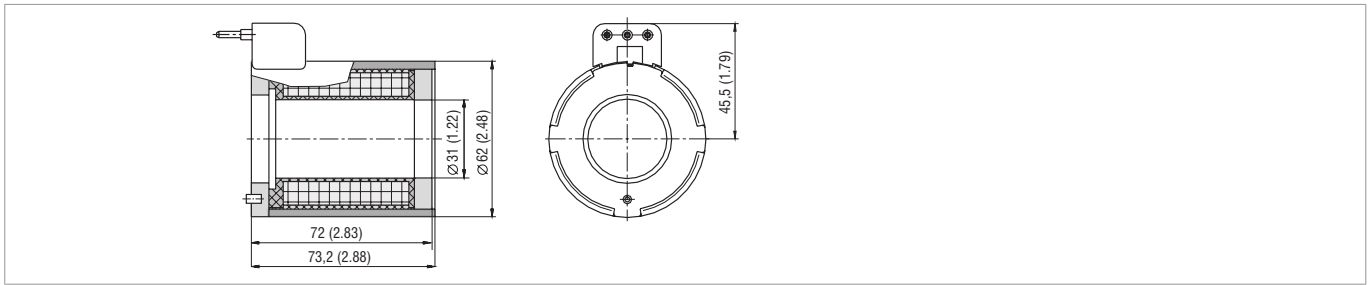

Manual Override in millimeters (inches)

No designation - standard	Designation N2 - rubber boot protected

In case of solenoid malfunction or power failure, the spool of the valve can be shifted by manual override as long as the pressure in port T does not exceed 25 bar (363 PSI). For alternative manual overrides contact our technical support.

Spool Speed Control in millimeters (inches)

Designation T0 - Plug VSTI M10 x 1	Designation T2 - Orifice Ø 0.6 (0.02)	Designation T3 - Needle valve
Plugged cavity for optional soft-shift control devices installation (T2, T3)	Switching time ON and OFF	The orifice extends the valve shifting time.
		The needle valve allows continuous adjustment of the shifting time.
		120 ... 350 ms
		30 ... 2000 ms

The switching times shown are valid for viscosity $\nu = 32 \text{ mm}^2/\text{s}$ (156 SUS) and nominal voltage. They depend on working pressure and flow rate of the directional control valve.

Example - connecting of connectors ANSI / B93.55M

Pinout - 3-pin connector	Pinout - 5-pin connector
<ul style="list-style-type: none"> 1 - green 2 - black 3 - white 	<ul style="list-style-type: none"> 1 - white 2 - red 3 - green 4 - orange 5 - black

Dimensions in millimeters (inches)

Valve with two solenoids

RPEW4-103*/*EW1*

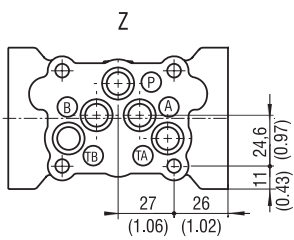
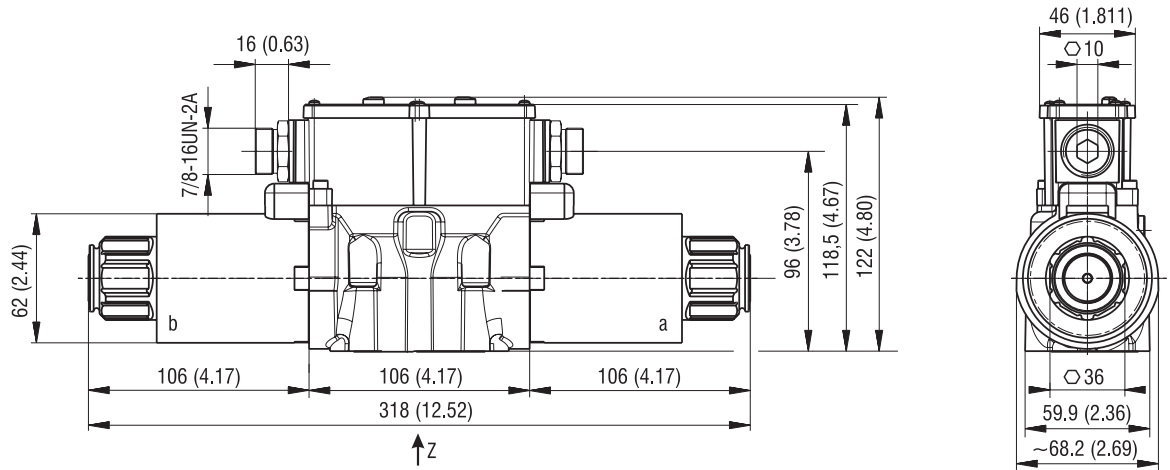

Valve with one solenoid „a”

Spool symbols R11, R21, Y51, C51, Z51, H51
RPEW4-102*/*EW1*

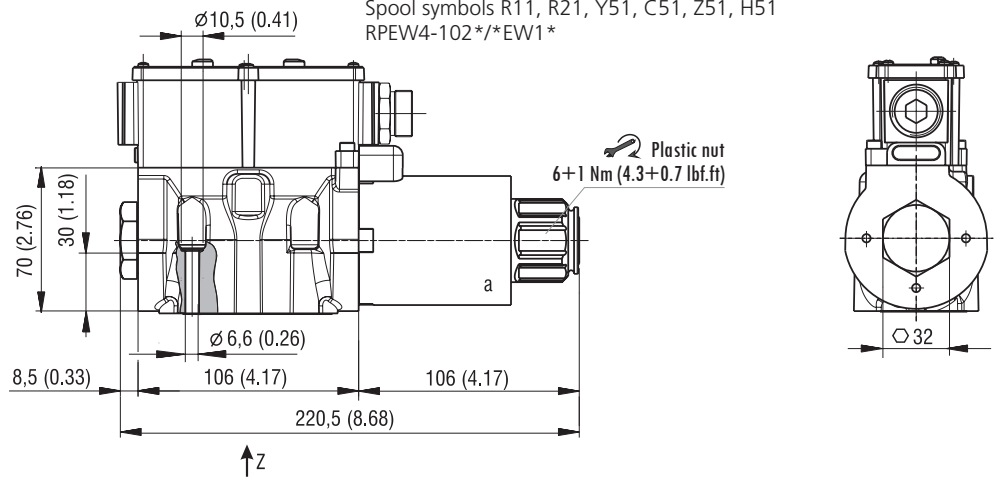

Valve with one solenoid „b”

Spool symbols C11, H11
RPEW4-102*/*EW1*

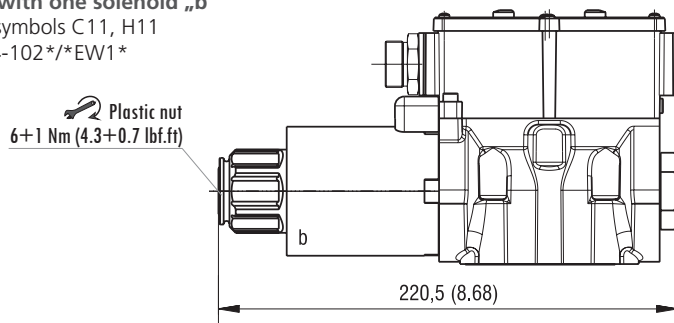

Mounting screws  14 Nm (10.3 lbf.ft)
M6 x 45 DIN 912-10.9