

Hydraulic Power Pack with Under Oil Motor

SPA 01

Q_{max} 10 l/min • p_{max} 250 bar • P_{max} 3 kW

Example: plastic tank version

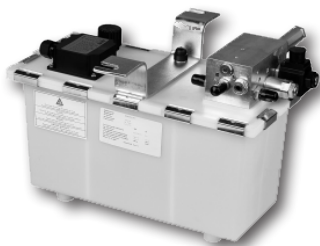

Example: steel tank version additional valves in stacking assembly

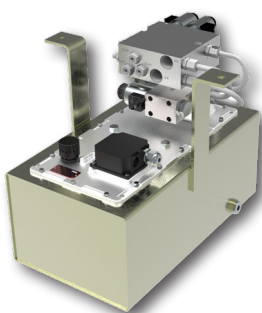

Technical Features

- › AC electro-hydraulic compact unit with under oil motor
- › Compact design with reduced overall dimensions for production cost saving
- › Main applications are lifting platforms
- › 3 central block basic circuits option
- › Possibility of building up an additional circuit in the form of vertical or horizontal stacking assembly
- › One- and three-phase motors with power ratings of up to 3 kW
- › Tank capacities from 7 to 30 l with optional plastic tanks for cost saving
- › In the standard version, the aluminium basic block is without surface protection and steel plate are zinc coated for 240 h protection acc. to ISO 9227

Functional Description

The under oil power packs are designed for applications which require low noise levels as well as small envelope dimensions. They are designed to operated only occasionally, thus being suitable mainly for the use in lifting platforms, elevating tables and handling devices. Each power pack consists of an electric motor, a pump, a manifold and a tank. The aluminum body forms the base of the power pack, on which all the main components, including the hydraulic elements, are mounted. The function of the power packs is apparent from the respective hydraulic circuit diagrams. The desired combination of particular components and hydraulic elements can be defined by reference to the ordering code and the respective tables. The additional hydraulic circuits can be built up valve sizes 03 (RPEK), 04 (CETOP 02) and 06 (CETOP 03). The size 03 (RPEK) is in the form of a sectional directional valve.

The mounting position of the power pack is horizontal - see Power Pack Dimensions. The basic combinations of electric motors and pumps, as well as their code designations, are shown in table 1.

Technical Data

Flow rate	l/min	see table 1
Working pressure	bar	see table 1
Max. operating pressure	bar	see table 1
Tank capacity	l	7, 10, 20, 30
Type of hydraulic pump		Gear pump, CLOCKWISE
Electrical Motor power ratings	kW	0.55 - 3
Type of electric motor		one- and three-phase
Voltage of electric motor	V	230 400
Duty cycle S3 of electric motor	%	20
Frequency	Hz	50
Protection degree of power unit		IP 55
Viscosity range	mm ² /s	20 ... 100
Fluid temperature range	°C	-20 ... +80
Ambient temperature max.	°C	+50
Thread of functional ports P, T, M		G1/4
	Data Sheet	Type
General information	GI_0060	Products and operating conditions

Ordering Code

SPA 01 - [] / [] . [] - [] - [] - [] / []

Under oil power pack

Pump displacement in cm³

0.8	08	3.6	36
1.2	12	4.4	44
1.6	16	4.8	48
2.1	21	5.8	58
2.5	25	6.2	62
3.3	33	7.9	79

Code of the electric motor - see table 1

Start-up module

without start-up module
with start-up module

0
M

Type of the block - see page 3

Code of the tank

7 l	7
10 l	10
20 l	20
30 l	30

Solenoid voltage

01200	12 V DC	06000	60 V DC
01400	14 V DC	10200	102 V DC
02100	21 V DC	20500	205 V DC
02400	24 V DC	02450	24 V / 50 (60) HZ
04200	42 V DC	11550	115 V / 50 (60) HZ
04800	48 V DC	23050	230 V / 50 (60) HZ

Nominal size of stacking assembly elements

without stacking assembly
size 03
size 04
size 06

0
3
4
6

Number of add-on units

without stacking assembly
1 section
2 sections
3 sections
4 sections
5 sections

0
1
2
3
4
5

Tab. 1a

Code of the electric motor			Code of the pump					
			08 GP1..	12 GP1..	16 GP1..	21 GP1..	25 GP1..	33 GP1..
p_{max}^{**} [bar]			250					
rpm [1/min]	400 V	kW	Q/p_n^* [l/min]/[bar]					
1500	13	0.55		1.5/175	2.0/130	2.6/100	3.1/85	4.2/65
	14	0.75			1.9/190	2.5/145	3.0/120	3.9/90
	15	1.10			2.1/200	2.8/190	3.3/160	4.4/120
	16	1.50					3.2/200	4.2/170
	17	2.20						
	18	3.0						
3000***	30	0.55	2.2/120	3.2/80	4.3/60	5.6/45	6.7/40	8.9/30
	31	0.75	2.2/160	3.2/110	4.3/80	5.6/65	6.7/55	8.9/40
	32	1.10	2.2/200	3.2/165	4.3/120	5.6/95	6.7/80	8.9/60
	33	1.50		3.2/200	4.3/165	5.6/130	6.7/110	8.9/80
	34	2.20			4.2/200	5.5/190	6.6/160	8.7/120
	35	3.00					6.4/200	8.5/170
rpm [1/min]	230 V	kW	Q/p_n^* [l/min]/[bar]					
1500	5	0.55		1.6/165	2.1/125	2.7/100	3.2/80	4.3/60
	6	0.75		1.6/200	2.1/170	2.8/130	3.3/110	4.4/80
	7	1.10				2.8/190	3.3/160	4.4/120
	8	1.50					3.3/200	4.4/165

Tab. 1b

Code of the electric motor			Code of the pump					
			36 GP1..	44 GP1..	48 GP1..	58 GP1..	62 GP1..	79 GP1..
p_{max}^{**} [bar]			250			200		
rpm [1/min]	400 V	kW	Q/p_n^* [l/min]/[bar]					
1500	13	0.55	4.5/60	5.5/50	6.0/45	7.3/35	7.8/35	9.9/25
	14	0.75	4.3/85	5.2/70	5.7/65	6.9/50	7.4/50	9.4/40
	15	1.10	4.8/110	5.8/90	6.3/85	7.7/70	8.2/65	10.4/50
	16	1.50	4.6/155	5.6/130	6.2/115	7.4/100	8.0/90	10.1/70
	17	2.20		5.0/200	5.5/190	6.6/160	7.1/150	9.0/120
	18	3.00			5.9/200	7.1/200	7.6/180	9.7/150
3000***	30	0.55						
	31	0.75	9.7/35					
	32	1.10	9.7/55	11.8/45	12.9/40	15.6/35		
	33	1.50	9.7/75	11.8/60	12.9/55	15.6/45	16.7/40	
	34	2.20	9.5/110	11.6/90	12.7/85	15.3/70	16.4/65	20.9/50
	35	3.00	9.3/155	11.3/125	12.4/115	15.0/95	16.0/90	20.4/70
rpm [1/min]	230 V	kW	Q/p_n^* [l/min]/[bar]					
1500	5	0.55	4.7/55	5.7/45	6.2/40	7.5/35	8.0/30	10.2/25
	6	0.75	4.8/75	5.9/60	6.4/55	7.7/45	8.3/45	10.5/35
	7	1.10	4.8/110	5.9/90	6.4/80	7.7/70	8.5/65	10.5/50
	8	1.50	4.8/150	5.9/120	6.4/110	7.7/95	8.5/85	10.5/70

* p_n - nominal pressure = the highest working pressure allowed without time restriction

** p_{max} - maximum pressure = maximum pressure allowed for a short time - max. 20 s

***Before motor selection contact the producer.

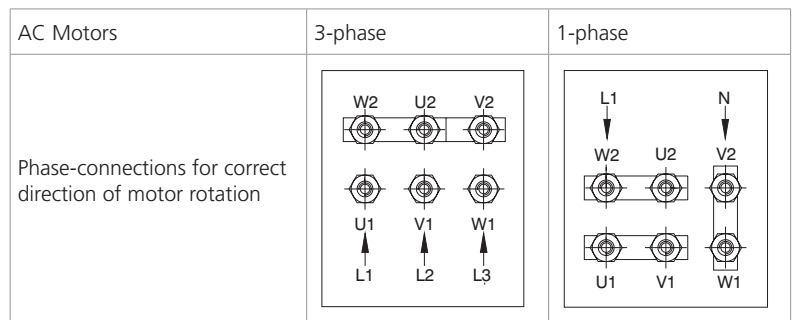

Type of the Block

S11.0 Connecting face for valves size 04, 06

S11.1 Connecting face for valves size 03

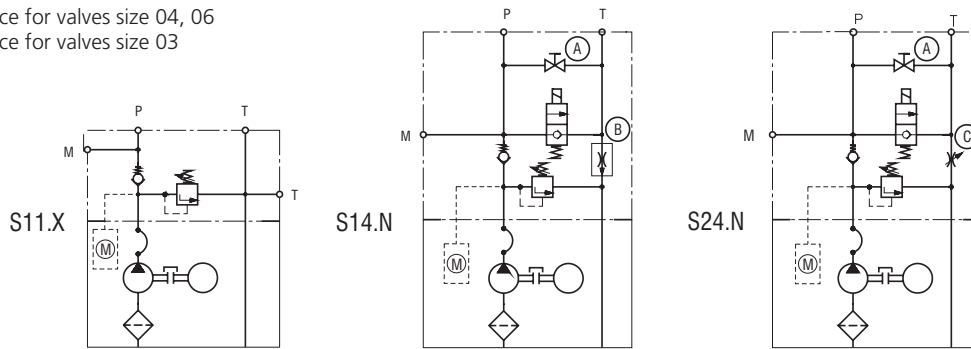

The hydraulic circuit **S11.X** enables the power pack to be used as a simple pressure supply for general applications with the possibility to build up additional hydraulic circuits in the form of horizontal stacking assemblies of the size 04 or 06 (S11.0) or size 03 (S11.1).

The hydraulic circuits **S14.N** and **S24.N** enable the power pack to be used as pressure supply for lifting platforms and other devices, in which the mass of the system provides returning into the basic position. The shut-off valve (A) enables emergency lowering of the device, should a disconnection of the supply voltage occur.

The hydraulic circuit **S14.N** comprises a flow control valve VSK (B) which is adjustable only in a certain range (see catalogue VSK - HA 5121). This valve is accessible from outside of the block. If not otherwise required, a valve VSK is mounted into the block. The stabilized flow rate of this valve corresponds with the respective flow rate of the power pack (see Tab. 1).

The hydraulic circuit **S24.N** comprises a throttle valve VSV1-06 (C) without pressure compensation. This valve is accessible from outside of the block.

M - start-up module is suitable for one-phase E-motors (codes 5-9).

Use it if there is no possibility to unload the pressure in the circuit.

Dimensions in millimeters (inches)

Steel tank

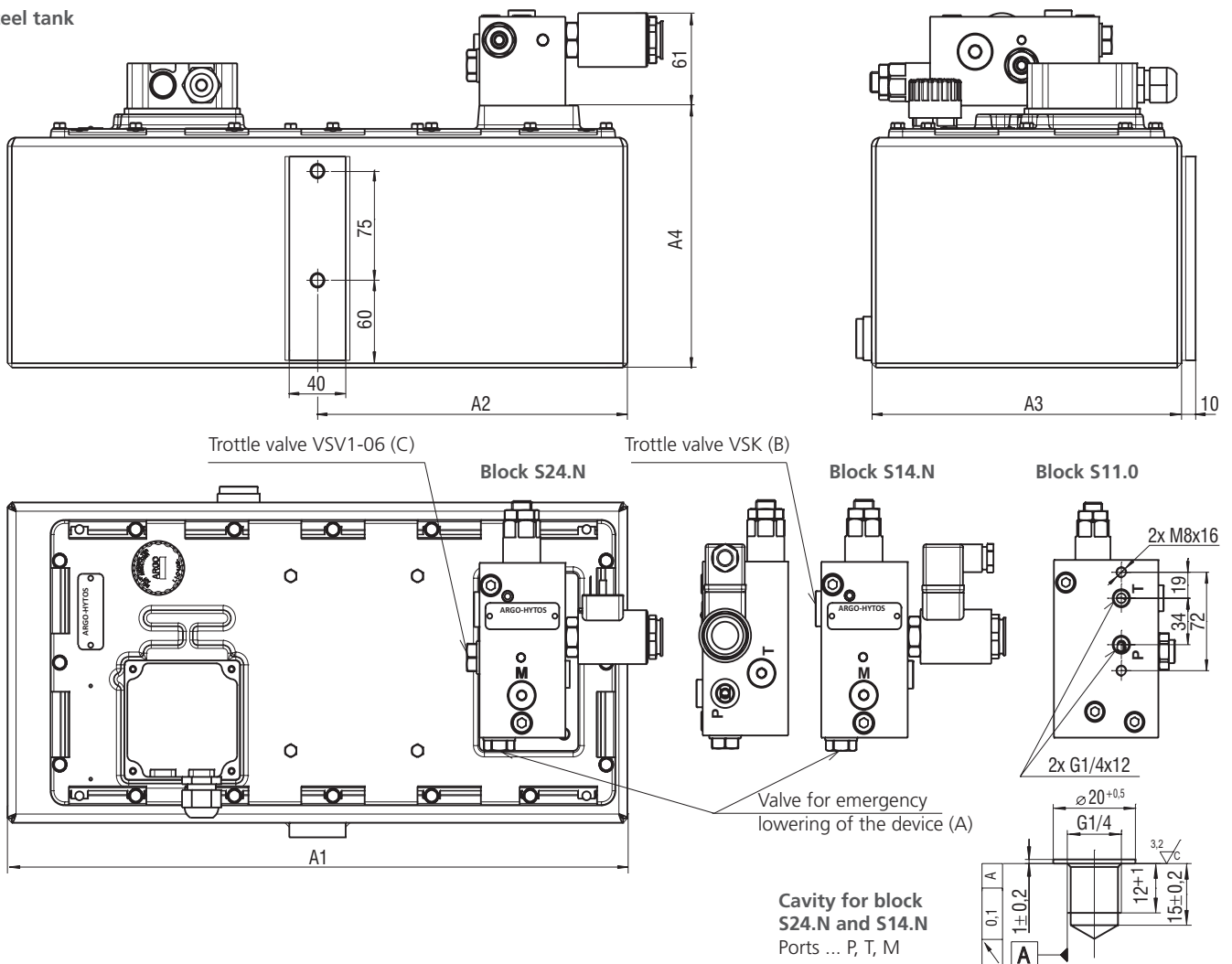

Code of the tank	Tank Capacity [l]	Working volume [l]	A1 [mm]	A2 [mm]	A3 [mm]	A4 [mm]
10 (steel)	10	6	440	220	220	180
20 (steel)	20	10	500	220	260	222
30 (steel)	30	20	500	220	260	302

Dimensions in millimeters (inches)

Plastic tank

Plastic tanks are not UV stable. Place the unit in the shade for outdoor application.

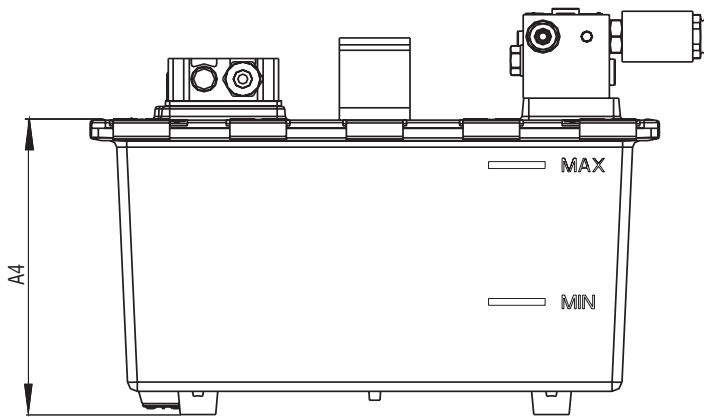

Cavity for block
S24.N and S14.N
Ports ... P, T, M

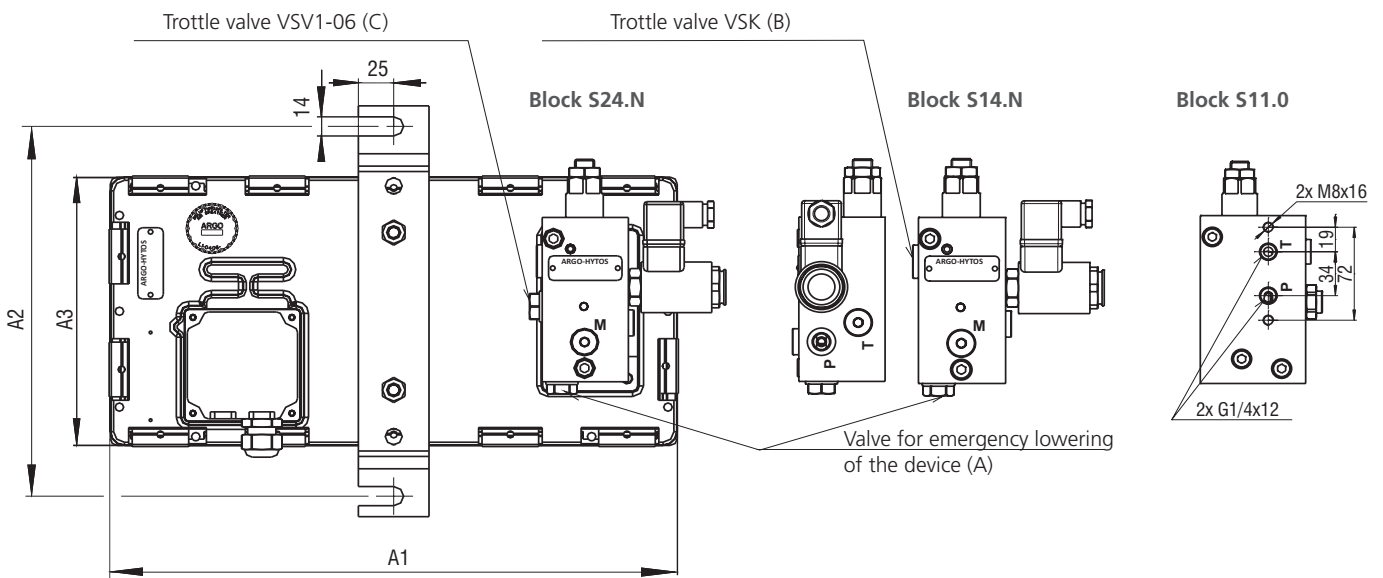
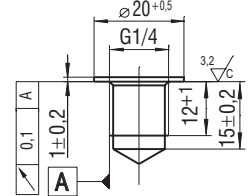

Code of the tank	Tank Capacity [l]	Working volume [l]	A1 [mm]	A2 [mm]	A3 [mm]	A4 [mm]
7 (plastic)	7	4	401	270	196	215

Example of horizontal stacking assembly

- possible only with hydraulic circuit S11.0

- possible only with hydraulic circuit S11.1

E - according to the elements used,
see datasheet of modular elements
HA 5021, HA 5023, HA 5051, HA 5093

F - Size 04=40 mm
Size 06=50 mm

G- Size 04=79 mm
Size 06=92 mm

