

TT Series Oil / Air Cooler

11cm³ hydraulic drive

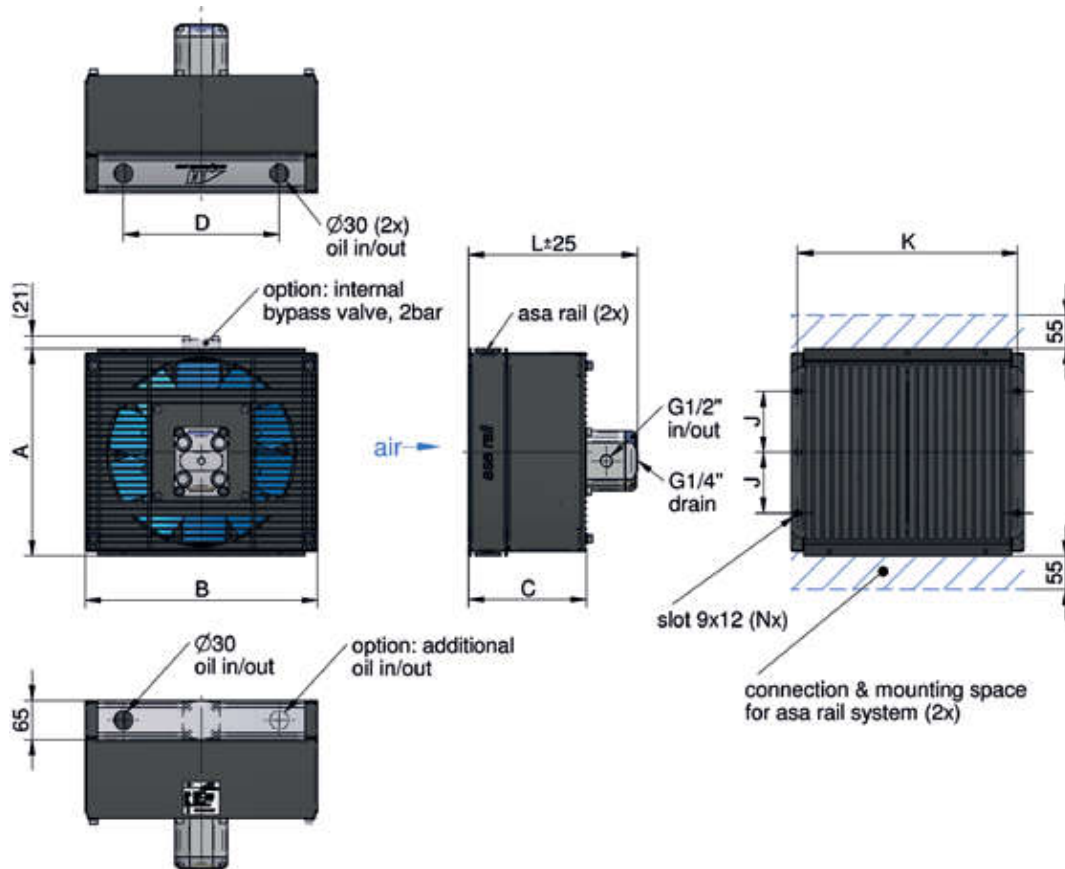

Dimensions

| order number | description | A | B | C | D | J | K | L | N | weight |
|--------------|--|------|------|------|------|-------|------|------|---|--------|
| | | [mm] | [mm] | [mm] | [mm] | [mm] | [mm] | [mm] | | [kg] |
| ASATT11RH11 | TT 11 rail 11cm ³ hydr. motor | 340 | 380 | 194 | 255 | 100 | 360 | 276 | 6 | 17,0 |
| ASATT16RH11 | TT 16 rail 11cm ³ hydr. motor | 465 | 462 | 219 | 328 | 153 | 436 | 292 | 6 | 24,5 |
| ASATT25RH11 | TT 25 rail 11cm ³ hydr. motor | 605 | 558 | 219 | 422 | 208,5 | 530 | 292 | 6 | 32,5 |

Technical Data

| order number | description | motor power | oil pressure | oil flow | rotation | air flow | noise level | optional internal bypass (2 bar) |
|--------------|--|-------------|--------------|----------|----------|----------|-------------|----------------------------------|
| | | [kW] | [bar] | [lpm] | [rpm] | [kg/s] | [dB(A)] | cooler order number |
| ASATT11RH11 | TT 11 rail 11cm ³ hydr. motor | 0,02 | 1 | 12 | 1000 | 0,33 | 66 | ASATT11RH11BP |
| | | 0,19 | 6 | 23 | 2000 | 0,67 | 82 | |
| | | 0,65 | 12 | 35 | 3000 | 1,02 | 90 | |
| ASATT16RH11 | TT 16 rail 11cm ³ hydr. motor | 0,08 | 4 | 12 | 1000 | 0,47 | 63 | ASATT16RH11BP |
| | | 0,67 | 19 | 23 | 2000 | 0,93 | 81 | |
| | | 2,26 | 43 | 35 | 3000 | 1,42 | 93 | |
| ASATT25RH11 | TT 25 rail 11cm ³ hydr. motor | 0,15 | 9 | 12 | 1000 | 1,37 | 72 | ASATT25RH11BP |
| | | 1,19 | 34 | 23 | 2000 | 2,81 | 90 | |
| | | 4,01 | 77 | 35 | 3000 | 4,24 | 101 | |

This data sheet and the corresponding scale drawings are to be used as a general guideline and technical overview of our products. Please contact us if more exact information is needed. As we are constantly improving our products, their characteristics, dimensions and weights may also change, although we do our best to incorporate these changes continually. asa assumes no liability for any information therein, any errors, omissions, misprints, nor any direct or indirect damages, losses or costs resulting therefrom. Any cooling performances and general technical values indicated in this catalogue are measured at a test bench according to asa testing procedures or calculated, based on such tests. Due to different conditions in testing and application environments the performance may also vary by +/- 15%. Because there is no standardized testing procedure, tests used by other manufacturers could have different results. Therefore we recommend all products to be checked under the system operating conditions. This is also true for vibrations and mechanical stress as well as for pressure peaks and thermal stress and any other relevant factors. General tolerances according to DIN ISO 2768-v, General tolerances for casted parts according EN ISO 8062-3 (DCTG 10), Tolerances for rubber parts are according to ISO 3302-1 (class M4-F+C). The tolerances of welding seams are defined by quality group D according to EN ISO 10042, if it is not specified on the actual scale drawing or data sheet. In addition to that we point out that any data sheet and corresponding scale drawing is no substitution for the manual.

TT Series Oil / Air Cooler

11cm³ hydraulic drive



Performance

specific cooling performance

all products
water/glycol
compatibel

Contact us!

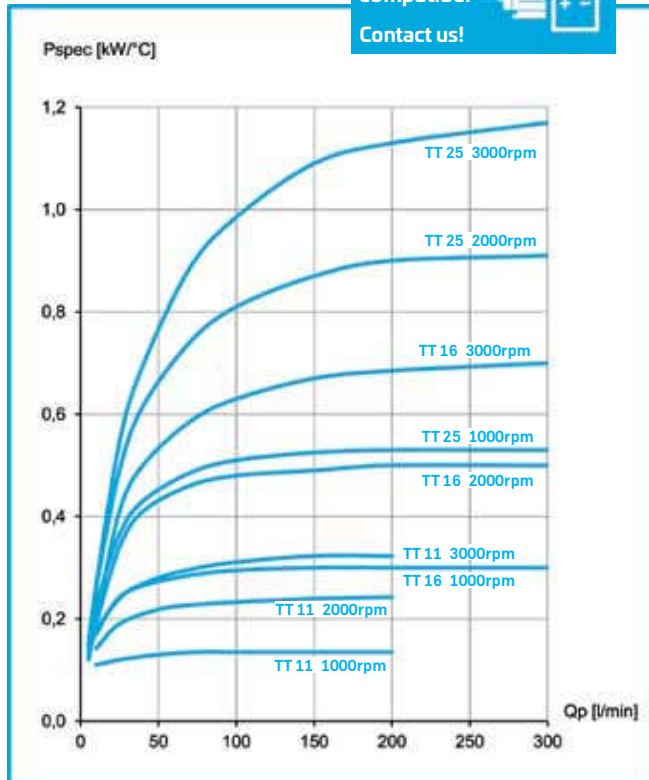

pressure drop at 30cSt

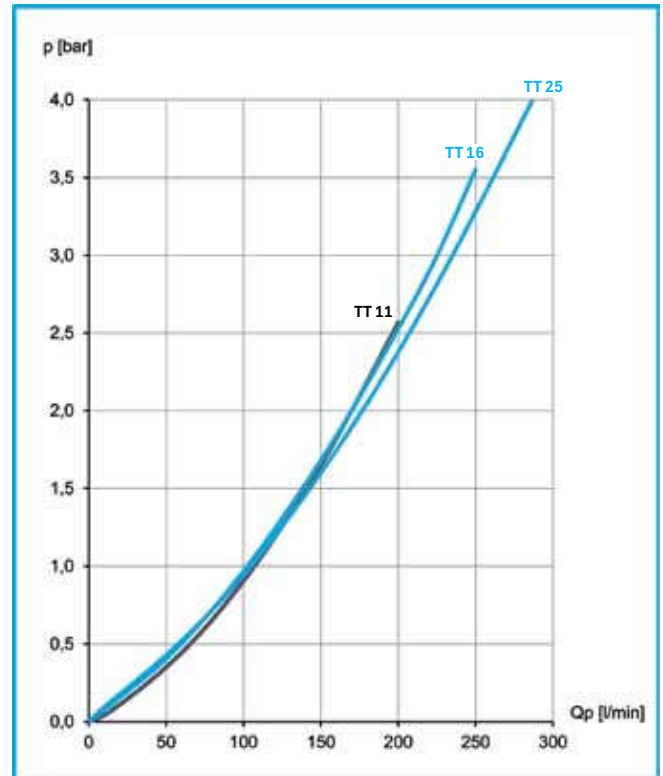

Radiator Style B

| | |
|----------------------------|-----------------------------------|
| material: | aluminium |
| working temperature range: | -20°C to +80°C (oil temperature)* |
| air fin shape: | wavy |
| working pressure: | 26 bar (static) |

*...the indicated temperature is the maximum inlet temperature for the cooler radiator. Depending on the sealings in use, the application needs appropriate checking.

Options

| | |
|-----------------------|---|
| hydraulic motor | alternative displacements on request |
| temperature switches | ILLZTH5069K, ILLZTH6069K, ILLZTH9069K (page 39) |
| foot mounting options | ILLEFUSSTTK, ILLEFUSSTTHDK (page 34) |
| internal bypass | alternative bypass settings (1bar / 5bar) |

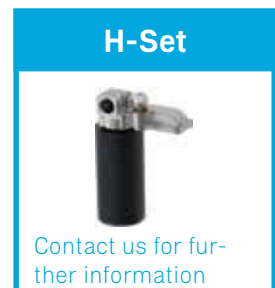

Installation System (see more information on page 32)

| | |
|-----------------------|---|
| connection BSP 1" | ILLZSET5G25 (1 set per cooler required) |
| connection BSP 1 1/4" | ILLZSET5G32 (1 set per cooler required) |



This data sheet and the corresponding scale drawings are to be used as a general guideline and technical overview of our products. Please contact us if more exact information is needed. As we are constantly improving our products, their characteristics, dimensions and weights may also change, although we do our best to incorporate these changes continually. asa assumes no liability for any information therein, any errors, omissions, misprints, nor any direct or indirect damages, losses or costs resulting therefrom. Any cooling performances and general technical values indicated in this catalogue are measured at a test bench according to asa testing procedures or calculated, based on such tests. Due to different conditions in testing and application environments the performance may also vary by +/- 15%. Because there is no standardized testing procedure, tests used by other manufacturers could have different results. Therefore we recommend all products to be checked under the system operating conditions. This is also true for vibrations and mechanical stress as well as for pressure peaks and thermal stress and any other relevant factors. General tolerances according to DIN ISO 2768-v, General tolerances for casted parts according EN ISO 8062-3 (DCTG 10), Tolerances for rubber parts are according to ISO 3302-1 (class M4-F+C). The tolerances of welding seams are defined by quality group D according to EN ISO 10042, if it is not specified on the actual scale drawing or data sheet. In addition to that we point out that any data sheet and corresponding scale drawing is no substitution for the manual.

ASA Series Oil / Air Cooler

11cm³ hydraulic drive

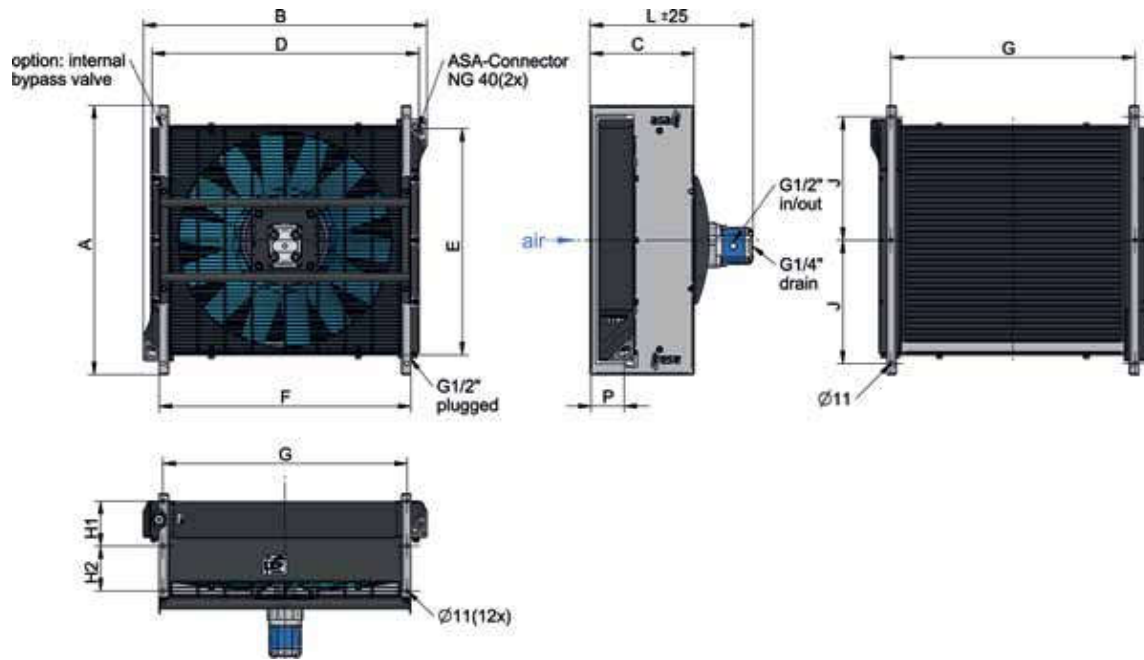

Dimensions

| order number | description | A | B | C | D | E | F | G | H1 | H2 | J | L | P | weight |
|--------------|--|------|------|------|------|------|------|------|------|------|-------|------|------|--------|
| | | [mm] | [mm] | [mm] | [mm] | [mm] | [mm] | [mm] | [mm] | [mm] | [mm] | [mm] | [mm] | [kg] |
| ASA0177AH11 | ASA 0177 hydr. motor 11cm ³ | 530 | 582 | 260 | 534 | 416 | 462 | 442 | 120 | 90 | 490 | 364 | 89 | 35,8 |
| ASA0257AH11 | ASA 0257 hydr. motor 11cm ³ | 635 | 682 | 270 | 634 | 501 | 562 | 542 | 110 | 110 | 280 | 383 | 93 | 44,5 |
| ASA0367AH11 | ASA 0367 hydr. motor 11cm ³ | 720 | 762 | 280 | 715 | 596 | 676 | 656 | 120 | 120 | 330 | 430 | 92 | 56,4 |
| ASA0467AH11 | ASA 0467 hydr. motor 11cm ³ | 785 | 837 | 290 | 789 | 668 | 758 | 738 | 125 | 125 | 375 | 448 | 94 | 72,9 |
| ASA0567AH11 | ASA 0567 hydr. motor 11cm ³ | 860 | 920 | 290 | 865 | 746 | 826 | 806 | 125 | 125 | 400 | 448 | 92 | 74,1 |
| ASA0727AH11 | ASA 0727 hydr. motor 11cm ³ | 960 | 1012 | 360 | 964 | 852 | 936 | 912 | 160 | 160 | 460 | 521 | 95 | 103 |
| ASA0927AH11 | ASA 0927 hydr. motor 11cm ³ | 1100 | 1170 | 320 | 1115 | 912 | 1058 | 1031 | 130 | 130 | 522,5 | 475 | 87 | 125 |

Technical Data

| order number | description | motor power | oil pressure | oil flow | rotation | air flow | noise level | optional internal bypass (2 bar) |
|--------------|---|-------------|--------------|----------|----------|----------|-------------|----------------------------------|
| | | [kW] | [bar] | [lpm] | [rpm] | [kg/s] | [db(A)] | cooler order number |
| ASA0177AH11 | ASA 0177 hydr. motor 11 cm ³ | 0,06 | 3 | 12 | 1000 | 0,42 | 61 | ASA0177AH11BP |
| | | 0,47 | 14 | 23 | 2000 | 0,73 | 79 | |
| | | 1,58 | 30 | 35 | 3000 | 0,97 | 91 | |
| ASA0257AH11 | ASA 0257 hydr. motor 11 cm ³ | 0,12 | 7 | 12 | 1000 | 0,81 | 73 | ASA0257AH11BP |
| | | 0,95 | 27 | 23 | 2000 | 1,63 | 80 | |
| | | 3,20 | 61 | 35 | 3000 | 2,44 | 89 | |
| ASA0367AH11 | ASA 0367 hydr. motor 11 cm ³ | 0,20 | 12 | 12 | 1000 | 0,94 | 73 | ASA0367AH11BP |
| | | 0,68 | 26 | 17 | 1500 | 1,53 | 85 | |
| | | 1,60 | 48 | 23 | 2000 | 2,20 | 90 | |
| ASA0467AH11 | ASA 0467 hydr. motor 11 cm ³ | 0,24 | 14 | 12 | 1000 | 1,15 | 77 | ASA0467AH11BP |
| | | 0,80 | 31 | 17 | 1500 | 1,75 | 87 | |
| | | 1,91 | 55 | 23 | 2000 | 2,32 | 90 | |
| ASA0567AH11 | ASA 0567 hydr. motor 11 cm ³ | 0,23 | 13 | 12 | 1000 | 1,21 | 77 | ASA0567AH11BP |
| | | 0,78 | 30 | 17 | 1500 | 1,89 | 87 | |
| | | 1,86 | 54 | 23 | 2000 | 2,90 | 90 | |
| ASA0727AH11 | ASA 0727 hydr. motor 11 cm ³ | 0,70 | 40 | 12 | 1000 | 3,75 | 84 | ASA0727AH11BP |
| | | 2,30 | 88 | 17 | 1500 | 5,82 | 93 | |
| | | 5,50 | 158 | 23 | 2000 | 7,83 | 99 | |
| ASA0927AH11 | ASA 0927 hydr. motor 11 cm ³ | 1,61 | 93 | 12 | 1000 | 5,78 | 88 | not available |
| | | 3,54 | 157 | 15 | 1300 | 7,73 | 92 | |
| | | 6,60 | 238 | 19 | 1600 | 9,72 | 97 | |

This data sheet and the corresponding scale drawings are to be used as a general guideline and technical overview of our products. Please contact us if more exact information is needed. As we are constantly improving our products, their characteristics, dimensions and weights may also change, although we do our best to incorporate these changes continually. asa assumes no liability for any information therein, any errors, omissions, misprints, nor any direct or indirect damages, losses or costs resulting therefrom. Any cooling performances and general technical values indicated in this catalogue are measured at a test bench according to asa testing procedures or calculated, based on such tests. Due to different conditions in testing and application environments the performance may also vary by +/- 15%. Because there is no standardized testing procedure, tests used by other manufacturers could have different results. Therefore we recommend all products to be checked under the system operating conditions. This is also true for vibrations and mechanical stress as well as for pressure peaks and thermal stress and any other relevant factors. General tolerances according to DIN ISO 2768-v, General tolerances for casted parts according EN ISO 8062-3 (DCTG 10). Tolerances for rubber parts are according to ISO 3302-1 (class M4-F+C). The tolerances of welding seams are defined by quality group D according to EN ISO 10042, if it is not specified on the actual scale drawing or data sheet. In addition to that we point out that any data sheet and corresponding scale drawing is no substitution for the manual.

ASA Series Oil / Air Cooler

11cm³ hydraulic drive



Performance

specific cooling performance

all products
water/glycol
compatibel

Contact us!

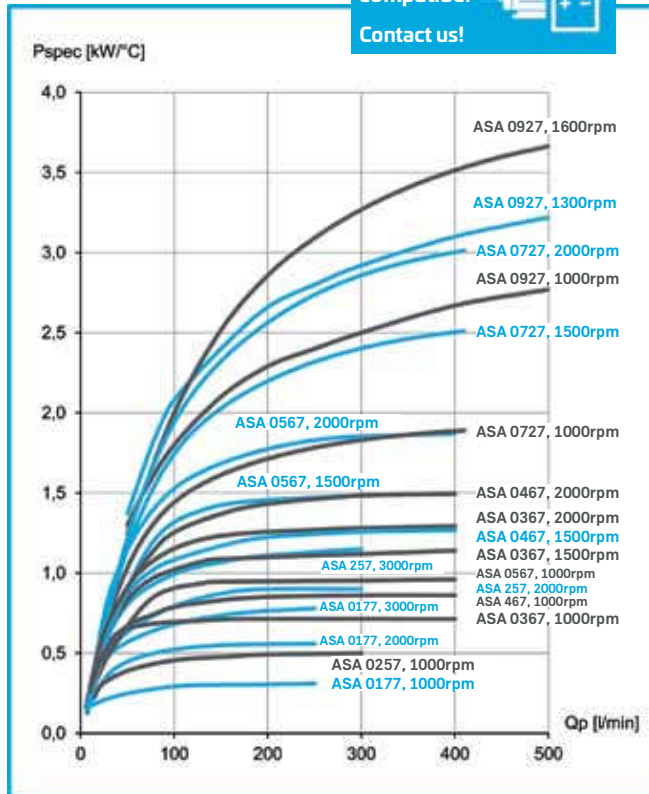

pressure drop at 30cSt

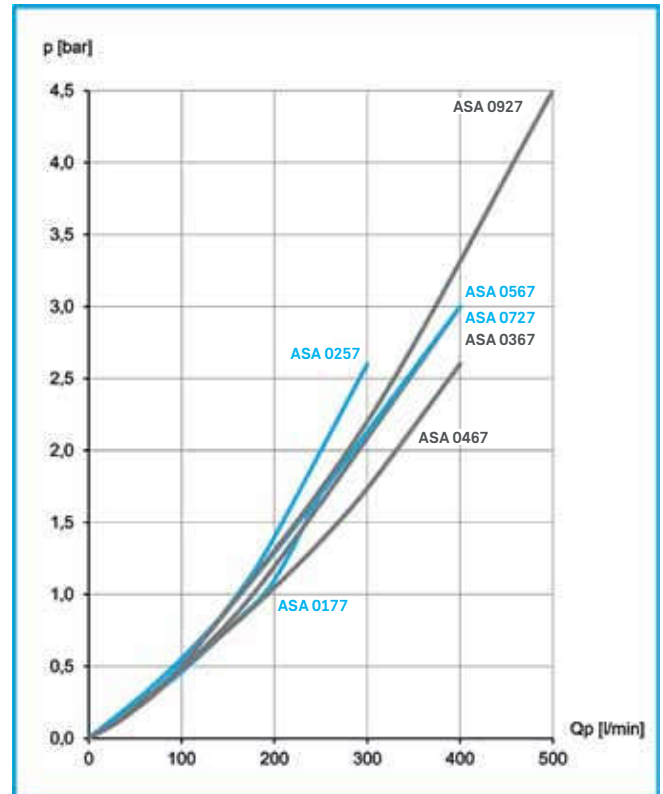

Radiator Style C

| | |
|----------------------------|----------------------------------|
| material: | aluminium |
| working temperature range: | -20°C to +80°C (oil temperature) |
| air fin shape: | wavy |
| working pressure: | 26 bar (static) |

*...the indicated temperature is the maximum inlet temperature for the cooler radiator. Depending on the sealings in use, the application needs appropriate checking.

Options

| | |
|------------------------------|---|
| hydraulic motor | alternative displacements on request |
| temperature switch | ILLZTH4765K, ILLZTH6065K (page 39) |
| tread plate & radiator guard | see page 35 |
| internal bypass | alternative bypass settings (0,5bar / 3,5bar) |
| Intermediate plate NG 40 | ILLZASA40-40G12 (page 33) |

Installation System (see more information on page 33)

| | |
|---------------------|---|
| connection BSP 1 ¼" | ILLZASA32G32 (2 pieces per cooler required) |
| connection BSP 1 ½" | ILLZASA40G40 (2 pieces per cooler required) |



This data sheet and the corresponding scale drawings are to be used as a general guideline and technical overview of our products. Please contact us if more exact information is needed. As we are constantly improving our products, their characteristics, dimensions and weights may also change, although we do our best to incorporate these changes continually. asa assumes no liability for any information therein, any errors, omissions, misprints, nor any direct or indirect damages, losses or costs resulting therefrom. Any cooling performances and general technical values indicated in this catalogue are measured at a test bench according to asa testing procedures or calculated, based on such tests. Due to different conditions in testing and application environments the performance may also vary by +/- 15%. Because there is no standardized testing procedure, tests used by other manufacturers could have different results. Therefore we recommend all products to be checked under the system operating conditions. This is also true for vibrations and mechanical stress as well as for pressure peaks and thermal stress and any other relevant factors. General tolerances according to DIN ISO 2768-v, General tolerances for casted parts according EN ISO 8062-3 (DCTG 10). Tolerances for rubber parts are according to ISO 3302-1 (class M4-F+C). The tolerances of welding seams are defined by quality group D according to EN ISO 10042, if it is not specified on the actual scale drawing or data sheet. In addition to that we point out that any data sheet and corresponding scale drawing is no substitution for the manual.