



BREVINI[®]

Motion Systems

MC HYDRAULIC POWER PACK

Technical Catalogue

May
2019

web edition

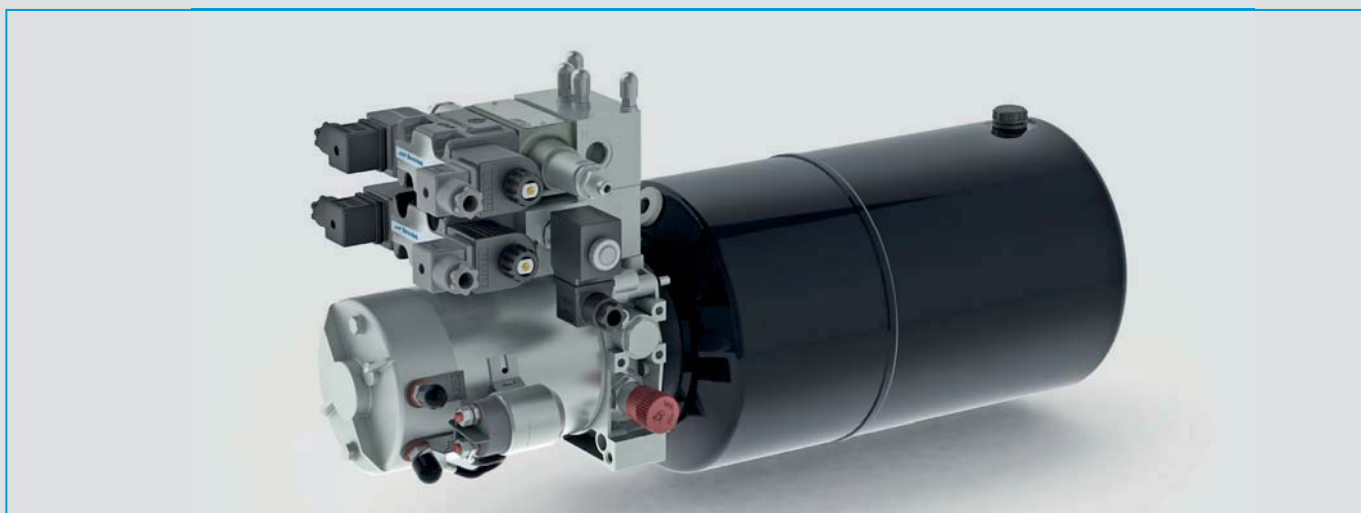

i

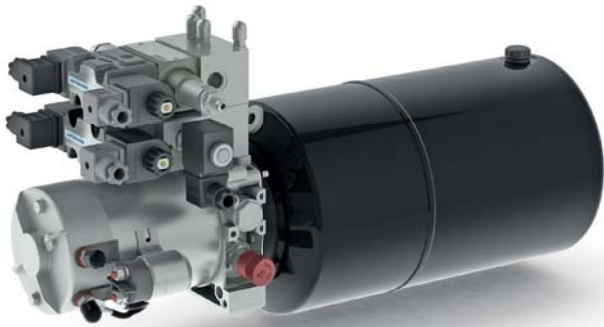

The MC series power pack is an easy-to-assemble, compact, electro-hydraulic unit. With its versatility and modularity, it offers many combinations of hydraulic circuits to suit various requirements of plant design. This catalogue has been written to help the user choose the components for the power pack required for the specific application. However, the catalogue cannot foresee all the combinations that may be executed, so in some cases it may be necessary to consult our commercial engineering department.

For applications with very complex circuits, standard modular blocks for Cetop valves and other special blocks can be installed on the power pack, or blocks built to order can be included.

A few applications:

- Fork lifts
- Lifting platforms and beds
- Automotive lifts
- Cranes for small trucks
- Snowplows
- Industrial automation (machine tools, food industry, textile industry)

You can choose from a wide variety of components with the following specifications:

- Gear pumps - Group 0.5 / 1 - from 0.25 to 9.8 cc.
- DC motors, 12/24 V, light-duty service, from 0.35 to 3 Kw
- Single and triple-phase motors with power ratings of up to 4 Kw - in a standard version or built to the customer's specifications (with minimum overall dimensions)
- Tanks in sheet steel with capacities of up to 25 litres
- Tanks in plastic with capacities of up to 10 litres

A fundamental part of the power pack is the endhead, which is made of die-cast aluminum alloy. The parts and dimensions of this component are shown below.

Operating limits

- Intermittent peak pressure: 290 bar (depending on pump type)
- Maximum flow rate: 20 l/min
- Maximum operating temperature:
 - 80°C (with sheet steel tank)
 - 70°C (with polyethylene tank)
 - 60°C (with polypropylene tank)
- Mineral-based hydraulic fluid: ISO 6743-4 (DIN 51524)
 - Minimum viscosity: 12 mm²/s
 - Maximum viscosity: 80 mm²/s
 - Maximum viscosity at start-up: 500 mm²/s
- Minimum ambient temperature -15°C
- Maximum ambient temperature 40°C (with peaks of 50°C)
- The validation of the endhead follows a life-test with 210 bar pulsed pressure repeated for 200.000 cycles



Operating pressure is controlled by the maximum pressure valve and the type of pump used (in terms of performance) may be determined by the maximum pressure valve. Therefore, it is essential not to change the maximum pressure valve. If necessary, contact our technical service department.

Installation

- 1) The power pack must be mounted using the M10 holes on the endhead.
- 2) The power pack must not come into contact with sheet metal, protective guards or any parts that may vibrate and transmit noise.
- 3) The ports on the endhead have been identified by the letters A-B-C. The hydraulic connection must be made with fittings with cylindrical thread and with copper or rubber sealing gaskets (O-rings).
- 4) After the electrical connections have been made, check the direction of motor rotation by executing short pulses of 1 second each (max.): the motor must turn anti-clockwise, as shown in the figure.

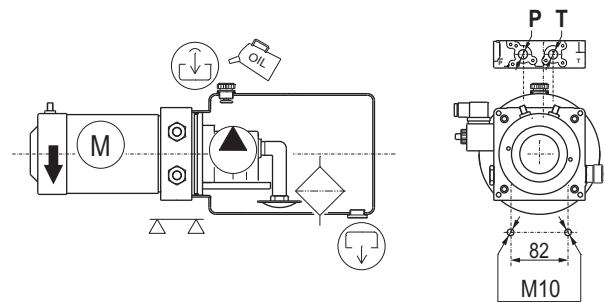

The tank must be filled with new mineral-based, ISO 6743/4 fluid: it is important to filter the fluid while filling the tank.

Symbols used in this catalog:

	Important data/information
	Mounting endhead side
	Ground floor
	Electrical connection boxes on AC motors
	Poles and/or starting relays on DC motors
	Fill plug with breather and level stick
	Fill plug with breather
	Standard plug (closed)
	Standard oil fill plug
	Fill plug with breather
	Fill plug
	Fill plug with check valve
	Fill plug with back check
	Drain plug with magnet
	Plug (or level stick) with visual indicator
	Drain plug
*	Fields to be completed

Power pack endhead configuration

MCA

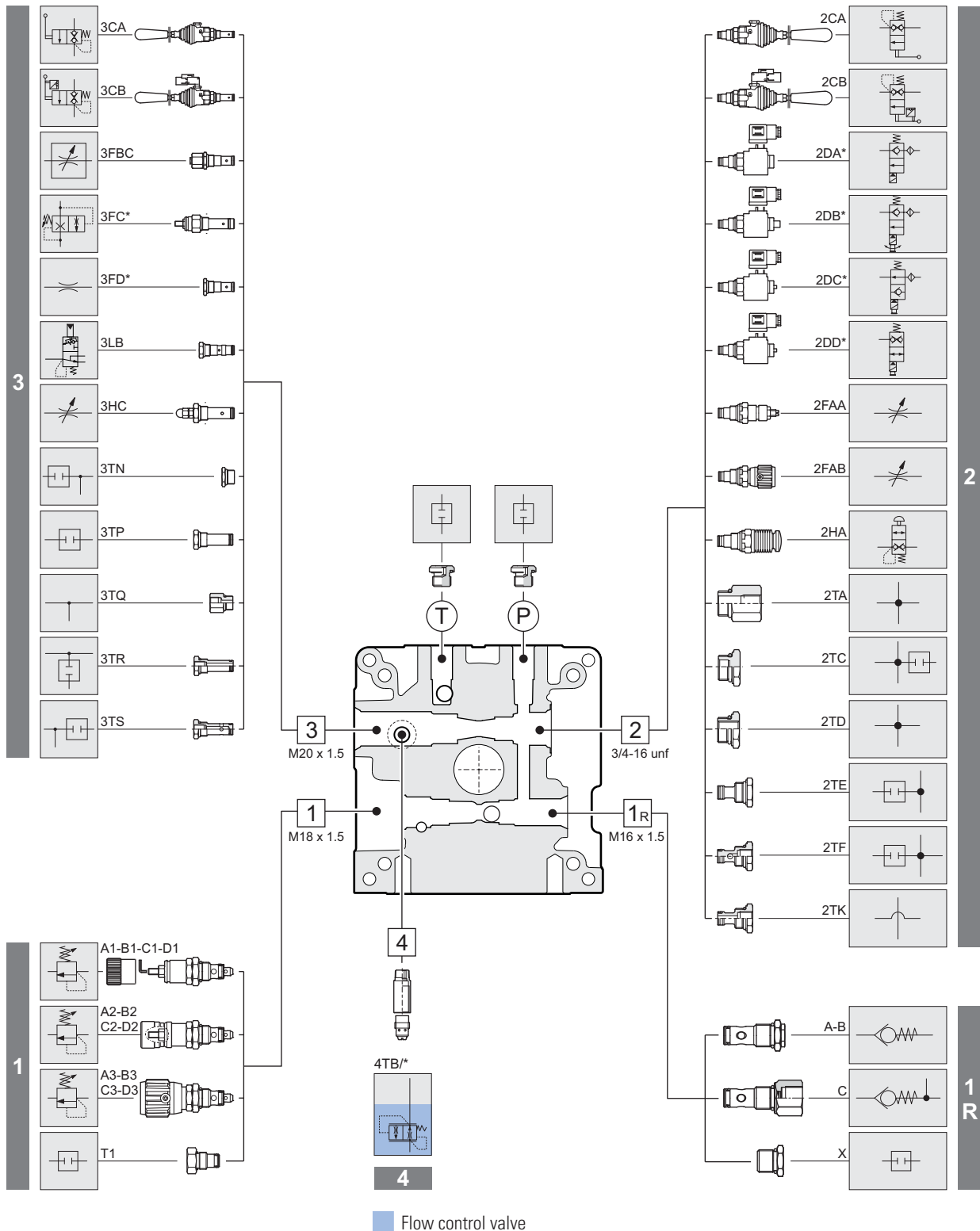

The possible configurations of the MC power pack are determined by the body machining.

MCA flange allows the mounting of controls and flow regulators in the **cavity 3** and fixed setting flow control valve on **cavity 4**.

Power pack endhead configuration

MCB

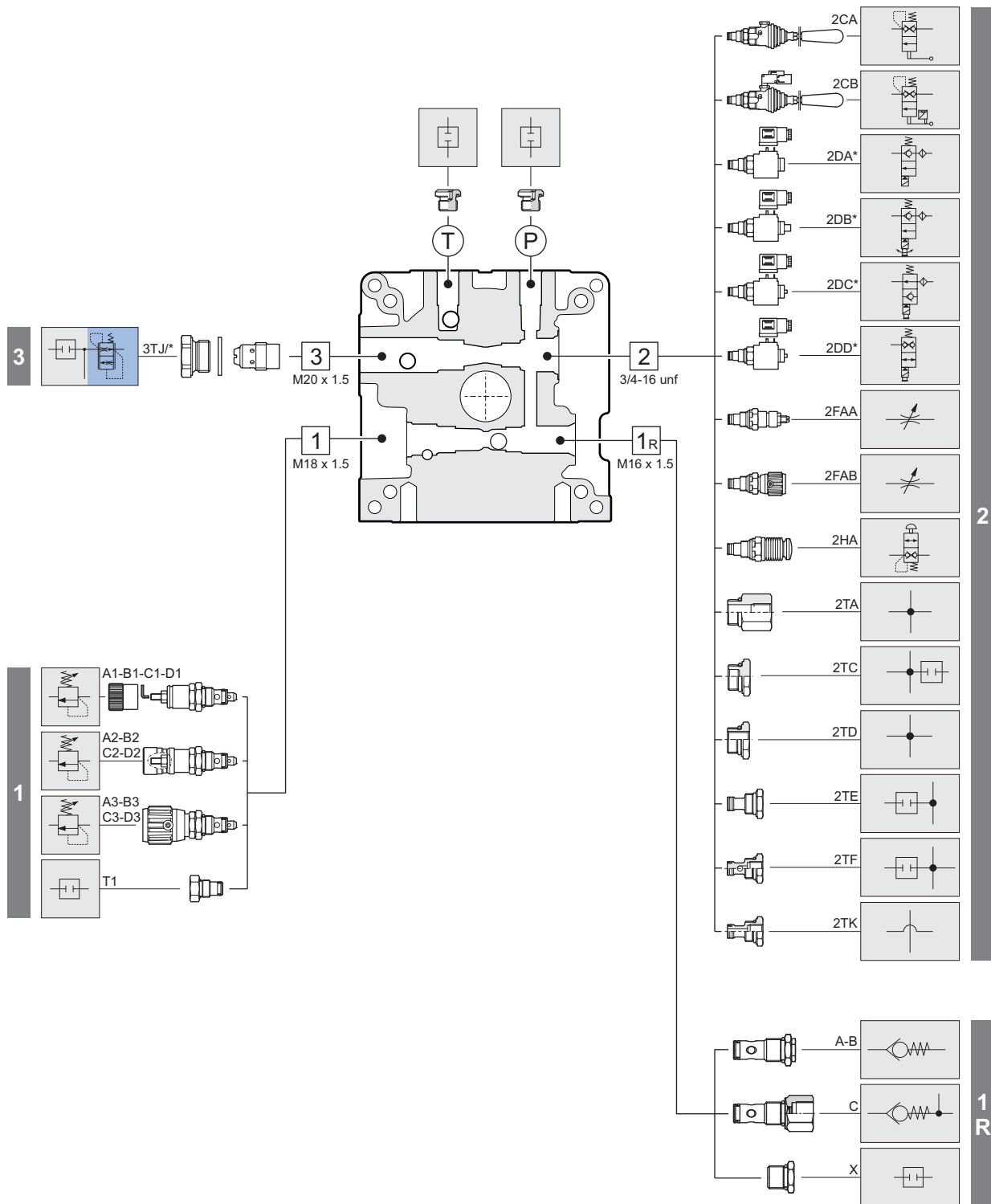

The possible configurations of the MC power pack are determined by the body machining.
MCA flange allows the mounting of controls and flow regulators fixed setting in the **cavity 3**.

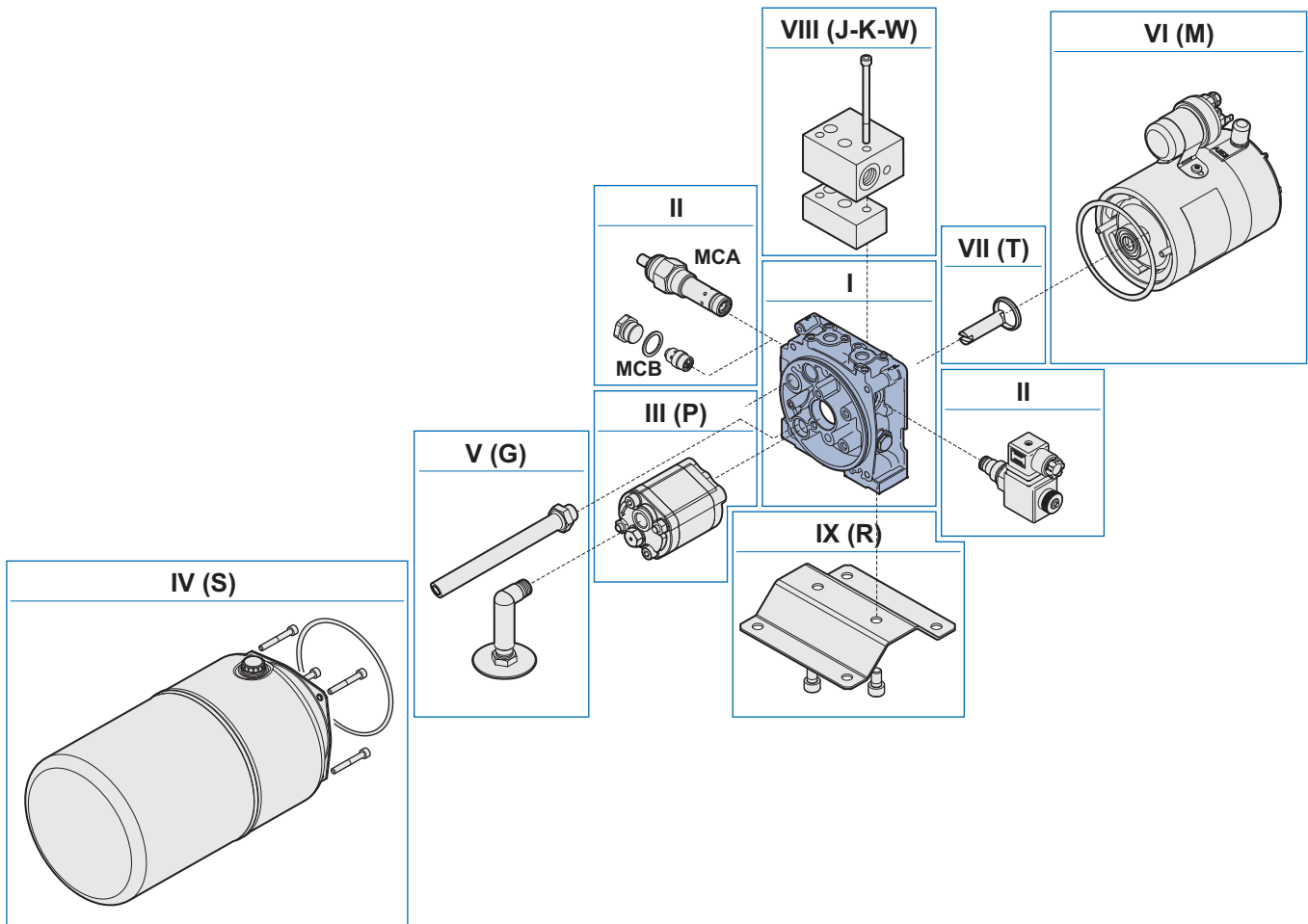

With its great modularity, the MC series of power packs can create multiple configurations which satisfy requirements in a wide range of applications. To make it easier to choose components, the power pack is subdivided into sections.

SECTION I - SERIE, FLANGE TYPE, VALVES ON CAVITY 1 AND 1R

MC Series Powerpacks are based on the Flange features. The Flange is the core of the unit, on the flange are mounted all the valves, the pump, the motor and the reservoir. The MC Flange is available in several Versions (with different tooling options). The Flange Version must be chosen depending on the type of Hydraulic Circuit Layout required. Together with the Flange Version, it is required to select the Valves to be mounted in the Various Cavities. 1 (Main Pressure Relief Valve).

SECTION II - VALVES

Depending on the Type of Hydraulic Circuit Layout to be realized, it is required to Select the Valves for each of the available Cavities. In order to correctly build up the Ordering Code, it is required to use the following procedure. Peripheral Cavities (it is mandatory to mention all the Cavities in Numeral Order): starting from Cavity 2, mention all the Cavities and the Valves, Plugs or Fittings to be mounted in said Cavity. Internal Cavities, mention the Internal Cavities where a Valve (usually a Return Line Valve) is mounted. Outputs, see description in the Table.

SECTION III - PUMPS

It is mandatory to mention this section, defined by the letter P. Depending on the required features, select the pump from the table provided.

SECTION IV - TANKS

This section is defined by the letter S.

Depending on the required features, select the reservoir from the list provided. If no Reservoir is required, and also no Suction / Return Kit is required, please omit this section.

If no Reservoir is required, but a Suction / Return Kit is required, please jump to Section V (defined by letter G).

SECTION V - TUBES KIT (suction and return, only for tanks on the catalog)

This section is defined by the letter G. In order to define this Section, please select the Reservoir Type anyways.

SECTION VI - MOTORS

This section is defined by the letter M. Depending on the Type of Hydraulic Circuit Layout to be realized, it is required to Select the Motor Type. If no Motor is required, and no Transmission Kit is required, please omit this section. If no Motor is required, but a Transmission Kit is required, please jump to Section VII (defined by letter T).

SECTION VII - TRANSMISSION KIT (only for motors on the catalog)

This section is defined by the letter T. Select the kit as per Table provided.

SECTION VIII - BLOCKS

This section it is not mandatory, depending on the type of auxiliary block required, the letter J, identifies blocks with interface for CETOP valves.

SECTION IX - ACCESSORIES

This section it is not mandatory, is defined by the letter R. Check the available options in the list provided. Accessories must be listed in Alphabetical Order.

SECTION I - SERIE, ENDHEAD, VALVES ON CAVITY 1 AND 1R

i

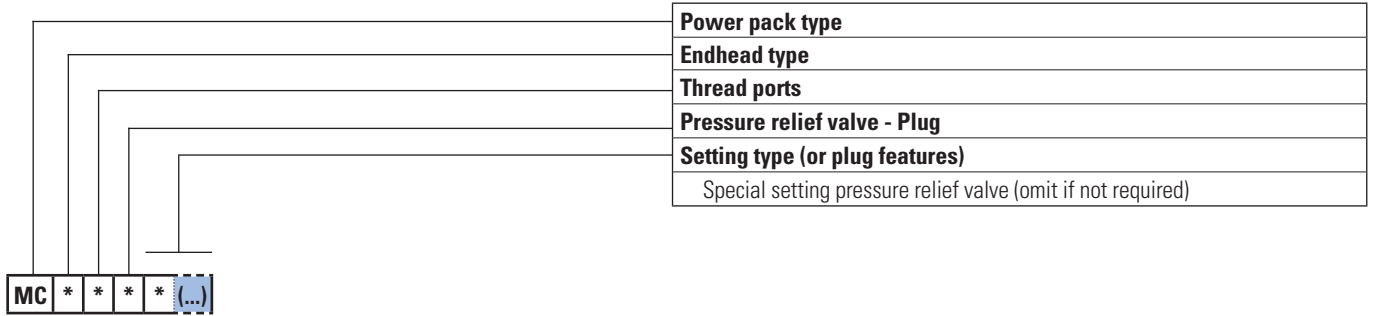

SECTION II - VALVES

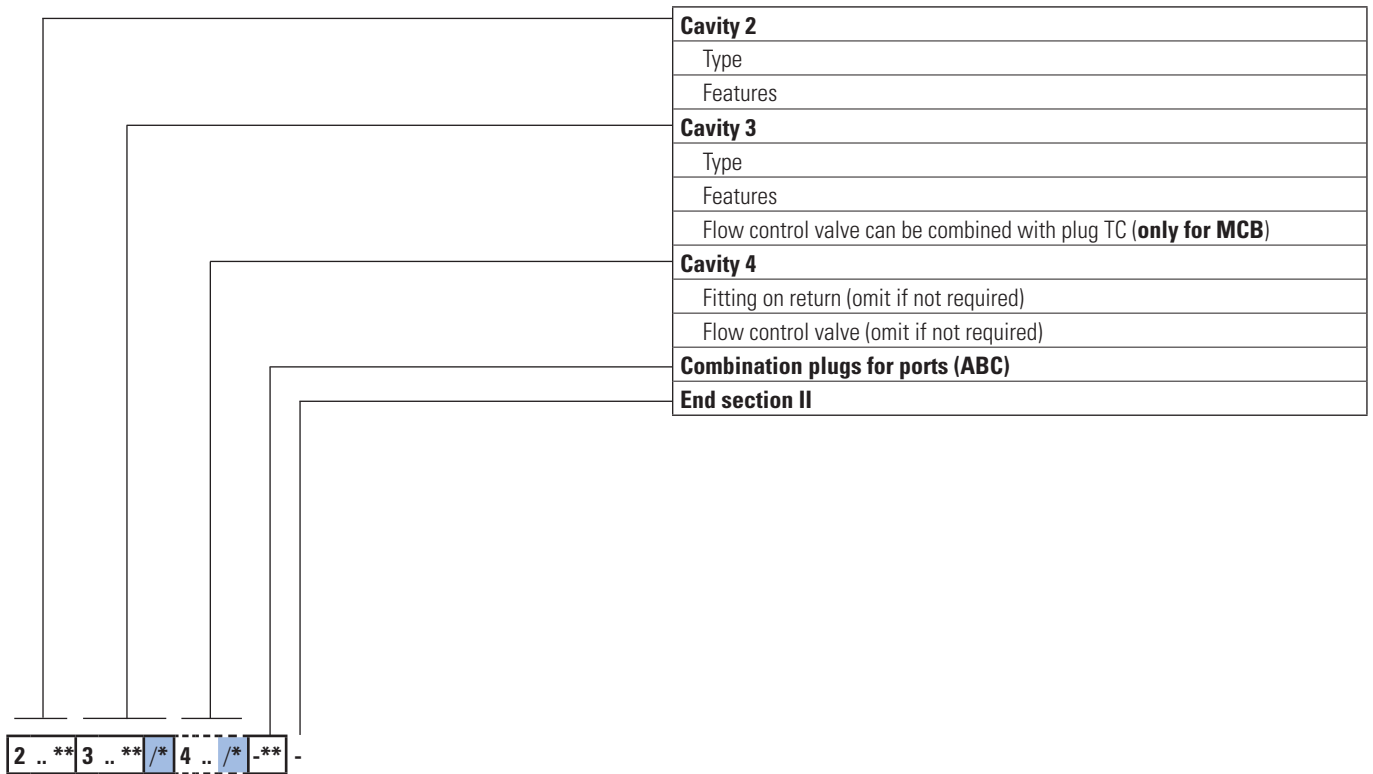

SECTION III - PUMPS

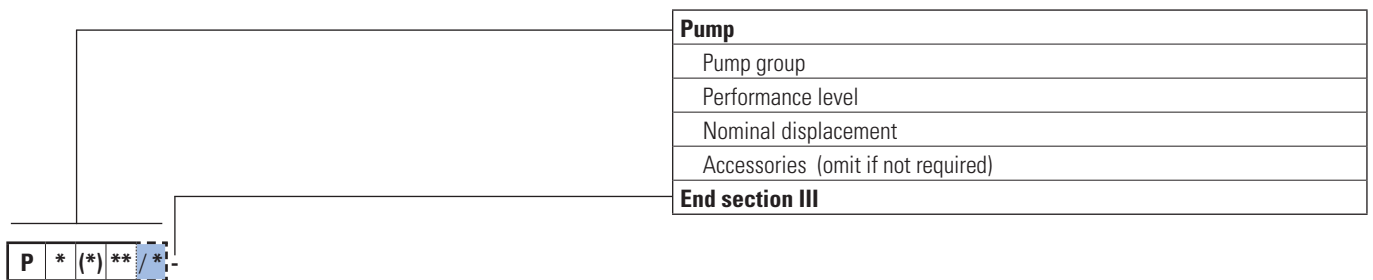

SECTION IV - TANKS / SECTION V - TUBES KIT

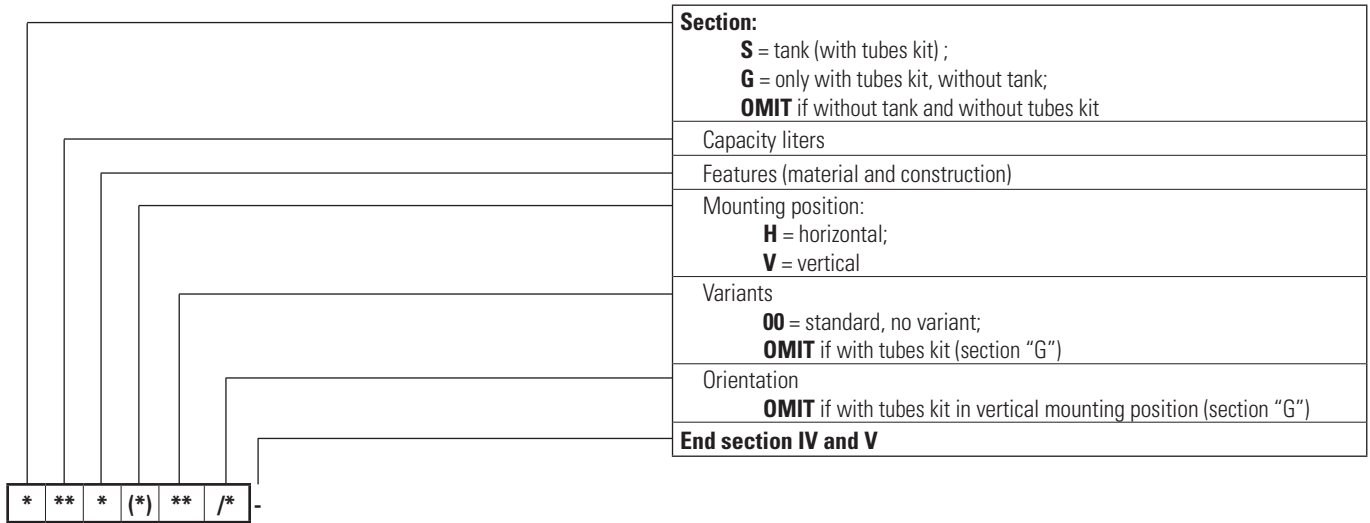

SECTION VI - MOTORS

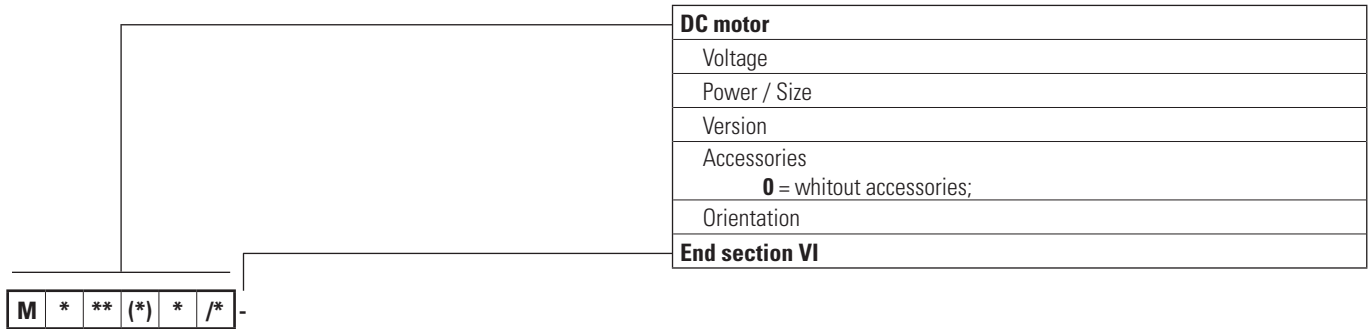

OR ..

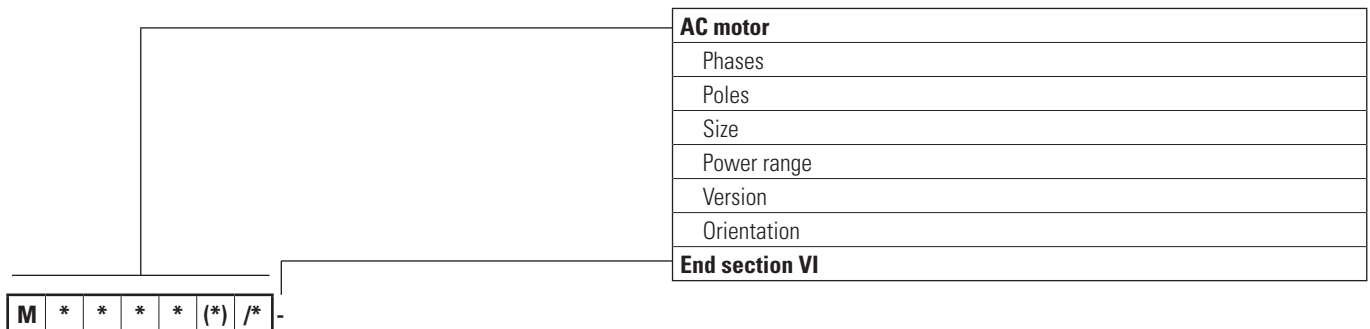

SECTION VII - TRANSMISSION KIT (only for motors on the catalog)

i

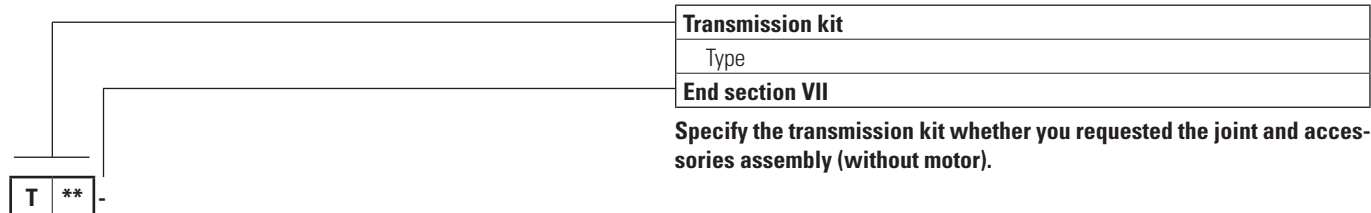

SECTION VIII - BLOCKS

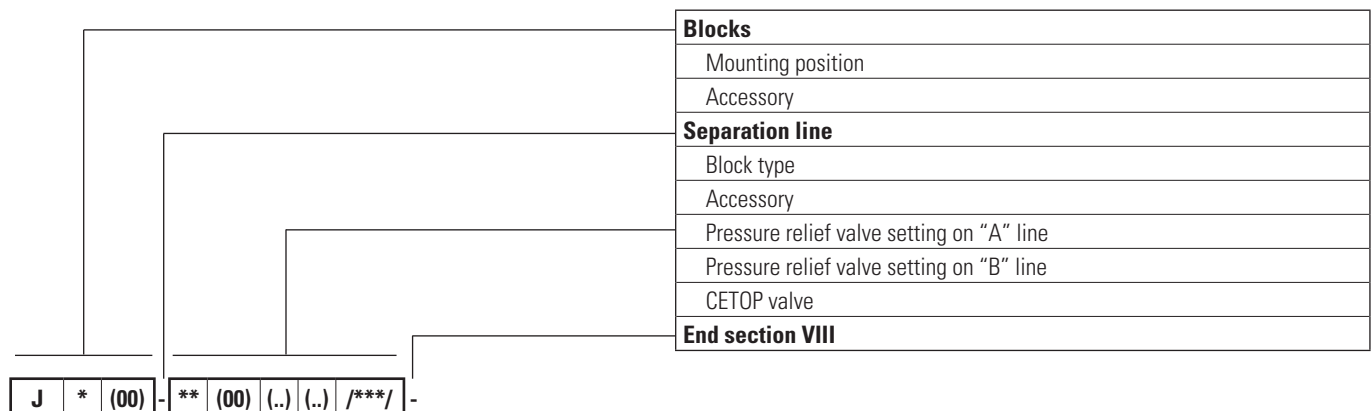

SECTION IX - ACCESSORIES

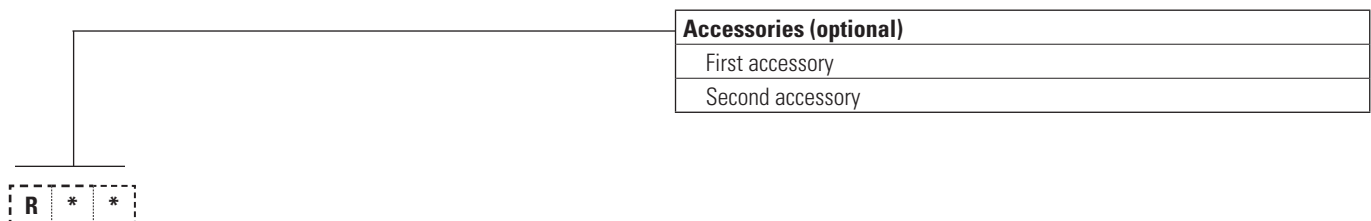

Cavities dimensions

i

Cavity		Thread	Drawing
1	Peripheral	M18 x 1.5	<p>CN037004</p>
1R	Peripheral	M16 x 1.5	<p>CN041007</p>
2	Peripheral	3/4 16 UNF	<p>3A</p>
3 MCA	Peripheral	M20 x 1.5	<p>1C</p>
3 MCB	Peripheral	M20 x 1.5	<p>1P</p>

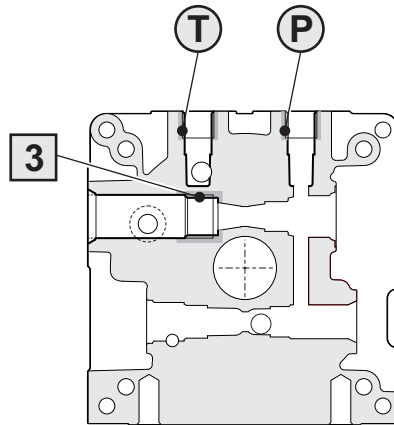
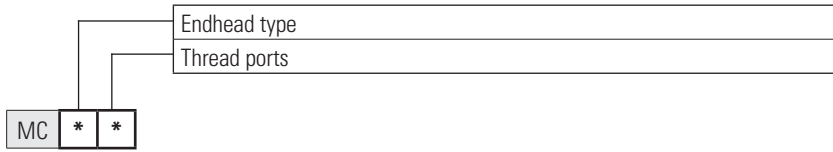

The machining of the **cavity 3** and the **P-T** ports define the body type.

***** *Endhead type*

*	Description
A	For manual controls, flow regulators, logic valves on cavity 3 (Old commercial description MC)
B	For flow regulator VSC06 (3/8" BSP) on cavity 3 (Old commercial description MS)

***** *Thread ports P-T"*

*	Ports thread				Blocks interface
	G1/4"	G3/8"	9/16" 18 UNF	7/16" 20 UNF	
0	YES				YES
1		YES			NO
2			YES		NO
3				YES	NO

	Endhead codes			
	G1/4"	G3/8"	7/16" 20 UNF	9/16" 18 UNF
MCA	71013000.000	71013001.000	—	71013022.000
MCB	71013003.000	71013005.000	71013007.000	—

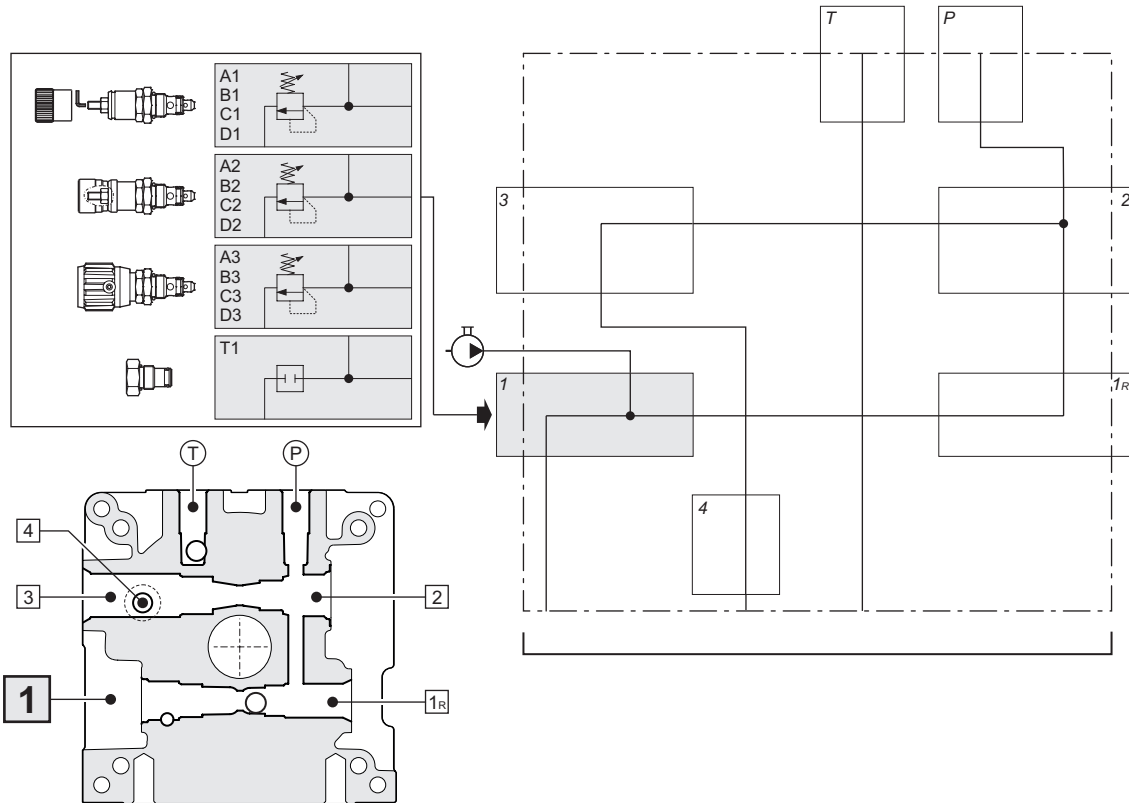
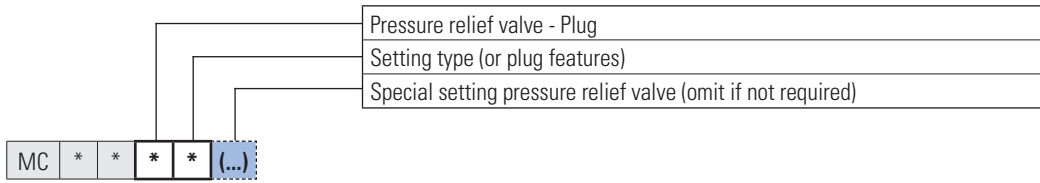

*** * (...)** *Pressure relief valve direct-acting*

* *	Pressure (bar)	STD setting (bar)	(...) Special setting (bar)	Setting type	Code	Symbol	Drawing
A	15 ÷ 50	30	15 ÷ 50 (5 to 5)	Detachable closing	CPMC04S0001		
				Non removable closing (1)	CPMC04P0001		
				Plastic knob	CPMC04M0001		
B	35 ÷ 110	50	35 ÷ 110 (5 to 5)	Detachable closing	CPMC04S1001		
				Non removable closing (1)	CPMC04P1001		
				Plastic knob	CPMC04M1001		
C	75 ÷ 220	150	75 ÷ 220 (5 to 5)	Detachable closing	CPMC04S2001		
				Non removable closing (1)	CPMC04P2001		
				Plastic knob	CPMC04M2001		
D	160 ÷ 290	180	160 ÷ 290 (10 to 10)	Detachable closing	CPMC04S3001		
				Non removable closing (1)	CPMC04P3001		
				Plastic knob	CPMC04M3001		

1 = Supplied assembled. Unassembled, see accessories page 59

*** * Plug**

* *	Description	Code	Symbol	Drawing
T 1	Closed plug to replace pressure relief valve	20001600		

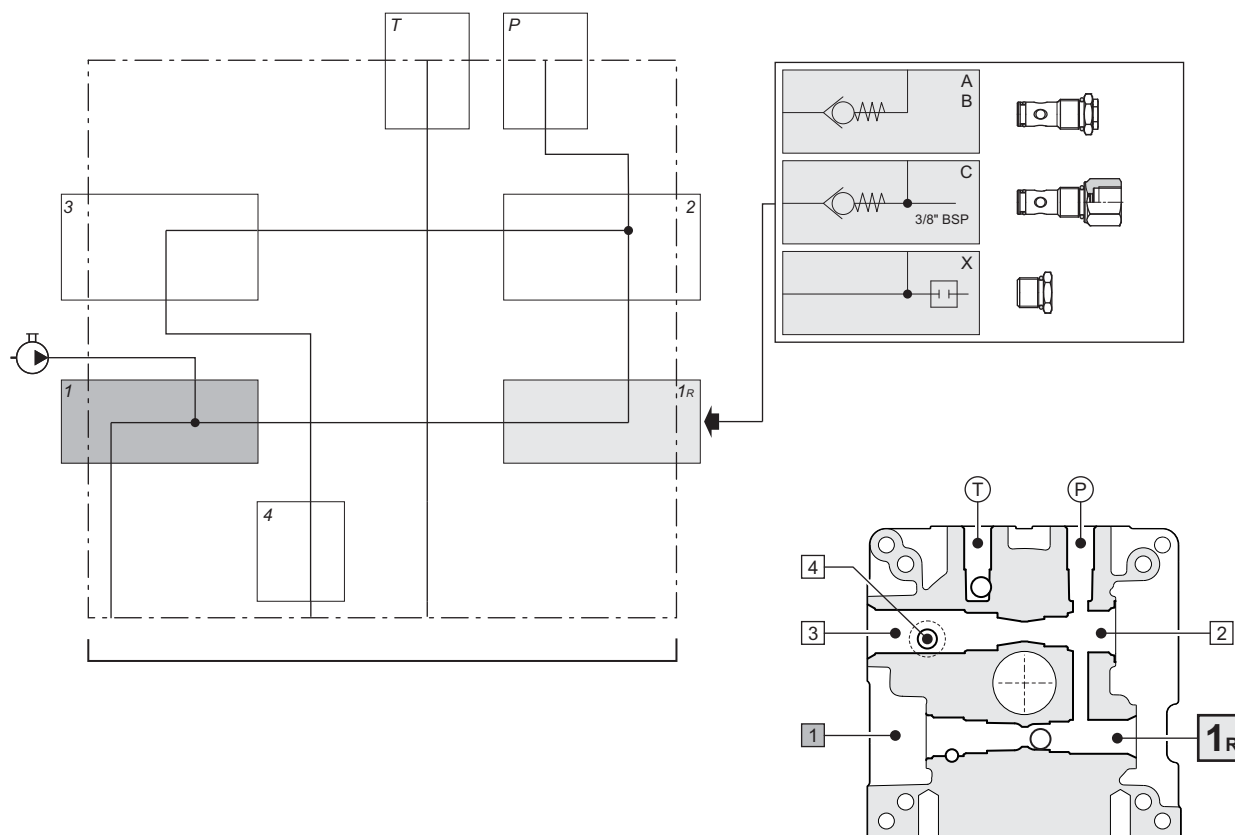
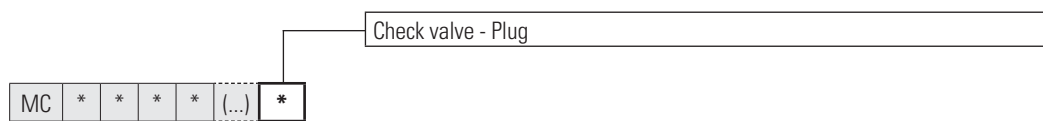

*** Check valve**

* Description	Code	Symbol	Drawing
A Standard	20020400		
B Pre-setting 2 bar	20012000		
C With outlet 3/8" BSP	20023900		



*** Plug**

* Description	Code	Symbol	Drawing
X Plug to replace check valve	20006100		

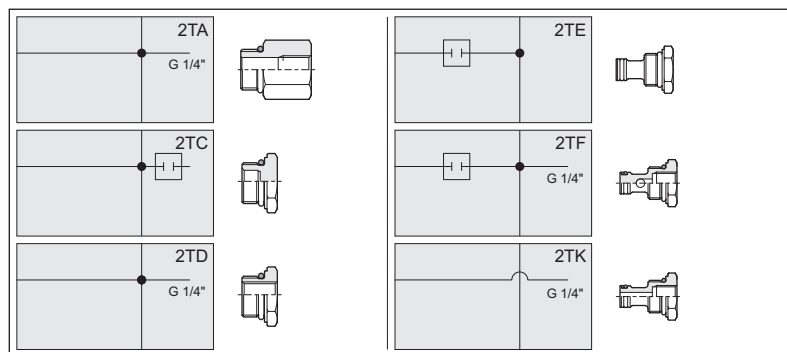
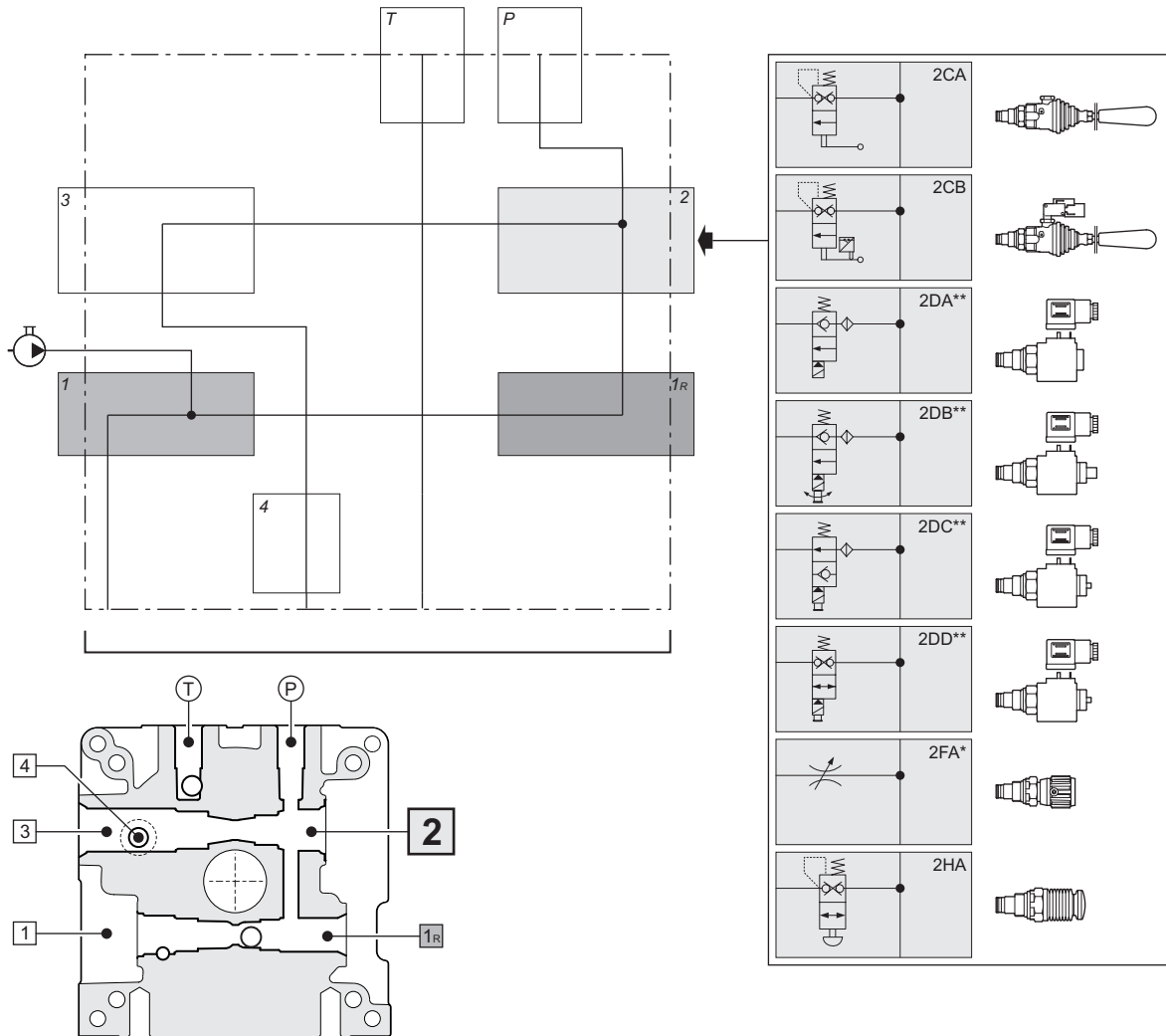
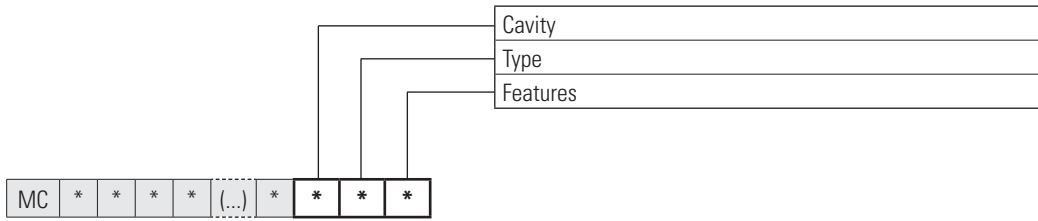

Sect. II - MC Cavity 2



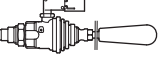

2 C * *Lever operated valve*

*	Description	Code	Symbol	Drawing
A	Without microswitch	CMF04L001		
B	With microswitch	CMF04M001		



2 DA ** *Piloted solenoid valves normally closed, without emergency (1)*

**	Description	Code (valve + connector)	Symbol	Drawing
AA	Voltage 12 Vdc	CRP0418NCASL003 + V86050002		
AB	Voltage 24 Vdc	CRP0418NCASM003 + V86050002		
AC	Voltage 24 Vac 50 Hz	CRP0418NCASA003 + V86050002		
AD	Voltage 115 Vac 50 Hz	CRP0418NCASJ003 + V86050002		
AE	Voltage 230 Vac 50 Hz	CRP0418NCASI003 + V86050002		



2 DB ** *Piloted solenoid valves normally open, with rotary emergency (1)*

**	Description	Code (valve + connector)	Symbol	Drawing
AA	Voltage 12 Vdc	CRP0418NCAEL003 + V86050002		
AB	Voltage 24 Vdc	CRP0418NCAEM003 + V86050002		
AC	Voltage 24 Vac 50 Hz	CRP0418NCAEA003 + V86050002		
AD	Voltage 115 Vac 50 Hz	CRP0418NCAEJ003 + V86050002		
AE	Voltage 230 Vac 50 Hz	CRP0418NCAEI003 + V86050002		

2 DC ** *Piloted solenoid valves normally open, with button emergency (1)*



**	Description	Code (valve + connector)	Symbol	Drawing
AA	Voltage 12 Vdc	CRP0418NAAEL003 + V86050002		
AB	Voltage 24 Vdc	CRP0418NAAEM003 + V86050002		
AC	Voltage 24 Vac 50/60 Hz (RAC with rectifier)	CRP0418NAAE2003 + V86200002		
AD	Voltage 115 Vac 50 - 120 Vac 60 Hz (RAC with rectifier)	CRP0418NAAEZ003 + V86200002		
AE	Voltage 230 Vac 50 - 240 Vac 60 Hz (RAC with rectifier)	CRP0418NAAEX003 + V86200002		
AF	Voltage 48 Vdc	CRP0418NAAEN003 + V86050002		

2 DD ** *Direct operated solenoid valve normally closed, with button emergency (1)*



**	Description	Code (valve + connector)	Symbol	Drawing
AA	Voltage 12 Vdc	CRD0418NCAEL002 + V86050002		
AB	Voltage 24 Vdc	CRD0418NCAEM002 + V86050002		

1 = Valves supplied with connector. Without connector see accessories page 59













2 FA * *Bidirectional flow control valves not compensated*

* Description	Code	Symbol	Drawing
A Screw adjustment	CSB04C0000		
B Plastic knob adjustment	CSB04V0000		

2 H * *Button operated valves*

** Description	Code	Symbol	Drawing
A Push-button control	CPE04P000.1		

2 T * *Plugs and fittings*

* Description	Code	Symbol	Drawing
A Fitting 3/4 16 UNF - G1/4	20012100		
C Plug 3/4 16 UNF	R78150099		
D Fitting 3/4 16 UNF - G1/4	20001700		
E Long plug 3/4 16 UNF	20003800		
F Fitting 3/4 16 UNF - G1/4	20009400		
K Fitting 3/4 16 UNF DIN - G1/4	20018000		

Sect. II - MCA Cavity 3

Cavity
Type
Features



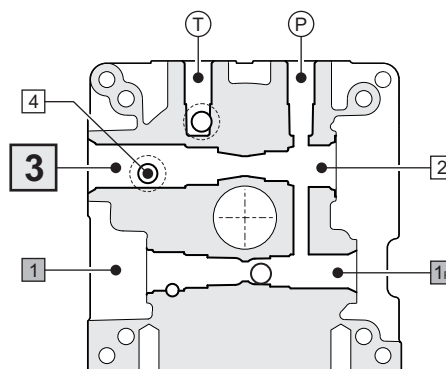
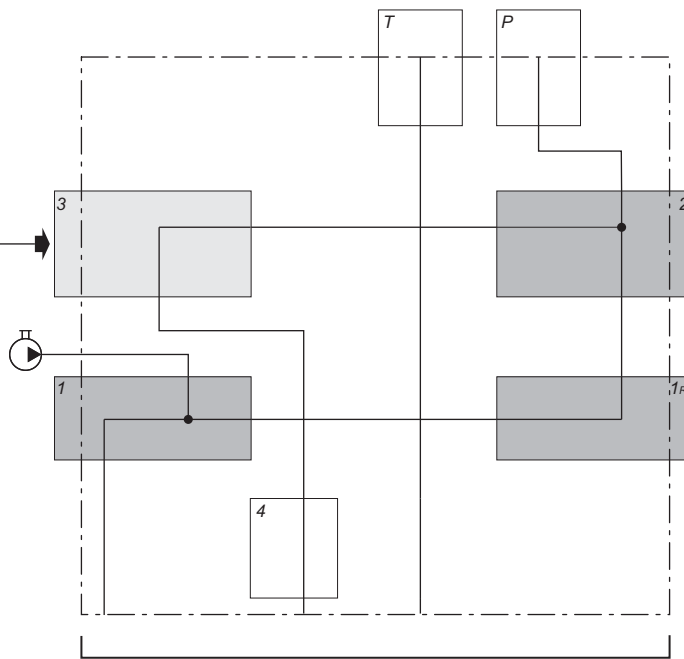
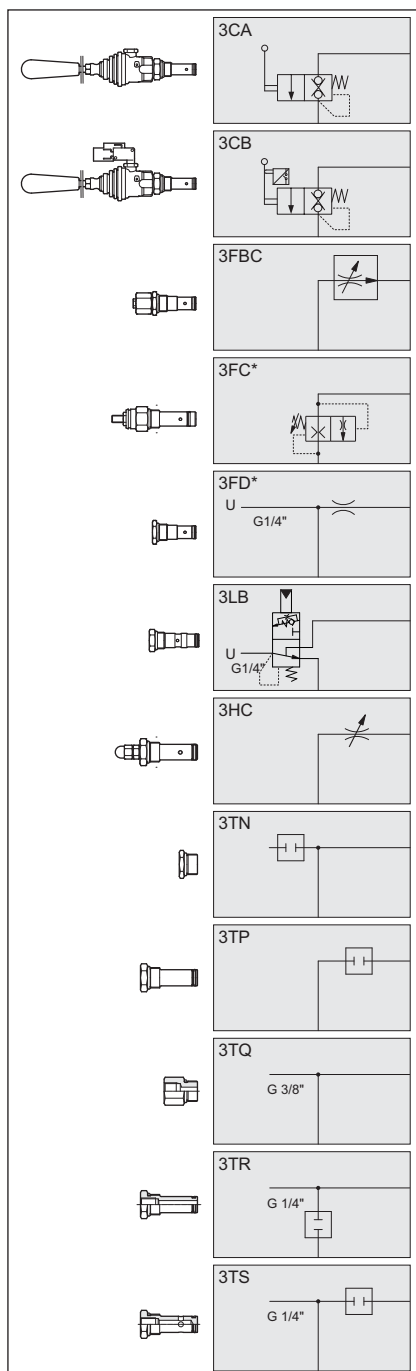

Components only for MCA

MC **A** * * * * (...) * * * * * * * *



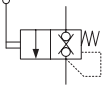

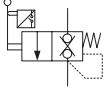
II
MCA



3 C * Lever operated valve

* Description	Code	Symbol	Drawing
A Without microswitch	CMT044L0001		
B With microswitch	CMT044M0001		



3 FB * Adjustable unidirectional flow control valve compensated

* Description	Setting	Code	Symbol	Drawing
C Screw adjustment	0.5 ÷ 22 l/min	21000020.000		



3 FC * Adjustable flow control valve compensated (type VRFE)

* Description	Setting	Code	Symbol	Drawing
A B C Screw adjustment	2 ÷ 3,5 l/min	20019800		
	5 ÷ 7,5 l/min	20019900		
	8,5 ÷ 13,5 l/min	20020000		

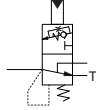

3 FD * Flow control valve

* Description	Ø hole	Code	Symbol	Drawing
A B C With G 1/4"	0,7 mm	20020300		 G1/4"
	0,9 mm	20017500		
	1 mm	20014400		

3 LB * Logic valve with chek valve











* Description	Code	Symbol	Drawing
A Out G 1/4"	20024100		 G1/4"

3 H * Flow control valve not compensated

* Description	Code	Symbol	Drawing
C Screw adjustment	20003900		

Sect. II - MCA Cavity 3

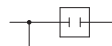
3 T * *Plugs and fittings*

*	Description	Code	Symbol	Drawing
N	Plug	20002200		
P	Long plug	20001100		
Q	Fitting G3/8"	20022800		G3/8" 
R	Long fitting G1/4"	20007900		G1/4" 
S	Return line fitting G1/4"	20001400		G1/4" 

II
MCA

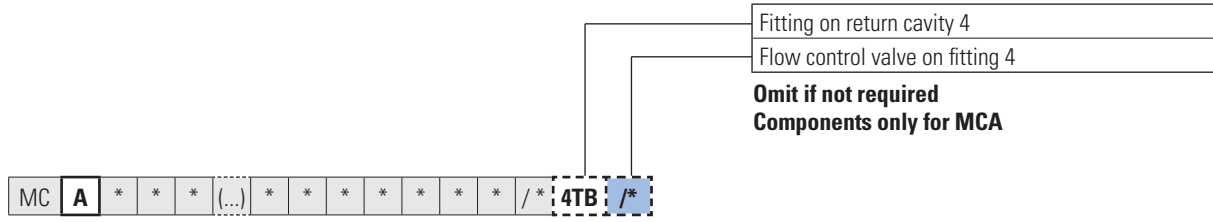

Componenti solo per MCA

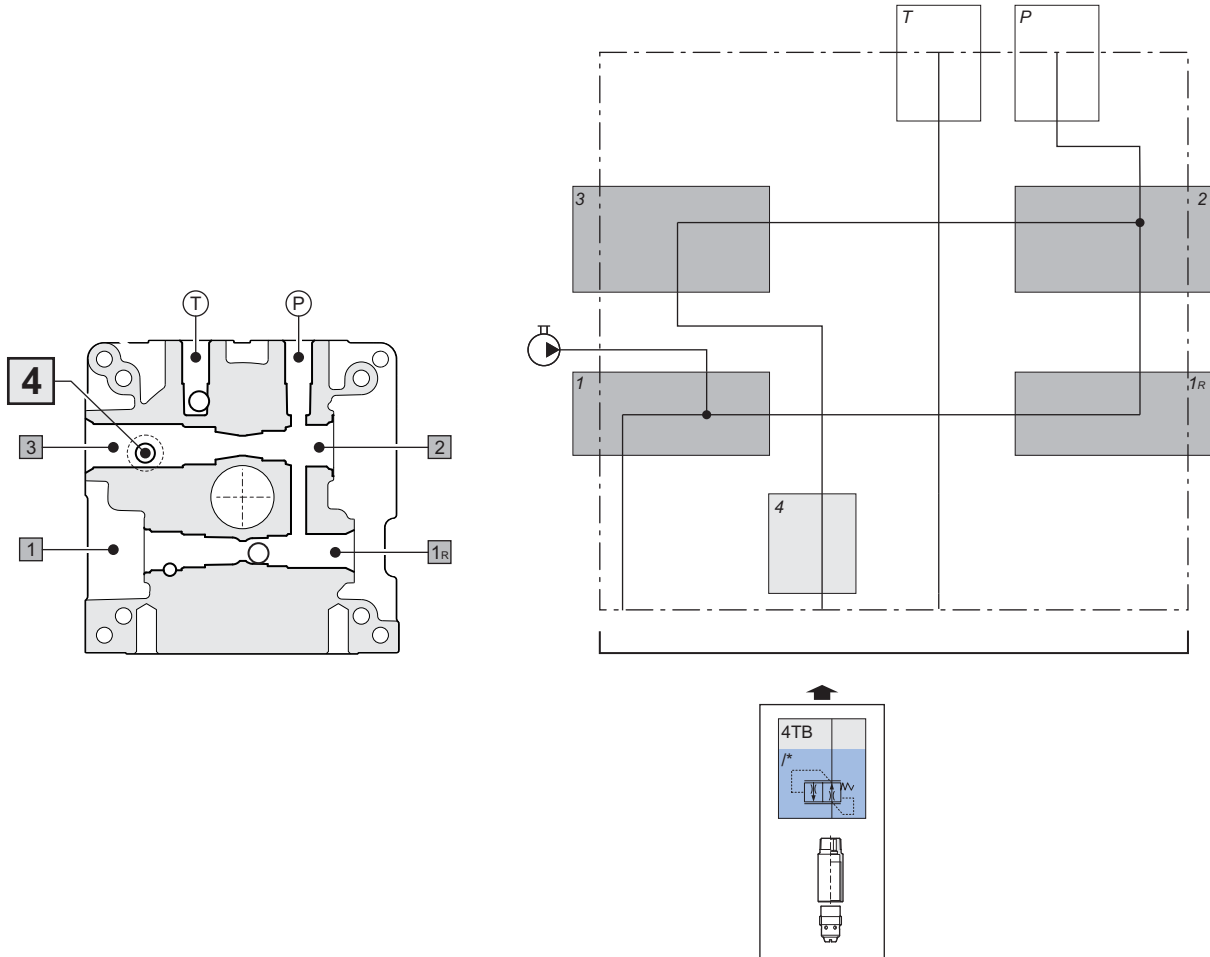

Any fitting and flow control valve on cavity 4

4 TB /* *Fitting and flow control valve*

/*	Flow	Code (flow control valve)	Code (fitting for flow control valve)	Simbol	Drawing
/A	0.7 l/min	VSC06100002	M67250053		
/B	1.1 l/min	VSC06120002			
/C	2.1 l/min	VSC06130002			
/E	3.2 l/min	VSC06150002			
/G	4.7 l/min	VSC06190002			
/K	6.3 l/min	VSC06220002			
/N	7.5 l/min	VSC06240002			
/Q	10.0 l/min	VSC06280002			
/U	13.2 l/min	VSC06330002			
/V	15.7 l/min	VSC06350002			

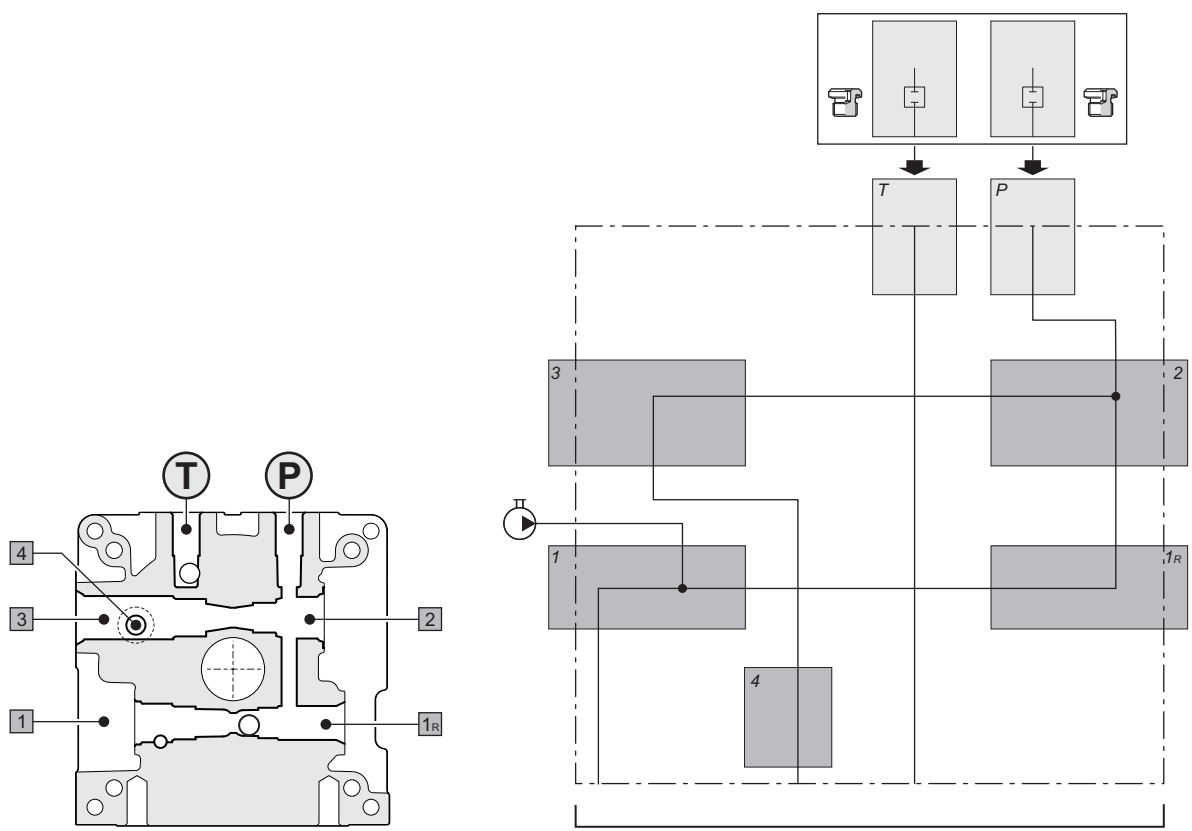
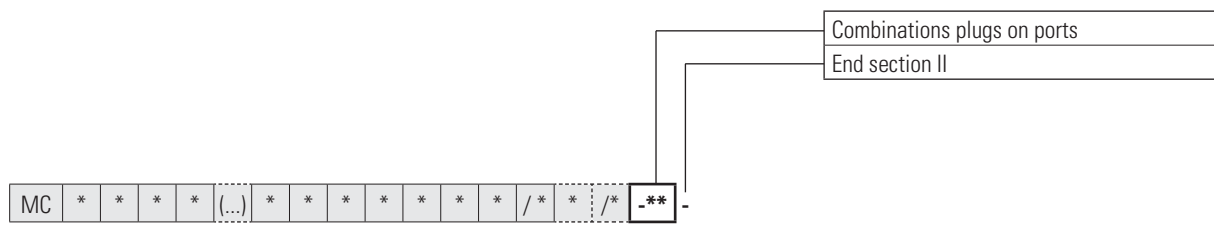

-** Combinations plugs on ports P-T

-**	P	T
-00	↑	↑
-02	⊗	↑
-03	↑	⊗
-06	⊗	⊗

Symbols description

Type	Description	Thread	Code	Symbol	Drawing
⊗	Port closed with plug	G 1/4"	20024000		
		G 3/8"	Q26622255 (plug) + Q51435044 (washer)		
		7/16" 20 UNF	TJ08072000		
		9/16" 18 UNF	TJ08091800		
↑	Port open		—	—	—

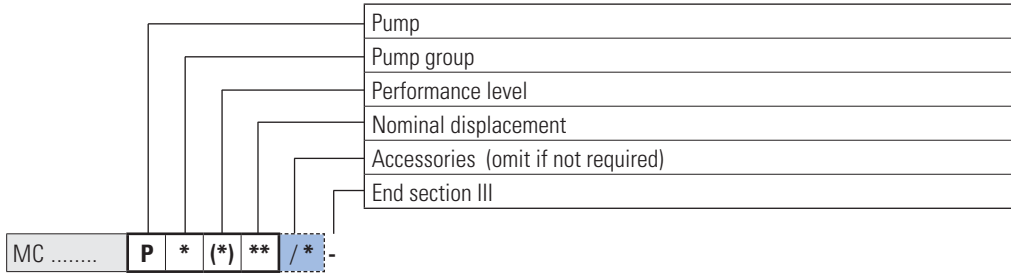

P 0 (1) ** **Pumps group 05 - Performance level 1**

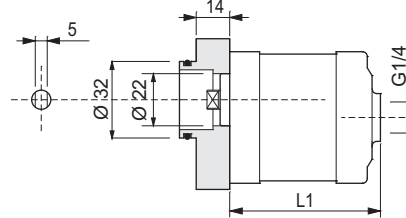

**	Nominal displacement	Tolerance on geometric displacement	P2 bar	P3 bar	Code complete kit	L1 mm	Tanks not compatible (•)				Motors not compatible
							S01A	S09E	S02G	All	
							(H) (V)	(H) (V)	(H) (V)	(H) (V)	
02	0.25 cc	0.25 ÷ 0.33	230	270	17050037.035	54					M4FB(1) - M4GJ(1) MM*PA(1) M*AA(1)D - M*AA(1)G M*AA(1)H M*AB(1)D - M*AB(1)G M*AB(1)H
04	0.45 cc	0.45 ÷ 0.55	230	270	17050036.035	55.7					
05	0.56 cc	0.56 ÷ 0.68	230	270	17050039.035	56.7		•	•		
07	0.75 cc	0.69 ÷ 0.82	230	270	17050038.035	58.5		•	•		
09	0.92 cc	0.83 ÷ 0.95	230	270	17050053.035	59.8		•	•		

P2 = Intermittent operating pressure
 P3 = Intermittent peak pressure (20 sec. max)

Tanks not compatible (as dimensions, see page 25)
 Motors not compatible (interface and transmission not supplied, see pages 41 - 47)

P 1 (1) ** **Pumps group 1 - Performance level 1**

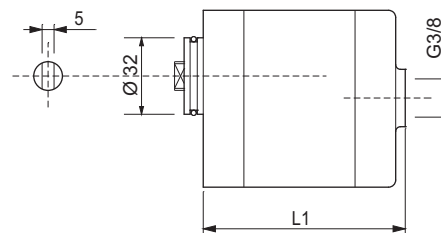

**	Nominal displacement	Tolerance on geometric displacement	P2 bar	P3 bar	Code complete kit	L1 mm	Tanks not compatible (•)				
							S01A	S09E	S02G	All	
							(H) (V)	(H) (V)	(H) (V)	(H) (V)	
07	0.80 cc	0.69 ÷ 0.82	170	210	17050107.018	72.4		•			
10	1.00 cc	0.96 ÷ 1.09	170	210	17050088.018	73.5		•			
12	1.20 cc	1.10 ÷ 1.30	250	290	17050005.018	74.8		•			
17	1.70 cc	1.50 ÷ 1.70	250	290	17050006.018	76.2		•			
22	2.20 cc	2.10 ÷ 2.30	250	290	17050007.018	78.2		•			
26	2.60 cc	2.50 ÷ 2.70	250	290	17050008.018	79.7		•	•		
32	3.20 cc	3.10 ÷ 3.32	250	290	17050009.018	82.0		•	•		
38	3.80 cc	3.60 ÷ 3.99	250	290	17050010.018	84.0		•	•		
43	4.30 cc	4.00 ÷ 4.35	250	290	17050011.018	86.6		•	•		
48	4.80 cc	4.85 ÷ 4.95	225	260	17050033.018	88.1		•	•		
60	6.00 cc	5.62 ÷ 6.02	185	215	17050012.018	92.2	•	•	•	•	
78	7.80 cc	7.48 ÷ 7.90	140	160	17050013.018	98.9	•	•	•	•	
98	9.80 cc	9.60 ÷ 10.00	110	125	17050054.018	107.2	•	•	•	•	

P2 = Intermittent operating pressure
 P3 = Intermittent peak pressure (20 sec. max)

Tanks not compatible (as dimensions, see page 25).

P 1 (1) ** / * **Accessories for pumps group 1**

Displacement

*	Description	Type	Code	Symbol
/A	Single-phase motor start valve - on auxiliary outlet	0.8 ÷ 2.5 l/min	VAM0400L	
/B		> 2.5 ÷ 8.0 l/min	VAM0400M	
/C		> 8.0 ÷ 14 l/min	VAM0400H	
/D	Soft start valve - on auxiliary outlet	hole Ø 0.4 mm	VAMS0404001	

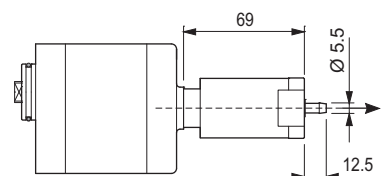
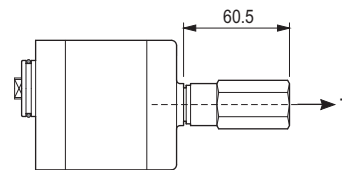

**	With accessory	Tanks not compatible (•)			
		S01A	S09E	S02G	All
09	/A /B /C				
	/D	•	•	•	
12	/A /B /C				
	/D	•	•	•	
17	/A /B /C				
	/D	•	•	•	
22	/A /B /C				
	/D	•	•	•	
26	/A /B /C				
	/D	•	•	•	
32	/A /B /C				
	/D	•	•	•	
38	/A /B /C				
	/D	•	•	•	
43	/A /B /C				
	/D	•	•	•	

Tanks not compatible (as dimensions, see page 25).

Sect. IV - Tanks / Sect. V - Tubes kit

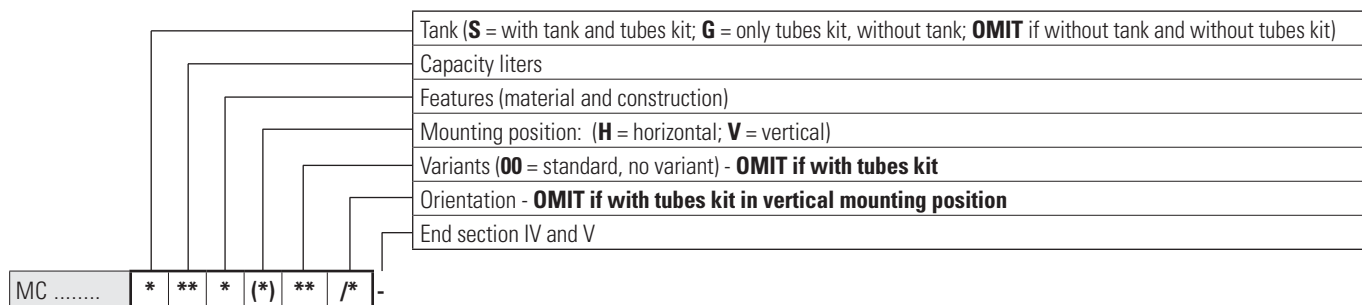

**	Liters	*	Dimensions (mm)	Material	(*) Mounting	** Variants	Page	*	Page
01	1	A	∅ 123 - L 141	Sheet steel	(H)	00	26	/1(std) /2 /3 /4	39
					(V)	00			
02	1,5	G	∅ 130x140 - L 135	Polyethylene	(H)	00	35		
					(V)	00			
02	2	A	∅ 123 - L 200	Sheet steel	(H)	00	26		
					(V)	00			
03	2,5	G	∅ 130x140 - L 235	Polyethylene	(H)	00	35		
					(V)	00			
03	3	A	∅ 123 - L 330	Sheet steel	(H)	00	26		
					(V)	00			
04	4	G	∅ 130x140 - L 295	Polyethylene	(H)	00	35		
					(V)	00			
04	4	L	∅ 180 - L 210	Polyethylene	(H)	00	36		
					(V)	00			
05	5	B	∅ 175 - L 246	Sheet steel	(H)	00-01-02-03-04	27		
					(V)	00			
05	5	C	∅ 200 - L 210	Sheet steel	(H)	00	28		
					(V)	00			
05	5	F	∅ 180 - L 240	Polypropylene	(H)	00	34		
					(V)	00			
06	6	B	∅ 175 - L 308	Sheet steel	(H)	00-04	27		
					(V)	00			
07	7	E	∅ 154x188 - L 299	Sheet steel	(V)	00-01	30		
					(H)	00			
07	7	F	∅ 180 - L 308	Polypropylene	(V)	00	34		
					(H)	00			
07	7	L	∅ 180 - L 310	Polyethylene	(H)	00	37		
					(V)	00			
07	7	M	∅ 180 - L 335	Polietilene	(H)	00	38		
					(V)	00			
08	8	B	∅ 175 - L 370	Sheet steel	(H)	00-04	27		
					(V)	00			
08	8	C	∅ 200 - L 306	Sheet steel	(H)	00	28		
					(V)	00			
09	9	E	∅ 230x130 - L 350	Sheet steel	(H)	00	31		
					(V)	00			
09	9	L	∅ 180 - L 370	Polietilene	(V)	00	37		
					(H)	00			
10	10	C	∅ 200 - L 373	Sheet steel	(H)	00	28		
					(V)	00			
10	10	D	∅ 217 - L 273	Sheet steel	(H)	00	29		
					(V)	00			
10	10	L	∅ 180 - L 410	Polyethylene	(H)	00	37		
					(V)	00			
12	12	D	∅ 217 - L 370	Sheet steel	(H)	00	29		
					(V)	00			
14	14	E	∅ 255x193 - L 366	Sheet steel	(V)	00-01	32		
					(H)	00-01			
25	25	E	∅ 250x255 - L 436	Sheet steel	(H)	00-01	33		
					(V)	00-01			

IV
V

Sect. IV - Tanks / Sect. V - Tubes kit

* ** * (H) ** * - Tanks Ø 123 - Sheet steel, capacity 1-2-3 liters - Horizontal mounting (black painted)

Capacity	Features	Mounting	Variant (1)	L (mm)	Capacity (liters)			Tank (with plug)	Tank fixing kit (screws and O-Ring)
					Nominal	Full	Usable		
01				141	1	1.0	0.7	90310000	17010086
02	A	(H)	00	200	2	1.6	1.5	90310001	
03				330	3	3	2.8	90310002	

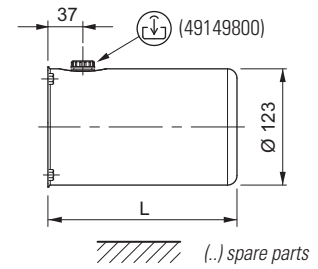

(1) Variant - OMIT if without tank but with tubes kit

Other variants

Variant	Tank	Variant	Tank	Variant	Tank	Variant	Tank

IV
V

* ** * (V) ** * - Tanks Ø 123 - Sheet steel, capacity 1-2-3 liters - Vertical mounting (black painted)

Capacity	Features	Mounting	Variant (1)	L (mm)	Capacity (liters)			Tank (with plug)	Tank fixing kit (screws and O-Ring)
					Nominal	Full	Usable		
01				141	1	0.9	0.7	90310009	17010086
02	A	(V)	00	200	2	1.6	1.5	90310010	
03				330	3	2.9	2.9	90310011	

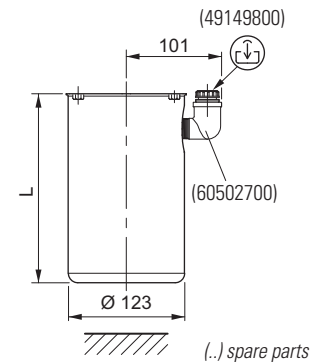

(1) Variant - OMIT if without tank but with tubes kit

Other variants

Variant	Tank	Variant	Tank	Variant	Tank	Variant	Tank

Sect. IV - Tanks / Sect. V - Tubes kit

* ** * (H) ** * - Tanks Ø 175 - Sheet steel, capacity 5-6-8 liters - Horizontal mounting (black painted)

Capacity	Features	Mounting	Variant (1)	L (mm)	Capacity (liters)			Tank (with plugs)	Tank fixing kit (screws and O-Ring)
					Nominal	Full	Usable		
05				246	5	4.7	4.5	90310003	17010086
06	B	(H)	00	308	6	6	5.9	90310004	
08				370	8	8	7.3	90310005	

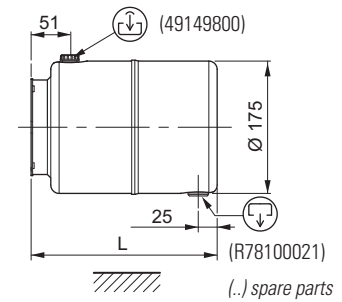

(1) Variant - OMIT if without tank but with tubes kit

Other variants

Variant				Tank	Variant				Tank	Variant				Tank
05				90310003	05				90310149	05				90310134
06	B	(H)	01		06	B	(H)	02		06	B	(H)	03	90310062
08					08					08				90310069
				(49149800)					(60306400)					(49107500)
				(R78100021)					(R78100021)					(R78100021)
				(49121900)					(R78100021)					(R78100021)

IV
V

* ** * (V) ** * - Tanks Ø 175 - Sheet steel, capacity 5-6-8 liters - Vertical mounting (black painted)

Capacity	Features	Mounting	Variant (1)	L (mm)	Capacity (liters)			Tank (with plugs)	Tank fixing kit (screws and O-Ring)
					Nominal	Full	Usable		
05				246	5	4.3	4.1	90310012	17010086
06	B	(V)	00	308	6	5.8	5.5	90310013	
08				370	8	7.5	7.2	90310015	

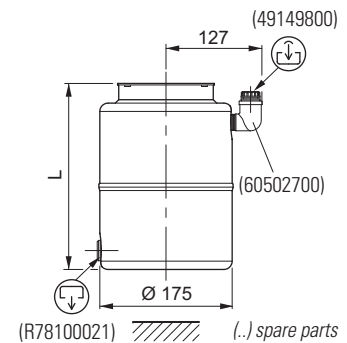

(1) Variant - OMIT if without tank but with tubes kit

Other variants

Variant				Tank	Variant				Tank	Variant				Tank

Sect. IV - Tanks / Sect. V - Tubes kit

* ** * (H) ** * - Tanks Ø 200 - Sheet steel, capacity 5-8-10 liters - Horizontal mounting (black painted)

Capacity	Features	Mounting	Variant (1)	L (mm)	Capacity (liters)			Tank (with plugs)	Tank fixing kit (screws and O-Ring)
					Nominal	Full	Usable		
05				205	5	5.3	5.0	90310425	17010086
08	C	(H)	00	301	8	8.0	7.7	90310428	
10				368	10	10	9.3	90310431	

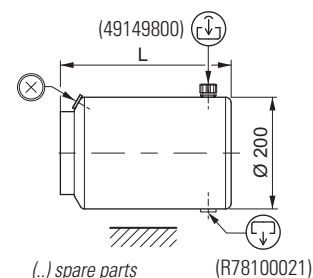

(1) Variant - OMIT if without tank but with tubes kit

Other variants

Variant	Tank	Variant	Tank	Variant	Tank	Variant	Tank
				05	90310453		
				08	90310443	C (H) 03	
				10	90310483		

* ** * (V) ** * - Tanks Ø 200 - Sheet steel, capacity 5-8-10 liters - Vertical mounting (black painted)

Capacity	Features	Mounting	Variant (1)	L (mm)	Capacity (liters)			Tank (with plugs)	Tank fixing kit (screws and O-Ring)
					Nominal	Full	Usable		
05				205	5	4.6	4.3	90310444	17010086
08	C	(V)	00	301	8	7.5	7.1	90310437	
10				368	10	9.5	9.1	90310439	

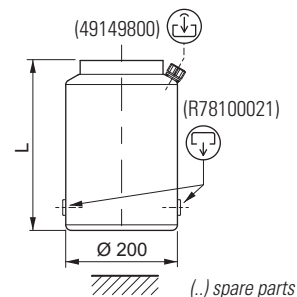

(1) Variant - OMIT if without tank but with tubes kit

Other variants

Variant	Tank	Variant	Tank	Variant	Tank	Variant	Tank

Sect. IV - Tanks / Sect. V - Tubes kit

* ** * (H) ** * - Tanks Ø 217 - Sheet steel, capacity 10-12 liters - Horizontal mounting (black painted)

Capacity	Features	Mounting	Variant (1)	L (mm)	Capacity (liters)			Tank (with plugs)	Tank fixing kit (screws and O-Ring)
					Nominal	Full	Usable		
10	D (H) 00			273	10	8	7.6	90310006	17010086
12				370	12	12	11	90310058	

(1) Variant - OMIT if without tank but with tubes kit

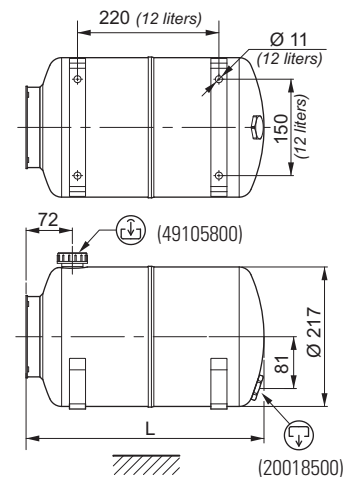

Other variants

(..) spare parts

Variant	Tank	Variant	Tank	Variant	Tank	Variant	Tank

IV
V

* ** * (V) ** * - Tanks Ø 217 - Sheet steel, capacity 10-12 liters - Vertical mounting (black painted)

Capacity	Features	Mounting	Variant (1)	L (mm)	Capacity (liters)			Tank (with plugs)	Tank fixing kit (screws and O-Ring)
					Nominal	Full	Usable		
10	D (V) 00			273	10	7	6.8	90310029	17010086
12				370	12	10.3	10.1	90310100	

(1) Variant - OMIT if without tank but with tubes kit

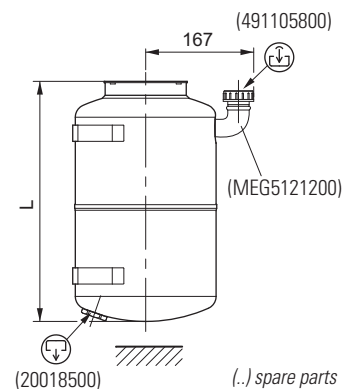

Other variants

Variant	Tank	Variant	Tank	Variant	Tank	Variant	Tank

Sect. IV - Tanks / Sect. V - Tubes kit

* ** * (V) ** * - Rectangular tanks - Sheet steel, capacity 7 liters - Vertical mounting (black painted)

Capacity	Features	Mounting	Variant (1)	L (mm)	Capacity (liters)			Tank (with plugs)	Tank fixing kit (screws and O-Ring)
					Nominal	Full	Usable		
07	E	(V)	00	299	7	5.5	5.1	90310014	17010086

(1) Variant - OMIT if without tank but with tubes kit

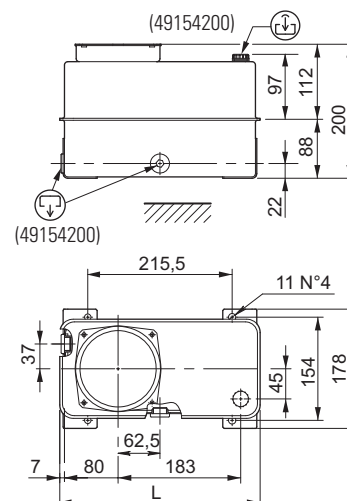

(..) spare parts

Other variants

Variant				Tank				Variant				Tank				Variant				Tank																		
07	E	(V)	01	90310036																																		

IV
V

Sect. IV - Tanks / Sect. V - Tubes kit

* ** * (H) ** * - **Rectangular tanks - Sheet steel, capacity 9 liters - Horizontal mounting (black painted)**

Capacity	Features	Mounting	Variant (1)	L (mm)	Capacity (liters)			Tank (with plugs)	Tank fixing kit (screws and O-Ring)
					Nominal	Full	Usable		
09	E	(H)	00	350	9	9	8	90310142	17010086

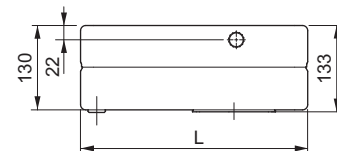
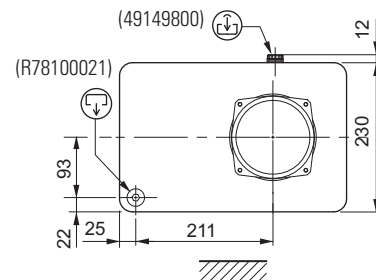

(1) Variant - OMIT if without tank but with tubes kit

(..) spare parts

Other variants

Variant	Tank	Variant	Tank	Variant	Tank	Variant	Tank

**IV
V**

* ** * (V) ** * - **Rectangular tanks - Sheet steel, capacity 9 liters - Vertical mounting (black painted)**

Capacity	Features	Mounting	Variant (1)	L (mm)	Capacity (liters)			Tank (with plugs)	Tank fixing kit (screws and O-Ring)
					Nominal	Full	Usable		
09	E	(V)	00	350	9	8.6	7.5	90310142	17010086

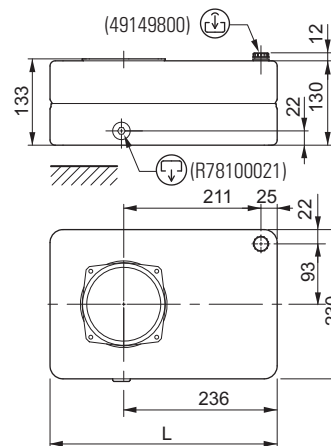

(1) Variant - OMIT if without tank but with tubes kit

(..) spare parts

Other variants

Variant	Tank	Variant	Tank	Variant	Tank	Variant	Tank

Sect. IV - Tanks / Sect. V - Tubes kit

* ** * (*) ** * - Rectangular tanks - Sheet steel, capacity 14 liters - Vertical mounting (black painted)

Capacity	Features	Mounting	Variant (1)	L (mm)	Capacity (liters)			Tank (with plugs)	Tank fixing kit (screws and O-Ring)
					Nominal	Full	Usable		
14	E	(V)	00	366	14	14	13	90310045	17010086

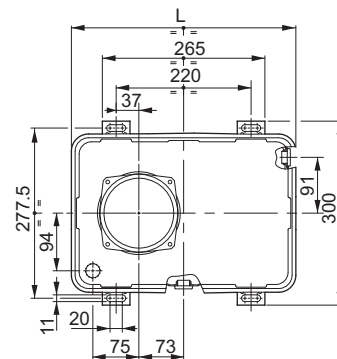
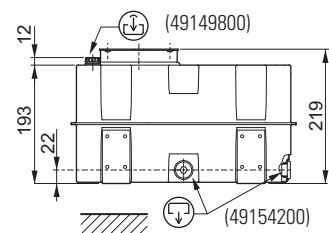

(1) Variant - OMIT if without tank but with tubes kit

(..) spare parts

Other variants

Variant				Tank			
14	E	(V)	01	90310046			

IV
V

Sect. IV - Tanks / Sect. V - Tubes kit

* ** * (*) ** * - **Rectangular tanks - Sheet steel, capacity 25 liters - Horizontal mounting (black painted)**

Capacity	Features	Mounting	Variant (1)	L (mm)	Capacity (liters)			Tank (with plugs)	Tank fixing kit (screws and O-Ring)
					Nominal	Full	Usable		
25	E	(H)	00	436	25	22	21	90310060	17010086

(1) Variant - OMIT if without tank but with tubes kit

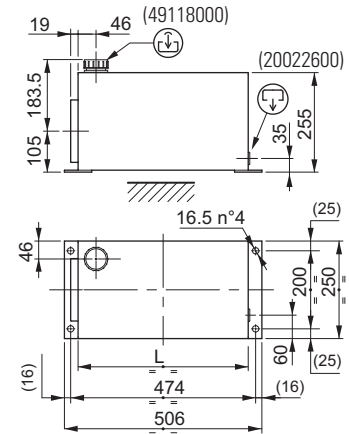

(..) spare parts

Other variants

Variant	Tank	Variant	Tank	Variant	Tank	Variant	Tank
25 E (H) 01	90310083						

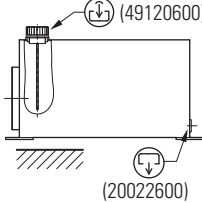

IV
V

* ** * (*) ** * - **Rectangular tanks - Sheet steel, capacity 25 liters - Vertical mounting (black painted)**

Capacity	Features	Mounting	Variant (1)	L (mm)	Capacity (liters)			Tank (with plugs)	Tank fixing kit (screws and O-Ring)
					Nominal	Full	Usable		
25	E	(V)	00	436	25	25	22	90310071	17010086

(1) Variant - OMIT if without tank but with tubes kit

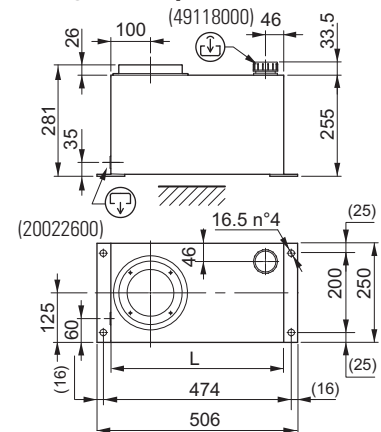

(..) spare parts

Other variants

Variant	Tank	Variant	Tank	Variant	Tank	Variant	Tank
25 E (V) 01	90310124						

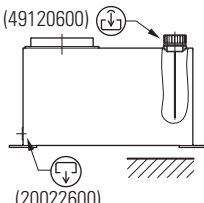

* ** * (H) ** * - **Square polypropylene tanks capacity 5-7 liters - Horizontal mounting**

Capacity	Features	Mounting	Variant (1)	L (mm)	Capacity (liters)			Tank (with plug, brackets, nuts)	Tank fixing kit (screws and O-Ring)
					Nominal	Full	Usable		
05	F (H) 00			242	5	5.4	4.5	90310313	17010086
07				308	7	7.4	6.5	90310289	

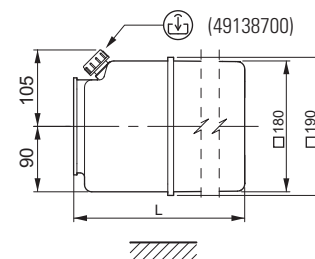

Operating temperature -10°C ÷ +60°C - (1) Variant - OMIT if without tank but with tubes kit

(..) spare parts

IV V

* ** * (V) ** * - **Square polypropylene tanks capacity 5-7 liters - Vertical mounting**

Capacity	Features	Mounting	Variant (1)	L (mm)	Capacity (liters)			Tank (with plug, brackets, nuts)	Tank fixing kit (screws and O-Ring)
					Nominal	Full	Usable		
05	F (V) 00			242	5	5.4	4.5	90310313	17010086
07				306	7	7.4	6.5	90310289	

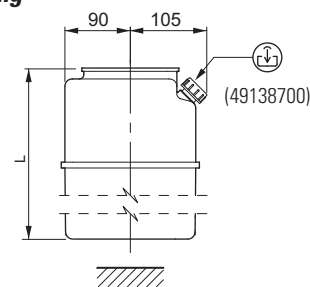

Operating temperature -10°C ÷ +60°C - (1) Variant - OMIT if without tank but with tubes kit

(..) spare parts

Sect. IV - Tanks / Sect. V - Tubes kit

* ** * (H) ** * - **Square polyethylene tanks capacity 1.5-2.5-4 liters - Horizontal mounting**

Capacity	Features	Mounting	Variant (1)	L (mm)	Capacity (liters)			Tank (with plugs, clamp, nuts)	Tank fixing kit collar Ø123 (screws and O-Ring)
					Nominal	Full	Usable		
02				135	1.5	1.3	1	90310491	17010087
03	G	(H)	00	235	2.5	2.5	2	90310484	
04				295	4	3.4	2.5	90310422	

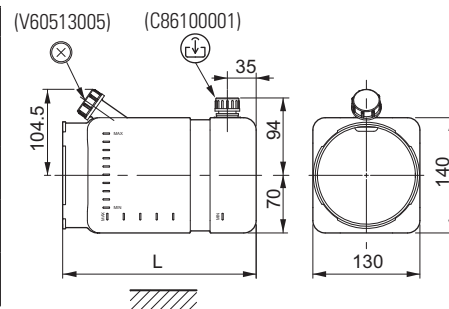

Operating temperature -10°C ÷ +70°C - (1) Variant - OMIT if without tank but with tubes kit

(..) spare parts

Other variants

Variant	Tank	Variant	Tank	Variant	Tank	Variant	Tank

IV
V

* ** * (V) ** * - **Square polyethylene tanks capacity 1.5-2.5-4 liters - Vertical mounting**

Capacity	Features	Mounting	Variant (1)	L (mm)	Capacity (liters)			Tank (with plugs, clamp, nuts)	Tank fixing kit collar Ø123 (screws and O-Ring)
					Nominal	Full	Usable		
02				135	1.5	1.1	0.7	90310486	17010087
03	G	(V)	00	235	2.5	2.7	2.3	90310419	
04				296	4	3.5	3.1	90310402	

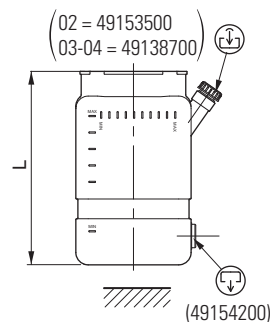

Operating temperature -10°C ÷ +70°C - (1) Variant - OMIT if without tank but with tubes kit

(..) spare parts

Other variants

Variant	Tank	Variant	Tank	Variant	Tank	Variant	Tank

Sect. IV - Tanks / Sect. V - Tubes kit

* ** * (H) ** * - **Square polyethylene tanks capacity 4 liters - Horizontal mounting**

Capacity	Features	Mounting	Variant (1)	L (mm)	Capacity (liters)			Tank (with plugs, clamp, nuts)	Tank fixing kit collar Ø123 (screws and O-Ring)
					Nominal	Full	Usable		
04	L	(H)	00	210	4	3.6	3	90310331	17010087

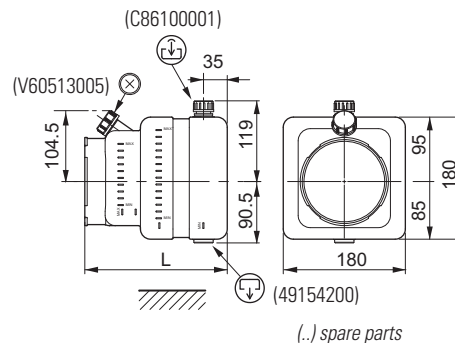

Operating temperature -10°C ÷ +70°C - (1) Variant - OMIT if without tank but with tubes kit

(..) spare parts

Other variants

Variant	Tank	Variant	Tank	Variant	Tank	Variant	Tank

IV
V

* ** * (V) ** * - **Square polyethylene tanks capacity 4 liters - Vertical mounting**

Capacity	Features	Mounting	Variant (1)	L (mm)	Capacity (liters)			Tank (with plugs, clamp, nuts)	Tank fixing kit collar Ø123 (screws and O-Ring)
					Nominal	Full	Usable		
04	L	(V)	00	210	4	3.7	3	90310332	17010087

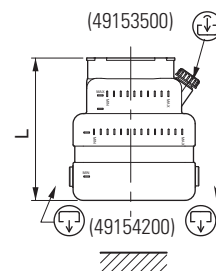

Operating temperature -10°C ÷ +70°C - (1) Variant - OMIT if without tank but with tubes kit

(..) spare parts

Other variants

Variant	Tank	Variant	Tank	Variant	Tank	Variant	Tank
04 L (V) 01	90310433						

*** ** * (*) ** *** - **Square polyethylene tanks capacity 7-10 liters - Horizontal mounting**

Capacity	Features	Mounting	Variant (1)	L (mm)	Capacity (liters)			Tank (with plugs, clamp, nuts)	Tank fixing kit collar Ø123 (screws and O-Ring)
					Nominal	Full	Usable		
07	L (H) 00			310	7	6.7	5.5	90310330	17010087
10				410	10	8.7	7.5	90310339	

Operating temperature -10°C ÷ +70°C - (1) Variant - OMIT if without tank but with tubes kit

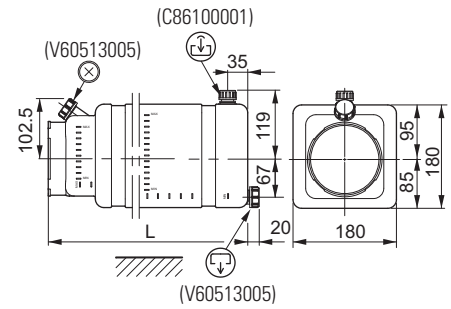

(..) spare parts

*** ** * (*) ** *** - **Square polyethylene tanks capacity 7-10 liters - Vertical mounting**

Capacity	Features	Mounting	Variant (1)	L (mm)	Capacity (liters)			Tank (with plugs, clamp, nuts)	Tank fixing kit collar Ø123 (screws and O-Ring)
					Nominal	Full	Usable		
07	L (V) 00			310	7	6.7	6	90310403	17010087
10				410	10	9.8	9	90310338	

Operating temperature -10°C ÷ +70°C - (1) Variant - OMIT if without tank but with tubes kit

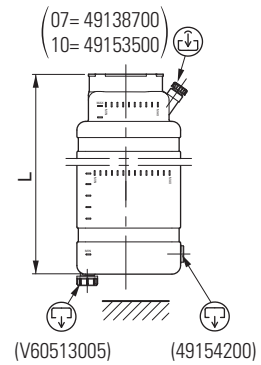

(..) spare parts

**IV
V**

*** ** * (*) ** *** - **Square polyethylene tanks capacity 9 liters - Vertical mounting**

Capacity	Features	Mounting	Variant (1)	L (mm)	Capacity (liters)			Tank (with plugs, clamp, nuts)	Tank fixing kit collar Ø123 (screws and O-Ring)
					Nominal	Full	Usable		
09	L (V) 00			370	9	8.6	8	90310371	17010087

Operating temperature -10°C ÷ +70°C - (1) Variant - OMIT if without tank but with tubes kit

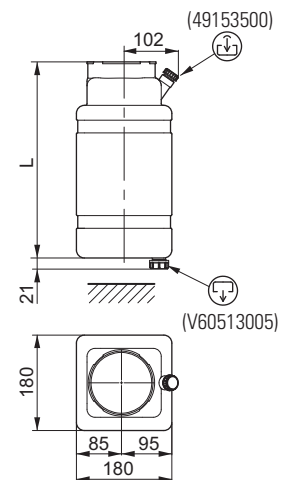

(..) spare parts

Sect. IV - Tanks / Sect. V - Tubes kit

*** ** * (H) ** *** - **Special square polyethylene tanks capacity 7 liters - Horizontal mounting**

Capacity	Features	Mounting	Variant (1)	L (mm)	Capacity (liters)			Tank (with plugs, clamp, nuts)	Tank fixing kit collar Ø123 (screws and O-Ring)
					Nominal	Full	Usable		
07	M	(H)	00	335	7	7.3	6.6	90310380	17010087

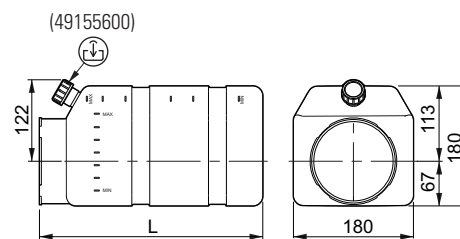

Operating temperature -10°C ÷ +70°C - (1) Variant - OMIT if without tank but with tubes kit

(..) spare parts

Other variants

Variant				Tank				Variant				Tank				Variant				Tank			

IV
V

*** ** * (V) ** *** - **Special square polyethylene tanks capacity 7 liters - Vertical mounting**

Capacity	Features	Mounting	Variant (1)	L (mm)	Capacity (liters)			Tank (with plugs, clamp, nuts)	Tank fixing kit collar Ø123 (screws and O-Ring)
					Nominal	Full	Usable		
07	M	(V)	00	335	7	7.2	6.4	90310380	17010087

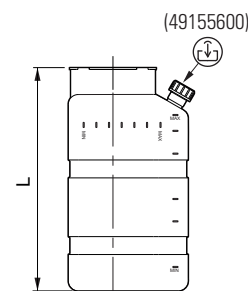

Operating temperature -10°C ÷ +70°C - (1) Variant - OMIT if without tank but with tubes kit

(..) spare parts

Other variants

Variant				Tank				Variant				Tank				Variant				Tank			

Sect. IV - Tanks / Sect. V - Tubes kit

* ** * (*) ** /* - Tanks orientation according to the mounting position

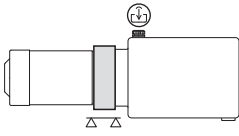
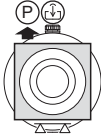
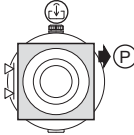
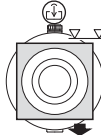
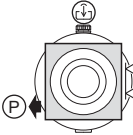
For tanks			(*)	Mounting position	/* Orientation			
S	**	A B C D			/1 (standard)	/2	/3	/4
			(H)	Horizontal 	 (1)			

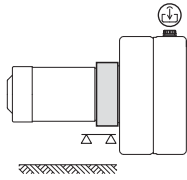
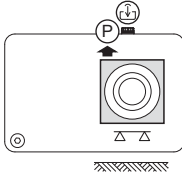
For tanks			(*)	Mounting position	/* Orientation			
S	09	E			/1 (standard)			
			(H)	Horizontal 				

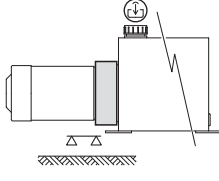
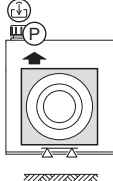
For tanks			(*)	Mounting position	/* Orientation			
S	25	E			/1 (standard)			
			(H)	Horizontal 				

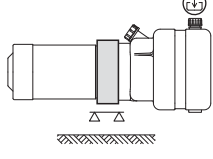
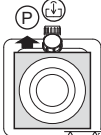
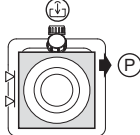
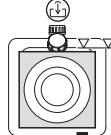
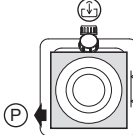
For tanks			(*)	Mounting position	/* Orientation			
S	**	F G L			/1 (standard)	/2	/3	/4
			(H)	Horizontal 	 (1)			

(1) Orientation TO BE USED with blocks

IV
V

Sect. IV - Tanks / Sect. V - Tubes kit

* ** * (*) ** /* - Tanks orientation according to the mounting position

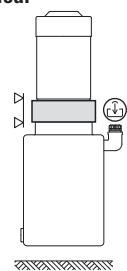
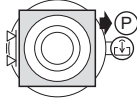
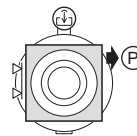
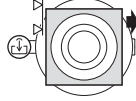
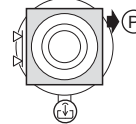
For tanks			(*)	Mounting position	/* Orientation			
			(*)		/1 (standard)	/2	/3	/4
S	**	A B C D F G L	(V)	Vertical 	 (2)			

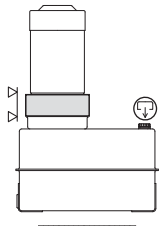
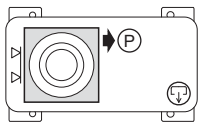
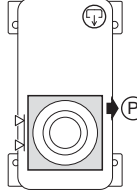
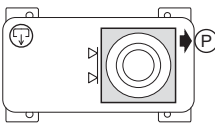
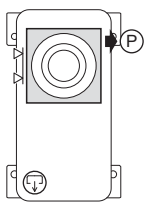
For tanks			(*)	Mounting position	/* Orientation			
			(*)		/1 (standard)	/2	/3	/4
S	07	E	(V)	Vertical 	 (1)			

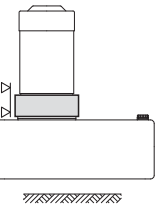
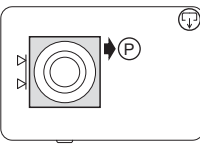
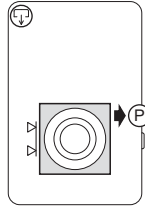
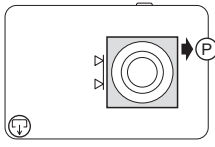
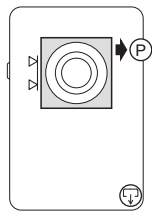
For tanks			(*)	Mounting position	/* Orientation			
			(*)		/1 (standard)	/2	/3	/4
S	09 25	E	(V)	Vertical 	 (1)			

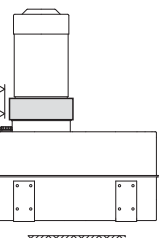
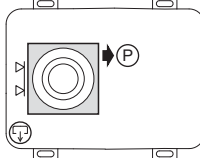
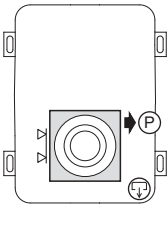
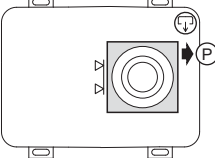
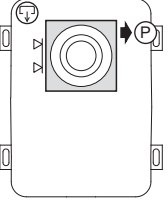
For tanks			(*)	Mounting position	/* Orientation			
			(*)		/1 (standard)	/2	/3	/4
S	14	E	(V)	Vertical 	 (1)			

(1) Orientation TO BE USED with blocks
 (2) D Orientation DO NOT USE with blocks

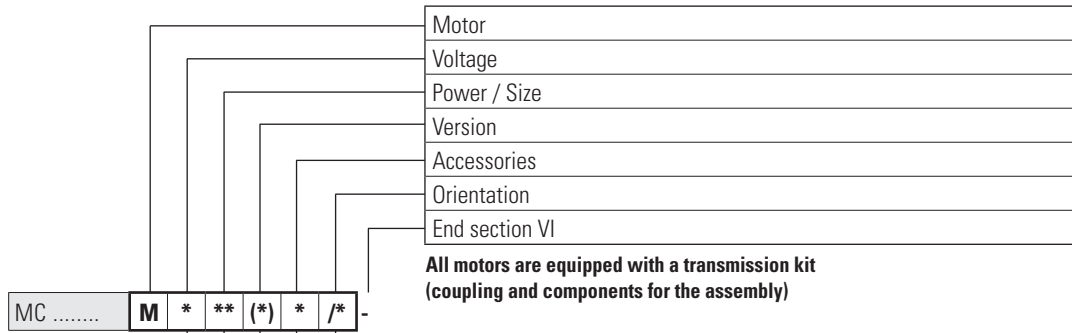

All motors are equipped with a transmission kit (coupling and components for the assembly)

* Voltage	** Power	Size	(*) Version	Page	* Accessories	/* Orientation	Page	
2 12 VDC	GA	350 W	Ø 80	(1) Std	42	0 - B	/1 /2 Std /3 /4	46
	GC	700 W	Ø 80	(1) Std	42	0 - B		
	AA	1500 W	Ø 115	(1) Std	43	0 - B - C - D - F - G - H		
	EN	1600 W	Ø 115	(1) Std	43	0 - B - C - E		
	GN	1600 W	Ø 115	(1) Std	44	0 - B - C - E		
4 24 VDC	GB	400 W	Ø 80	(1) Std	42	0 - B		
	GD	800 W	Ø 80	(1) Std	42	0 - B		
	AB	2000 W	Ø 115	(1) Std	43	0 - B - C - D - F - G - H		
	ES	2200 W	Ø 115	(1) Std	43	0 - B - C - E		
	GP	2200 W	Ø 115	(1) Std	44	0 - B - C - E		
	GJ	3000 W	Ø 125	(1) Std	44	0 - B - C - E		
	FB	3000 W	Ø 125	(1) Std	44	0 - B - C - E		

* Accessories description	Page
0 Without accessories	—
B Starting switch	45
C Thermal protection	—
D (*) Ventilation	45
E Starting switch + thermal protection	—
F (*) Starting switch + ventilation	—
G Thermal protection + ventilation	—
H (*) Starting switch + thermal protection + ventilation	—

(*)= IP protection level becomes effective after installation on power pack. Acquires IP 10 level with "ventilation" accessory.

For more details, features and performances DC motors, see catalog Dana code DOC00053.

Motors: 12 VDC 350 W / 24 VDC 400 W (permanent magnets)

	Voltage	W	A	rpm	Nm	S2 min	S3%	IP	IC	Ø mm	Code (⊗)
M 2 GA (1) * /*	12 VDC	350	40	3300	1.0	10	35	54	F	80	25021400
M 4 GB (1) * /*	24 VDC	400	30	3100	1.2	5	20	54	F	80	25021500

IP protection level becomes effective after installation on power pack.
 (⊗) Motor without accessories

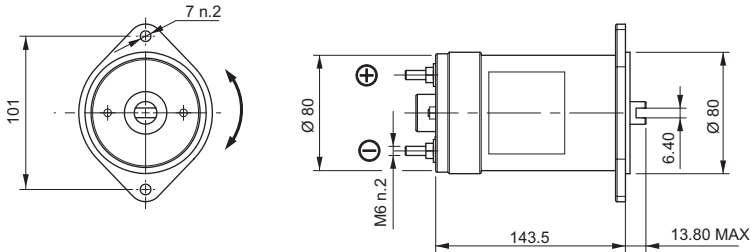

M * ** (*) * /* - Accessories (page 45)

* Description
0 Without accessories
B Starting switch 120A fixing with clamp

Code trasmission kit: page 53

Motors: 12 VDC 700 W / 24 VDC 800 W (permanent magnets)

	Voltage	W	A	rpm	Nm	S2 min	S3%	IP	IC	Ø mm	Code (⊗)
M 2 GC (1) * /*	12 VDC	700	90	3300	2.0	2.5	10	54	F	80	25021600
M 4 GD (1) * /*	24 VDC	800	70	3000	2.5	2	5	54	F	80	25021700

IP protection level becomes effective after installation on power pack.
 (⊗) Motor without accessories

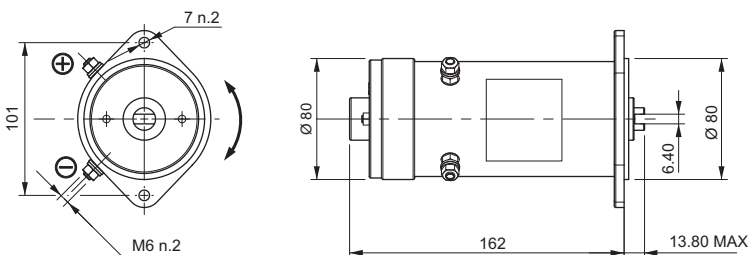

M * ** (*) * /* - Accessories (page 45)

* Description
0 Without accessories
B Starting switch 120A

Code trasmission kit: page 53

For more details, features and performances DC motors, see catalog Dana code DOC00053.

Motors: 12 VDC 1500 W / 24 VDC 2000 W (wound field compound)

	Voltage	W	A	rpm	Nm	S2 min	S3%	IP	IC	Ø mm	Code (⊗)
M 2 AA (1) * /*	12 VDC	1500	225	2500	5.5	1	5	54	F	115	25022200
M 4 AB (1) * /*	24 VDC	2000	150	2250	8	2	5	54	F	115	25022300

IP protection level becomes effective after installation on power pack.
 (⊗) Motor without accessories

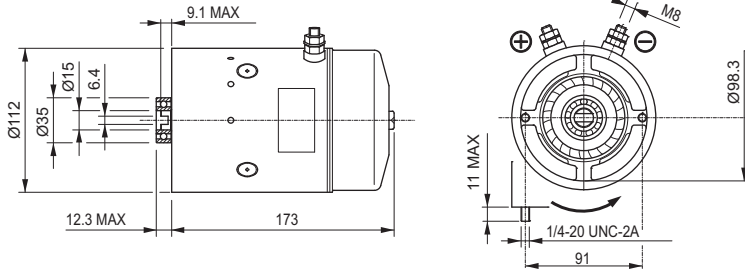

Code trasmission kit: page 53

M * ** (*) * /* - Accessories (page 45)

* Description
0 Without accessories
B Starting switch 120A
D Ventilation
F Ventilation + Starting switch
G Ventilation + Thermal protection
H Ventilation + Thermal protection + Starting switch

Acquires IP 10 protection level with "ventilation" accessory.

Motors: 12 VDC 1600 W / 24 VDC 2200 W (wound field compound)

	Voltage	W	A	rpm	Nm	S2 min	S3%	IP	IC	Ø mm	Code (⊗)
M 2 EN (1) * /*	12 VDC	1600	230	2600	5	2	10	54	F	115	25021100
M 4 ES (1) * /*	24 VDC	2200	140	2700	8	1.2	5	54	F	115	25021200

IP protection level becomes effective after installation on power pack.
 (⊗) Motor without accessories

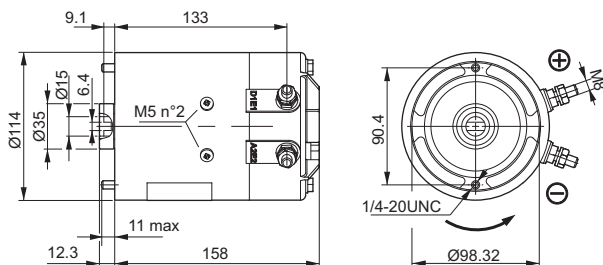

Code trasmission kit: page 53

M * ** (*) * /* - Accessories (page 45)

* Description
0 Without accessories
B Starting switch 120A
C Thermal protection
E Starting switch + thermal protection

For more details, features and performances DC motors, see catalog Dana code DOC00053.

Motors: 12 VDC 1600 W / 24 VDC 2200 W (wound field serie)

	Voltage	W	A	rpm	Nm	S2 min	S3%	IP	IC	Ø mm	Code (⊗)
M 2 GN (1) * /*	12 VDC	1600	220	2600	6	4	8	54	F	115	25022600
M 4 GP (1) * /*	24 VDC	2200	140	2600	6	2	7.5	54	F	115	25022700

IP protection level becomes effective after installation on power pack.
 (⊗) Motor without accessories

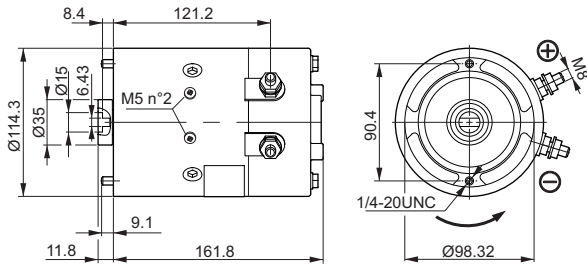

M * ** (*) * /* - Accessories (page 45)

* Description
0 Without accessories
B Starting switch 120A
Code trasmission kit: page 53

VI
DC

Motors: 24 VDC 3000 W (wound field compound)

	Voltage	W	A	rpm	Nm	S2 min	S3%	IP	IC	Ø mm	Code (⊗)
M 4 FB (1) * /*	24 VDC	3000	200	3300	8.5	4	15	20	F	125	25021300
M 4 GJ (1) * /*	24 VDC	3000	180	3500	8.5	3.5	15	20	F	125	25022400

IP protection level becomes effective after installation on power pack.
 (⊗) Motor without accessories

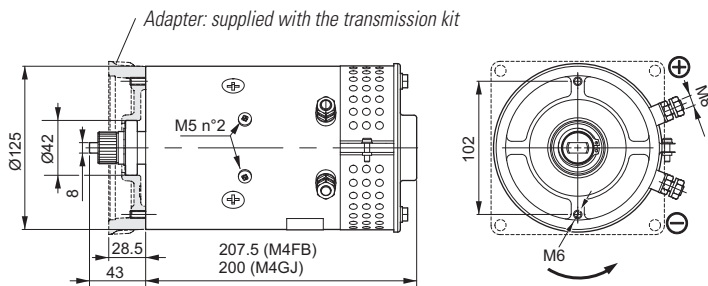

M * ** (*) * /* - Accessories (page 45)

** * Description
0 Without accessories
B Starting switch 150A
D Ventilation
F Ventilation + Starting switch
G Ventilation + Thermal protection
H Ventilation + Thermal protection + Starting switch
Code trasmission kit: page 53

For more details, features and performances DC motors, see catalog Dana code DOC00053.

M * ** (*) **C** /* - **Accessory: Thermal protection**

Thermal protection		
Code	Ø mm	For motors
90340009	16	M2EN - M4ES

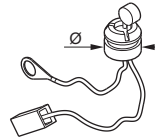

M * ** (*) **B** /* - **Accessory: Starting switch**

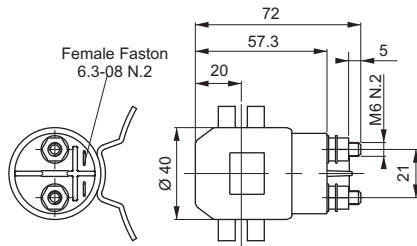

120A starting switch		
Code (•)	VDC	For motors
KIT07012.027	12	M2GA - M2GC
KIT07012.032	24	M4GB - M4GD
KIT07012.033	12	M2AA
KIT07012.034	24	M4AB
KIT07012.025	12	M2EN - M2GN
KIT07012.026	24	M4ES - M2GP

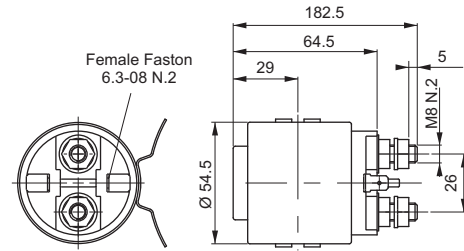

150A starting switch		
Code (•)	VDC	For motors
KIT07012.019	24	M4FB - M4GJ

(•) Complete kit with all assembly components.

For more details, features and performances DC motors, see catalog Dana code DOC00053.

VI
DC

M * ** (*) ***** /* - **Accessory: Ventilation (motor included)**

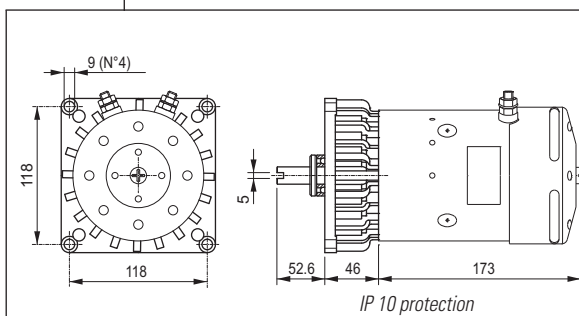

*	Code (•)	VDC	For motors
D	KIT01008.065	12	M2AA
G	KIT01008.088	12	M2AA + thermal protection
D	KIT01008.067	24	M4AB
G	KIT01008.077	24	M4AB + thermal protection

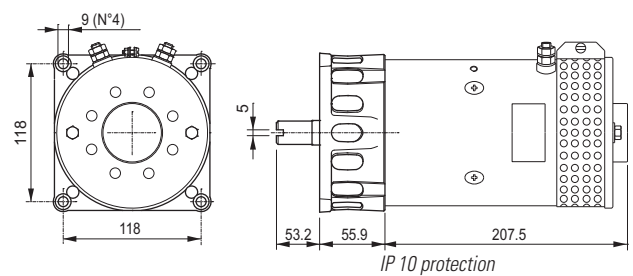

*	Code (•)	VDC	For motors
D	KIT01008.118	24	M4FB
D	KIT01008.215	24	M4GJ
G	KIT01008.119	24	M4FB + thermal protection

(•) Complete kit with all assembly components (motor, transmission kit, etc).

For more details, features and performances DC motors, see catalog Dana code DOC00053.

M * ** (*) * /* - Motor orientation

Starting switch and poles position.

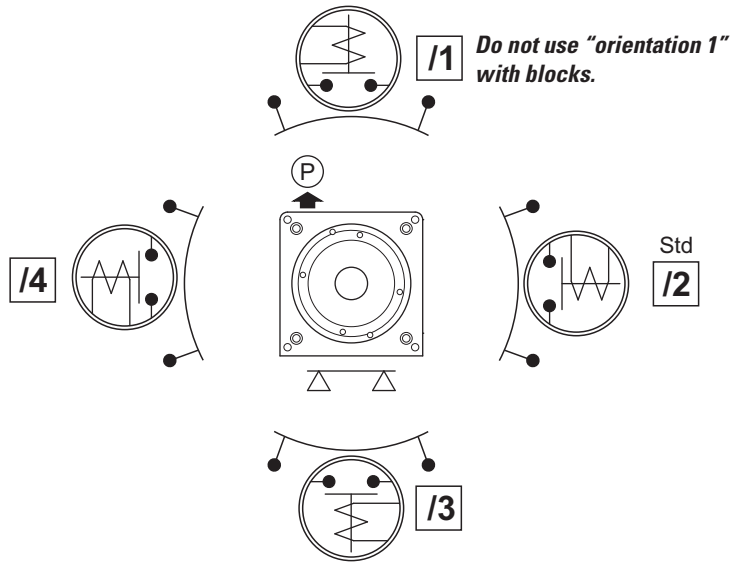
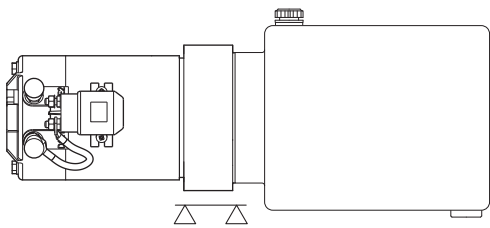

VI
DC

Sect. VI - AC Motors

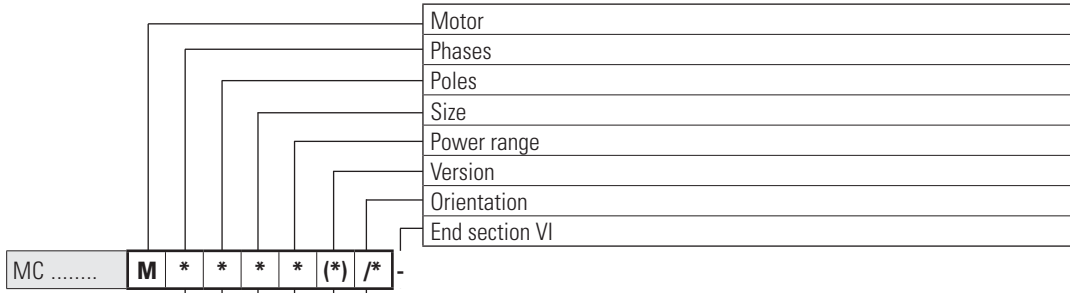

*	Phases	* Poles	*	Size	* Power range		Page	(*) Version	/* Orientation	Page			
					Power	Voltage							
M	Monofase	2	L	71	A	0.37 kW	230 Vac 50 Hz	48	(1) Std	/1 /2 /3 /4 Std	52		
			L	71	B	0.55 kW	230 Vac 50 Hz	48					
			S	71	A	0.75 kW	230 Vac 50 Hz	50					
			S	71	B	1.10 kW	230 Vac 50 Hz	50					
			M	80	A	0.75 kW	230 Vac 50 Hz	48					
			M	80	B	1.10 kW	230 Vac 50 Hz	48					
			N	90	A	1.50 kW	230 Vac 50 Hz	48					
			N	90	B	2.20 kW	230 Vac 50 Hz	48					
			P	100	A	3.00 kW	230 Vac 50 Hz	48					
			L	71	A	0.25 kW	230 Vac 50 Hz	48					
			L	71	B	0.37 kW	230 Vac 50 Hz	48					
			S	71	C	0.85 kW	230 Vac 50 Hz	50					
		M	80	A	0.55 kW	230 Vac 50 Hz	48						
		M	80	B	0.75 kW	230 Vac 50 Hz	48						
		N	90	A	1.10 kW	230 Vac 50 Hz	48						
		N	90	B	1.50 kW	230 Vac 50 Hz	48						
		V	90	A	1.80 kW	230 Vac 50 Hz	51						
		V	90	B	3.00 kW	230 Vac 50 Hz	51						
		P	100	A	2.20 kW	230 Vac 50 Hz	48						
		T	Trifase	2	R	63	A	0.18 kW				230/400 Vac 50 Hz	49
					R	63	B	0.25 kW				230/400 Vac 50 Hz	49
					L	71	A	0.37 kW				230/400 Vac 50 Hz	49
					L	71	B	0.55 kW				230/400 Vac 50 Hz	49
					S	71	A	0.75 kW				230/400 Vac 50 Hz	50
S	71				B	1.10 kW	230/400 Vac 50 Hz	50					
M	80				A	0.75 kW	230/400 Vac 50 Hz	49					
M	80				B	1.10 kW	230/400 Vac 50 Hz	49					
T	80				A	2.70 kW	230/400 Vac 50 Hz	51					
T	80				B	2.70 kW	230/400 Vac 50 Hz	51					
N	90				A	1.50 kW	230/400 Vac 50 Hz	49					
N	90				B	2.20 kW	230/400 Vac 50 Hz	49					
P	100				A	3.00 kW	230/400 Vac 50 Hz	49					
P	112				B	4.00 kW	230/400 Vac 50 Hz	49					
R	63				A	0.12 kW	230/400 Vac 50 Hz	49					
R	63				B	0.18 kW	230/400 Vac 50 Hz	49					
L	71				A	0.25 kW	230/400 Vac 50 Hz	49					
L	71				B	0.37 kW	230/400 Vac 50 Hz	49					
S	71			A	0.75 kW	230/400 Vac 50 Hz	50						
M	80			A	0.55 kW	230/400 Vac 50 Hz	49						
M	80			B	0.75 kW	230/400 Vac 50 Hz	49						
T	80			A	2.20 kW	230/400 Vac 50 Hz	51						
T	80			B	2.20 kW	230/400 Vac 50 Hz	51						
T	80			C	2.20 kW	230/400 Vac 50 Hz	51						
T	80			D	3.00 kW	230/400 Vac 50 Hz	51						
N	90			A	1.10 kW	230/400 Vac 50 Hz	49						
N	90			B	1.50 kW	230/400 Vac 50 Hz	49						
P	100			A	2.20 kW	230/400 Vac 50 Hz	49						
P	100			B	3.00 kW	230/400 Vac 50 Hz	49						
P	112			C	4.00 kW	230/400 Vac 50 Hz	49						

Motors supplied with all assembly components (transmission kit, coupling, etc).

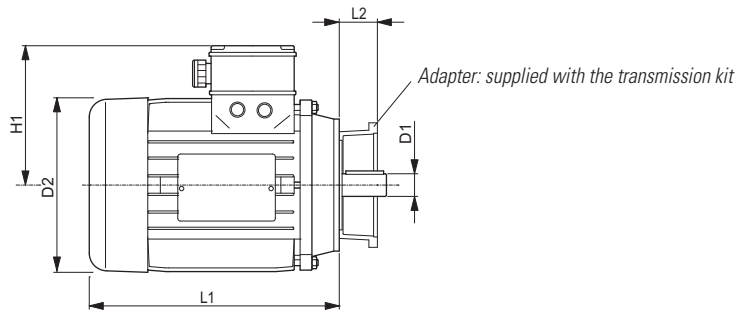

Single-phase motors 2-4 Poles - 230 Vac 50Hz - Version B14

M	M	Poles	Size	D1 (•)	D2 (•)	H1 (•)	L1 (•)	Power range					Cable gland metric thread	Adapter			Single Motor	Transmission kit (for pump)					
								Power kW	Voltage	IP	IC	S1		Code	Screw UNI 5931	L2							
M	M	2	L	A	(1)	2	2	71	14	148	115	208	0.37	230 Vac 50 Hz	54	F	Si	20-25	61000700	M6x20	19.5	M12E2000	KIT01008.006 (Gr.05)
M	M	2	L	B	(1)	2	2	71	14	148	115	208	0.55	230 Vac 50 Hz	54	F	Si	20-25	61000700	M6x20	19.5	M12F2000	KIT01008.001 (Gr.1)
M	M	2	M	A	(1)	2	2	80	19	170	126	234	0.75	230 Vac 50 Hz	54	F	Si	20-25	61000800	M6x20	30.4	M13G2000	KIT01008.005 (Gr.05)
M	M	2	M	B	(1)	2	2	80	19	170	126	234	1.10	230 Vac 50 Hz	54	F	Si	20-25	61000800	M6x20	30.4	M13H2000	KIT01008.002 (Gr.1)
M	M	2	N	A	(1)	2	2	90	24	185	142	247	1.50	230 Vac 50 Hz	54	F	Si	20-25	61000900	M8x21	40.4	M14L2000	KIT01008.007 (Gr.05)
M	M	2	N	B	(1)	2	2	90	24	185	142	272	2.20	230 Vac 50 Hz	54	F	Si	20-25	61000900	M8x21	40.4	M14N2000	KIT01008.003 (Gr.1)
M	M	2	P	A	(1)	2	2	100	28	210	155	310	3.00	230 Vac 50 Hz	54	F	Si	25-32	61001000	M8x28	75	M15P2000	KIT01008.013 (Gr.05) KIT01008.004 (Gr.1)
M	M	4	L	A	(1)	2	4	71	14	148	115	208	0.25	230 Vac 50 Hz	54	F	Si	20-25	61000700	M6x20	19.5	M12D4000	KIT01008.006 (Gr.05)
M	M	4	L	B	(1)	2	4	71	14	148	115	208	0.37	230 Vac 50 Hz	54	F	Si	20-25	61000700	M6x20	19.5	M12E4000	KIT01008.001 (Gr.1)
M	M	4	M	A	(1)	2	4	80	19	170	126	234	0.55	230 Vac 50 Hz	54	F	Si	20-25	61000800	M6x20	30.4	M13F4000	KIT01008.005 (Gr.05)
M	M	4	M	B	(1)	2	4	80	19	170	126	234	0.75	230 Vac 50 Hz	54	F	Si	20-25	61000800	M6x20	30.4	M13G4000	KIT01008.002 (Gr.1)
M	M	4	N	A	(1)	2	4	90	24	185	142	247	1.10	230 Vac 50 Hz	54	F	Si	20-25	61000900	M8x21	40.4	M14H4000	KIT01008.007 (Gr.05)
M	M	4	N	B	(1)	2	4	90	24	185	142	272	1.50	230 Vac 50 Hz	54	F	Si	20-25	61000900	M8x21	40.4	M14L4000	KIT01008.003 (Gr.1)
M	M	4	P	A	(1)	2	4	100	28	210	155	310	2.20	230 Vac 50 Hz	54	F	Si	25-32	61001000	M8x28	75	M15N4000	KIT01008.013 (Gr.05) KIT01008.004 (Gr.1)

(•) = Approximate dimensions

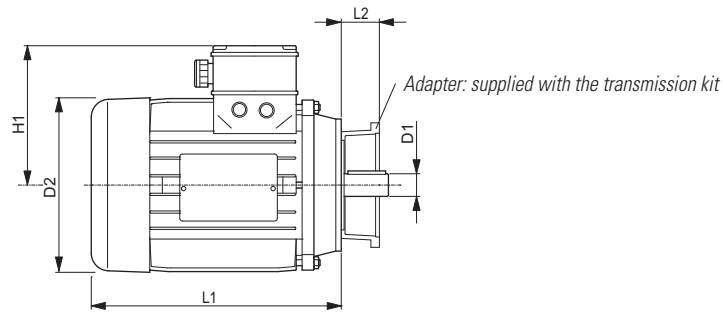

Three-phase motors 2-4 Poles - 230/400 Vac 50Hz - Version B14

M	T	Poles	Size	D1 (*)	D2 (*)	H1 (*)	L1 (*)	Power range					Cable gland metric thread	Adapter			Single Motor	Transmission kit (for pump)					
								Power kW	Voltage	IP	IC	S3		Code	Screw UNI 5931	L2							
M	T	2	R	A	(1)	3	2	63	11	125	95	189	0.18	230/400 Vac 50 Hz	54	F	60%	16-20	61004300	M5x16	19.5	M31C2000	KIT01008.008 (Gr.05)
M	T	2	R	B	(1)	3	2	63	11	125	95	189	0.25	230/400 Vac 50 Hz	54	F	60%	16-20	61004300	M5x16	19.5	M31D2000	KIT01008.014 (Gr.1)
M	T	2	L	A	(1)	3	2	71	14	148	115	208	0.37	230/400 Vac 50 Hz	54	F	60%	20-25	61000700	M6x20	19.5	M32E2000	KIT01008.006 (Gr.05)
M	T	2	L	B	(1)	3	2	71	14	148	115	208	0.55	230/400 Vac 50 Hz	54	F	60%	20-25	61000700	M6x20	19.5	M32F2000	KIT01008.001 (Gr.1)
M	T	2	M	A	(1)	3	2	80	19	170	126	234	0.75	230/400 Vac 50 Hz	54	F	60%	20-25	61000800	M6x20	30.4	M33G2000	KIT01008.005 (Gr.05)
M	T	2	M	B	(1)	3	2	80	19	170	126	234	1.10	230/400 Vac 50 Hz	54	F	60%	20-25	61000800	M6x20	30.4	M33H2000	KIT01008.002 (Gr.1)
M	T	2	N	A	(1)	3	2	90	24	185	142	247	1.50	230/400 Vac 50 Hz	54	F	60%	20-25	61000900	M8x21	40.4	M34L2000	KIT01008.007 (Gr.05)
M	T	2	N	B	(1)	3	2	90	24	185	142	272	2.20	230/400 Vac 50 Hz	54	F	60%	20-25	61000900	M8x21	40.4	M34N2000	KIT01008.003 (Gr.1)
M	T	2	P	A	(1)	3	2	100	28	210	155	310	3.00	230/400 Vac 50 Hz	54	F	60%	25-32	61001000	M8x28	75	M35P2000	KIT01008.013 (Gr.05)
M	T	2	P	B	(1)	3	2	112	28	225	182	325	4.00	230/400 Vac 50 Hz	54	F	60%	25-32	61001000	M8x28	75	M36Q2000	KIT01008.004 (Gr.1)
M	T	4	R	A	(1)	3	4	63	11	125	95	189	0.12	230/400 Vac 50 Hz	54	F	60%	16-20	61004300	M5x16	19.5	M31B4000	KIT01008.008 (Gr.05)
M	T	4	R	B	(1)	3	4	63	11	125	95	189	0.18	230/400 Vac 50 Hz	54	F	60%	16-20	61004300	M5x16	19.5	M31C4000	KIT01008.014 (Gr.1)
M	T	4	L	A	(1)	3	4	71	14	148	115	208	0.25	230/400 Vac 50 Hz	54	F	60%	20-25	61000700	M6x20	19.5	M32D4000	KIT01008.006 (Gr.05)
M	T	4	L	B	(1)	3	4	71	14	148	115	208	0.37	230/400 Vac 50 Hz	54	F	60%	20-25	61000700	M6x20	19.5	M32E4000	KIT01008.001 (Gr.1)
M	T	4	M	A	(1)	3	4	80	19	170	126	234	0.55	230/400 Vac 50 Hz	54	F	60%	20-25	61000800	M6x20	30.4	M33F4000	KIT01008.005 (Gr.05)
M	T	4	M	B	(1)	3	4	80	19	170	126	234	0.75	230/400 Vac 50 Hz	54	F	60%	20-25	61000800	M6x20	30.4	M33G4000	KIT01008.002 (Gr.1)
M	T	4	N	A	(1)	3	4	90	24	185	142	247	1.10	230/400 Vac 50 Hz	54	F	60%	20-25	61000900	M8x21	40.4	M34H4000	KIT01008.007 (Gr.05)
M	T	4	N	B	(1)	3	4	90	24	185	142	272	1.50	230/400 Vac 50 Hz	54	F	60%	20-25	61000900	M8x21	40.4	M34L4000	KIT01008.003 (Gr.1)
M	T	4	P	A	(1)	3	4	100	28	210	155	310	2.20	230/400 Vac 50 Hz	54	F	60%	25-32	61001000	M8x28	75	M35N4000	KIT01008.013 (Gr.05)
M	T	4	P	B	(1)	3	4	100	28	210	155	310	3.00	230/400 Vac 50 Hz	54	F	60%	25-32	61001000	M8x28	75	M35P4000	KIT01008.004 (Gr.1)
M	T	4	P	C	(1)	3	4	112	28	225	182	325	4.00	230/400 Vac 50 Hz	54	F	60%	25-32	61001000	M8x28	75	M36Q4000	

(*)= Approximate dimensions

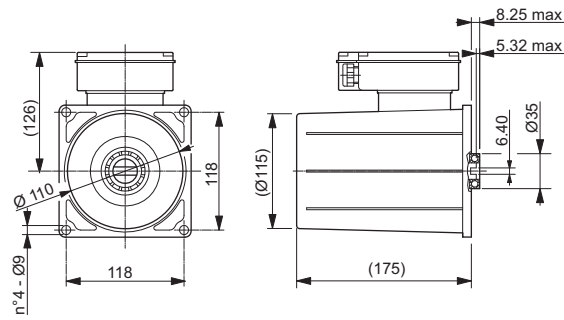

Single-phase motors 2-4 Poles - 230 Vac 50Hz - Special housing

Phases	Poles	Size	Power range				Cable gland metric thread	Single Motor	Transmission kit	Note	
			Power kW	Voltage	IP	IC					Service
M	M 2 S A (1)	2 2 71	0.75	230 Vac 50 Hz	54	F	Light-duty	20	M12GY3FF.001	KIT01008.126 (per pompe Gr.1) KIT01008.130 (per pompe Gr.0.5)	Without fan
M	M 2 S B (1)	2 2 71	1.10	230 Vac 50 Hz	54	F	Light-duty	20	M12HY3FF.000	KIT01008.126 (per pompe Gr.1) KIT01008.130 (per pompe Gr.0.5)	Without fan
M	M 4 S C (1)	2 4 71	0.85	230 Vac 50 Hz	54	F	Light-duty	20	M12YY3FF.001	KIT01008.126 (per pompe Gr.1) KIT01008.130 (per pompe Gr.0.5)	Without fan

IP protection level becomes effective after installation on power pack.

VI
AC

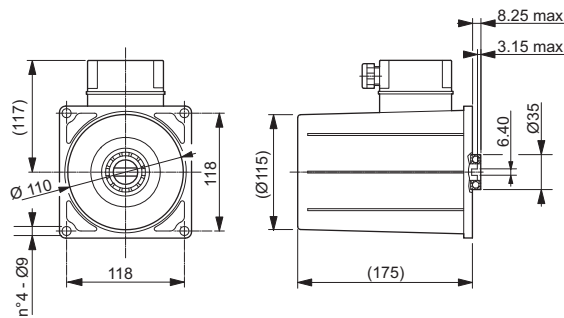

Three-phase motors 2-4 Poles - 230/400 Vac 50Hz - Direct fixing

Phases	Poles	Size	Power range				Cable gland metric thread	Single Motor	Transmission kit	Note	
			Power kW	Voltage	IP	IC					Service
M	T 2 S A (1)	3 2 71	0.75	230/400 Vac 50 Hz	54	F	Light-duty	20	M32GY3FL.003	KIT01008.126 (per pompe Gr.1) KIT01008.130 (per pompe Gr.0.5)	Without fan
M	T 2 S B (1)	3 2 71	1.10	230/400 Vac 50 Hz	54	F	Light-duty	20	M32HY3FL.001	KIT01008.126 (per pompe Gr.1) KIT01008.130 (per pompe Gr.0.5)	Without fan
M	T 4 S A (1)	3 4 71	0.75	230/400 Vac 50 Hz	54	F	Light-duty	20	M32GY3FL.002	KIT01008.126 (per pompe Gr.1) KIT01008.130 (per pompe Gr.0.5)	Without fan

IP protection level becomes effective after installation on power pack.

With fan

Without fan

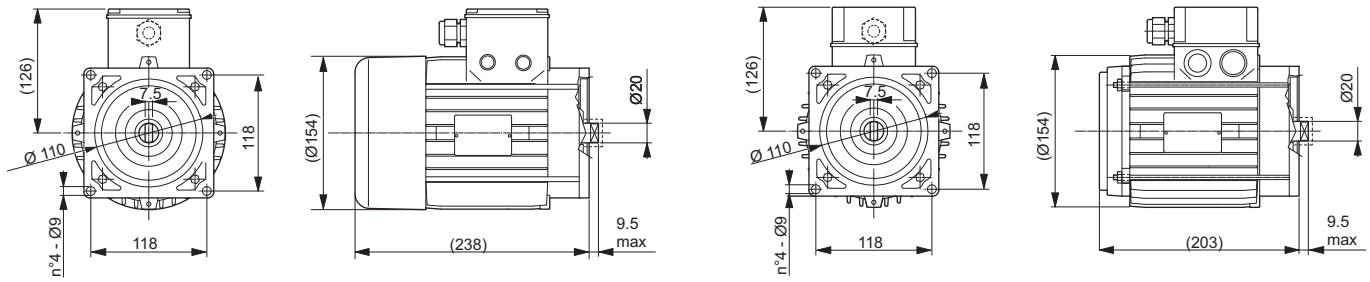

Three-phase motors 2-4 Poles - 230/400 Vac 50Hz - Direct fixing

Phases	Poles	Size	Power range				Cable gland metric thread	Single Motor	Transmission kit	Note	
			Power kW	Voltage	IP	IC					Service
M	T 2 T A (1)	3 2 80	2.7	230/400 Vac 50 Hz	44	F	Light-duty	20-25	M33YD1FF.000	KIT01008.131 (per pompe Gr.1)	With fan
M	T 2 T B (1)	3 2 80	2.7	230/400 Vac 50 Hz	44	F	Light-duty	20-25	M33YD1FF.001	KIT01008.131 (per pompe Gr.1)	Without fan
M	T 4 T A (1)	3 4 80	2.2	230/400 Vac 50 Hz	44	F	S3 - 4%	20-25	M33NF1FF.001	KIT01008.131 (per pompe Gr.1)	Without fan
M	T 4 T B (1)	3 4 80	2.2	230/400 Vac 50 Hz	55	F	S3 - 4%	20-25	M33NF4FF.000	KIT01008.131 (per pompe Gr.1)	With fan
M	T 4 T C (1)	3 4 80	2.2	230/400 Vac 50 Hz	44	F	S3 - 4%	20-25	M33NF1FF.000	KIT01008.131 (per pompe Gr.1)	With fan
M	T 4 T D (1)	3 4 80	3.0	230/400 Vac 50 Hz	54	F	Light-duty	20-25	M33PF3FF.000	KIT01008.131 (per pompe Gr.1)	With fan

IP protection level becomes effective after installation on power pack.

VI
AC

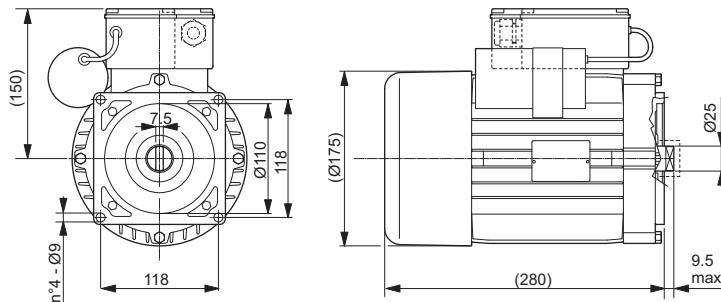

Single-phase motors 4 Poles - 230 Vac 50Hz - Direct fixing

Phases	Poles	Size	Power range				Cable gland metric thread	Single Motor	Transmission kit	Note	
			Power kW	Voltage	IP	IC					Service
M	M 4 V A (1)	2 4 90	1.8	230 Vac 50 Hz	44	F	Light-duty	20-25	M14MF1FF.001	KIT01008.131 (per pompe Gr.1)	With fan Start torque 13Nm
M	M 4 V B (1)	2 4 90	3.0	230 Vac 50 Hz	55	F	S3 - 7%	20-25	M14PF4FF.000	KIT01008.131 (per pompe Gr.1)	With fan

IP protection level becomes effective after installation on power pack.

M * * * * (*) / * - Motor orientation

Connector box position on power pack.

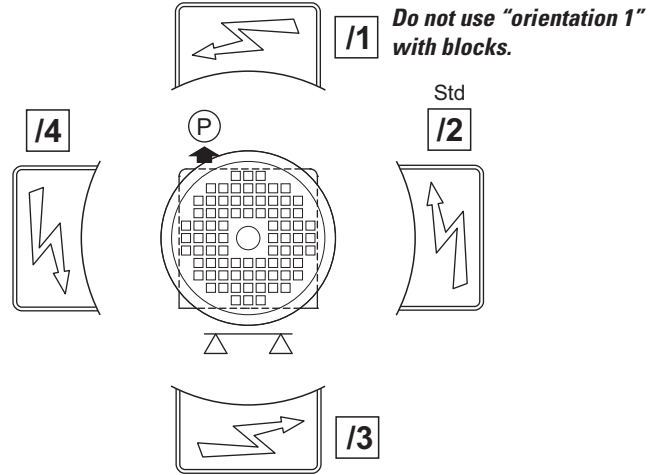
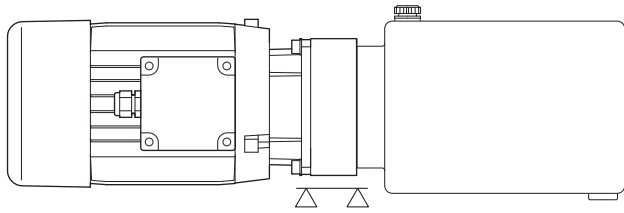

Transmission kit (only for motors on the catalog)
Type
End section VII

Specify the transmission kit whether you requested the joint and accessories assembly (without motor).

MC T **

**	Transmission kit				For DC motors
	Code	Pump	L	Ø	
01	KIT08019.027	Gr. 0.5	52.7	14	GA (350 W - Ø 80 - Page 42) GC (700 W - Ø 80 - Page 42) GB (400 W - Ø 80 - Page 42) GD (800 W - Ø 80 - Page 42)
	KIT08019.026	Gr. 1	36.6	14	

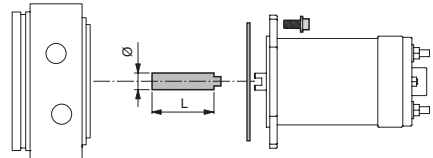

**	Transmission kit				For DC motors
	Code	Pump	L	Ø	
02	KIT08019.028	Gr. 0.5	53.9	14	AA (1500 W - Ø 115 - Page 43) EN (1600 W - Ø 115 - Page 43) AB (2000 W - Ø 115 - Page 43) ES (2200 W - Ø 115 - Page 43) GN (1600 W - Ø 115 - Page 44) GP (2200 W - Ø 115 - Page 44)
	KIT08019.025	Gr. 1	37.9	14	

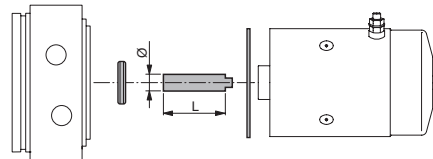

**	Transmission kit				For DC motors
	Code	Pump	L	Ø	
03	KIT08019.029	Gr. 1	34.6	20	GJ (3000 W - Ø 125 - Page 44) FB (3000 W - Ø 125 - Page 44)

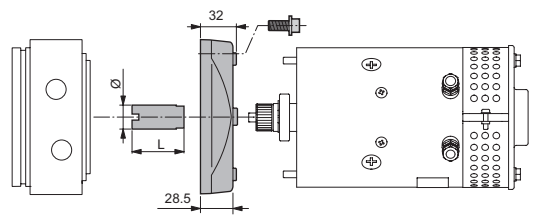

Note: in ventilated motors (accessory "D" page 44) the transmission is included in the kit ventilation

Sect. VII - Transmission kit AC motors

Transmission kit (only for motors on the catalog)
Type
End section VII

Specify the transmission kit whether you requested the joint and accessories assembly (without motor).

MC T **

**	Transmission kit						For AC motors		Page
	Code	Pump	L	Ø	L1	Z	Ref.	Size	
1R	KIT01008.008	Gr. 0.5	16	14	49.5	62.7	R	63 (B14)	49
	KIT01008.014	Gr. 1	19.5	20	30	42.8			

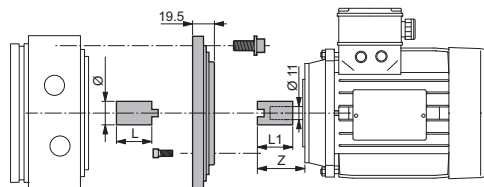

**	Transmission kit						For AC motors		Page
	Code	Pump	L	Ø	L1	Z	Ref.	Size	
1L	KIT01008.006	Gr. 0.5	36.1	14	26.5	42	L	71 (B14)	48 49
	KIT01008.001	Gr. 1	19.5	20	26.5	42			

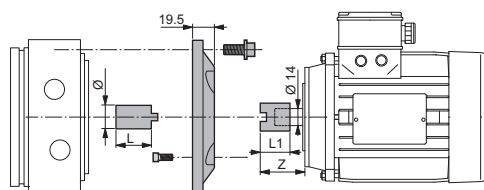

**	Transmission kit						For AC motors		Page
	Code	Pump	L	Ø	L1	Z	Ref.	Size	
1M	KIT01008.005	Gr. 0.5	36.1	14	38	53	M	80 (B14)	48 49
	KIT01008.002	Gr. 1	19.5	20	38	53			

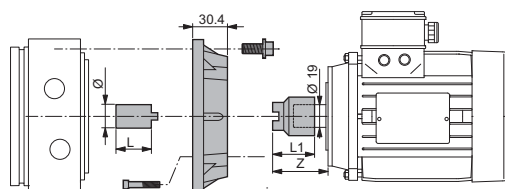

**	Transmission kit						For AC motors		Page
	Code	Pump	L	Ø	L1	Z	Ref.	Size	
1N	KIT01008.007	Gr. 0.5	36.1	14	45.5	63	N	90 (B14)	48 49
	KIT01008.003	Gr. 1	19.5	20	45.5	63			

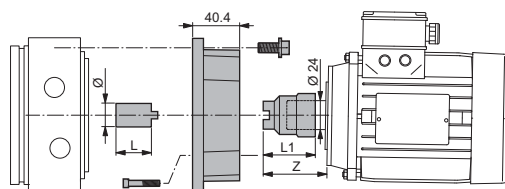

**	Transmission kit						For AC motors		Page
	Code	Pump	L	Ø	L1	Z	Ref.	Size	
1P	KIT01008.013	Gr. 0.5	52.7	14	57	81.5	P	100-112 (B14)	48 49
	KIT01008.004	Gr. 1	36.3	20	57	81.5			

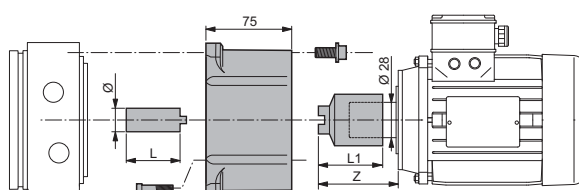

**	Transmission kit				For AC motors		Page
	Code	Pump	L	Ø	Ref.	Size	
1S	KIT01008.130	Gr. 0.5	53.9	14	S	71 (direct fixing)	50
	KIT01008.126	Gr. 1	37.9	14			

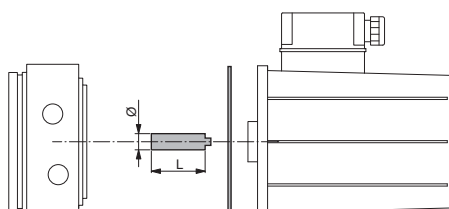

**	Transmission kit				For AC motors		Page
	Code	Pump	L	Ø	Ref.	Size	
1T	KIT01008.131	Gr. 1	41.5	20	T V	80-90 (direct fixing)	51

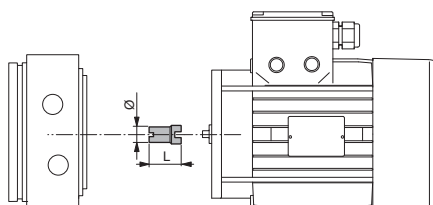

"Z" : dimension of the coupling side motor

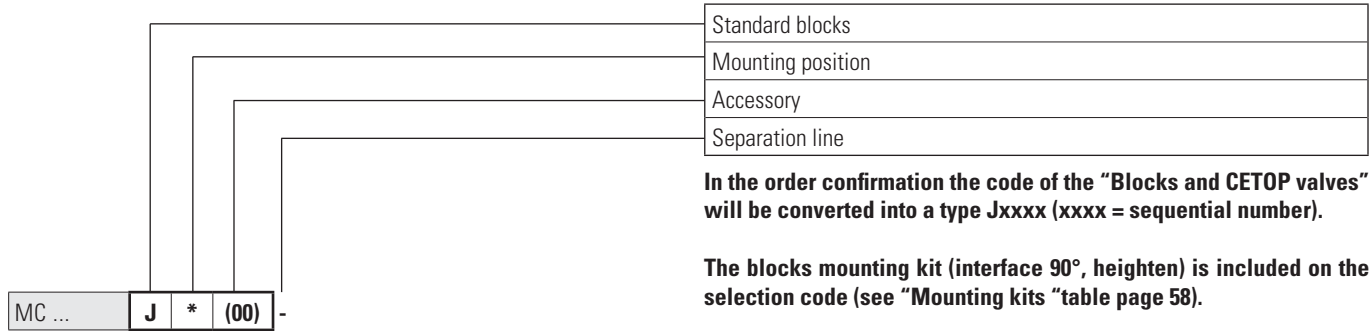

Blocks mounting on horizontal power pack

<p>J 0</p> <p>Blocks orthogonal to the axis Except AC motors ref. size M-N-P</p>	<p>J A</p> <p>Blocks orthogonal to the axis with heighten For AC motors ref. size M-N-P</p>	<p>J B</p> <p>Blocks parallel to the axis with interface 90° Except AC motors ref. size P</p>	<p>J C</p> <p>Blocks parallel to the axis with heighten and interface 90° For AC motors ref. size P</p>
--	---	---	---

The blocks can not be mounted with motors oriented in position "1" (DC motors, see page 46. AC motors, see page 52).

Blocks mounting on vertical power pack

<p>J 0</p> <p>Blocks orthogonal to the axis Except AC motors ref. size M-N-P</p>	<p>J A</p> <p>Blocks orthogonal to the axis with heighten For AC motors ref. size M-N-P</p>	<p>J B</p> <p>Blocks parallel to the axis with interface 90° Except AC motors ref. size P</p>	<p>J C</p> <p>Blocks parallel to the axis with heighten and interface 90° For AC motors ref. size P</p>
--	---	---	---

The blocks can not be mounted with motors oriented in position "1" - DC motors, see page 46. AC motors, see page 52.

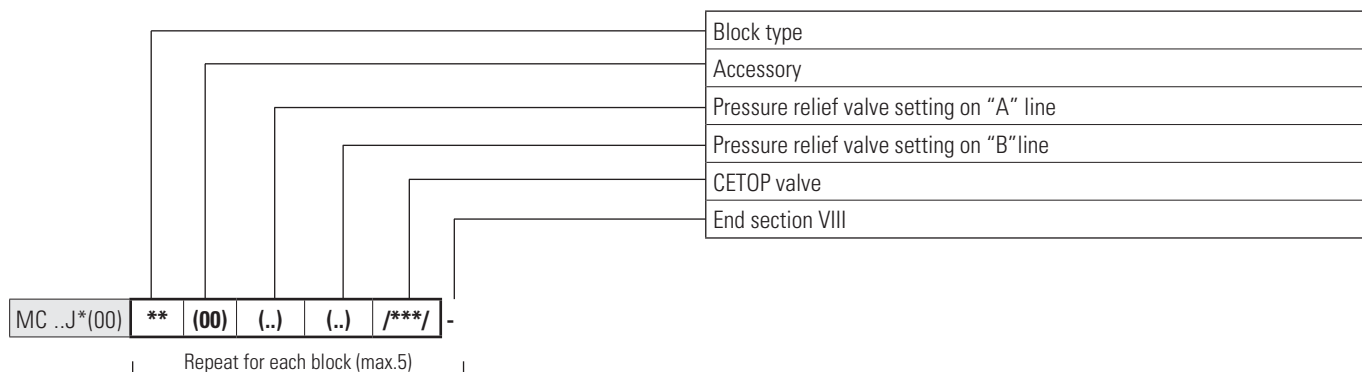

****** (00) (..) (..) /***/ - **Block type**

**	(00)	(..)	(..)	Description	Code	Drawing	Scheme
A1	(00)	(0)	(0)	Middle parallel - Lateral ports G1/4"	91006002.000		
A2	(00)	(0)	(0)	Middle parallel - Lateral ports G3/8"	91006003.000		
B1	(00)	(0)	(0)	Middle series - Lateral ports G1/4"	91006006.000		
B2	(00)	(0)	(0)	Middle series - Lateral ports G3/8"	91006007.000		
C1	(00)	(0)	(0)	End - Lateral ports G1/4"	91006004.000		
C2	(00)	(0)	(0)	End - Lateral ports G3/8"	91006005.000		
D1	(00)	(0)	(0)	With pressure gauge connection - Lateral ports G1/4"	91006008.000		
D2	(00)	(0)	(0)	With pressure gauge connection - Lateral ports G3/8"	91006009.000		

VIII

Sect. VIII - Blocks and CETOP valves

**** (00) (..) (..) /***/ - Block type**

**	(00)	(..)	(..)	Description	Code	Drawing	Scheme
E1	(00)	(0)	(0)	With pilot check valve on "A" port Lateral ports G1/4"	91006010.000		
E2	(00)	(0)	(0)	With pilot check valve on "B" port Lateral ports G1/4"	91006011.000		
E3	(00)	(0)	(0)	With pilot check valve on "A" and "B" ports Lateral ports G1/4"	91006012.000		
F1	(00)	(A)	(0)	With pressure relief valve on "A" port Setting 35 ÷ 90 bar - Lateral ports G1/4"	91006013.000		
		(B)	(0)	With pressure relief valve on "A" port Setting 75 ÷ 190 bar - Lateral ports G1/4"	91006014.000		
		(C)	(0)	With pressure relief valve on "A" port Setting 160 ÷ 290 bar - Lateral ports G1/4"	91006015.000		
F2	(00)	(0)	(A)	With pressure relief valve on "B" port Setting 35 ÷ 90 bar - Lateral ports G1/4"	91006016.000		
		(0)	(B)	With pressure relief valve on "B" port Setting 75 ÷ 190 bar - Lateral ports G1/4"	91006017.000		
		(0)	(C)	With pressure relief valve on "B" port Setting 160 ÷ 290 bar - Lateral ports G1/4"	91006018.000		
F3	(00)	(A)	(A)	With pressure relief valve on "A" and "B" Setting 35 ÷ 90 bar - Lateral ports G1/4"	91006019.000		
		(B)	(B)	With pressure relief valve on "A" and "B" Setting 75 ÷ 190 bar - Lateral ports G1/4"	91006020.000		
		(C)	(C)	With pressure relief valve on "A" and "B" Setting 160 ÷ 290 bar - Lateral ports G1/4"	91006021.000		
G1	(00)	(0)	(0)	Block No.13 (CRP04 valves to be ordered separately, see catalogue code. DOC00044) Lateral ports G1/4"	91006022.000		
K1	(00)	(0)	(0)	End - Hand pump	91006023.000		

Mounting kits

Mounting kit: blocks	For No. blocks	Code
Mounting position 0-B-C	1	17070013
	2	17070015
	3	17070017
	4	17070019
Mounting position A (with heighten)	1	17070014
	2	17070016
	3	17070018
	4	17070020

Mounting kit: interface 90°	Code
Mounting position B	17070022

Mounting kit: interface 90° with heighten	Code
Mounting position C	17070023

The blocks mounting kit (interface 90°, heighten) is included on the selection code (see mounting position, page 55).

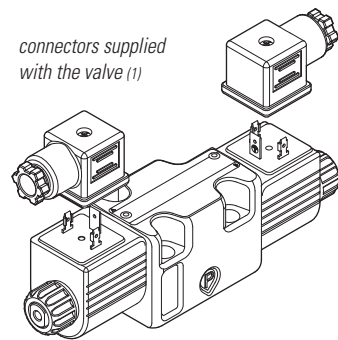

** (00) (..) (..) /***/ - **CETOP 3 valves**

/***/	Voltage	Code	Spool ⁽²⁾		Scheme	Screw kit for valve mounting
			Type	Mounting		
/000/	Without valve					
/001/	24 VDC (M)	ADC3E01CM001	01	C		V60513015
/002/	12 VDC (L)	ADC3E01CL001				
/003/	24 VDC (M)	ADC3E02CM001	02	C		
/004/	12 VDC (L)	ADC3E02CL001				
/005/	24 VDC (M)	ADC3E03CM001	03	C		
/006/	12 VDC (L)	ADC3E03CL001				
/007/	24 VDC (M)	ADC3E04CM001	04	C		
/008/	12 VDC (L)	ADC3E04CL001				

1 = Valves supplied with connector. Without connector see accessories page 59

2 = More details, features and performances, see catalog Dana "Valves and Electronics" code DOC00078

Sect. IX - Accessories

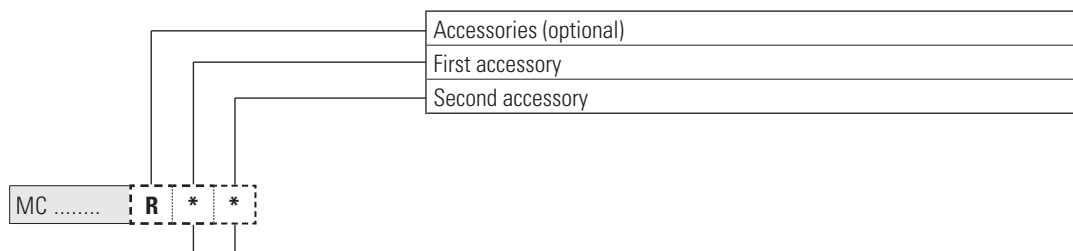

*	Description	Drawing	Code	Note
G	Standard foot, (galvanized sheet steel) thickness 2.5 mm (unassembled)		Kit (foot and screws): 17010021	All motors are compatible except orientation / 3 Tanks compatible (except for orientation / 3) S**A S**B S**C S**G S**L
B	Non-removable red plastic plug for pressure relief valve (unassembled)		Plug: 60309200	
C	Protection device for DC motors (supplied assembled)		Kit (protectin, nut, tierods, washers): 17010048	For motors: M2EN M4ES With blocks, please add the block code 91006000.000
D	High foot, (galvanized sheet steel) thickness 2 mm (unassembled)		Kit (foot and screws): 17010053	All motors are compatible except orientation / 3 Tanks compatible (except for orientation / 3) S**A S**B S**C S**D S**F S**G S**L
E	Collar in welded sheet steel, thickness 2 mm (unassembled)		Collar: 25000300 Tank fixing kit (screws and O-Ring): 17010086	
F	Without valves connectors			

Examples with MCA endhead

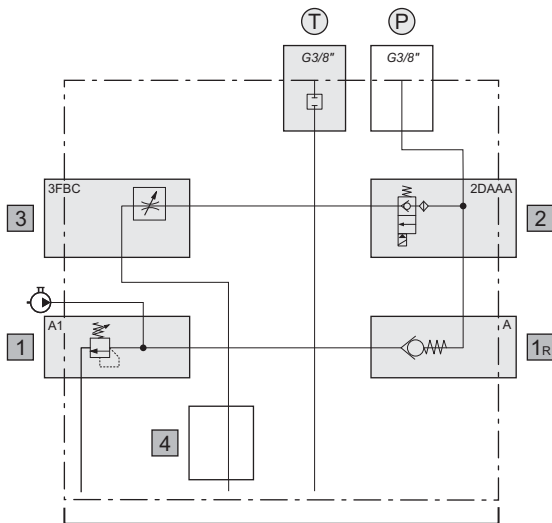

MCA 1 A1 A 2DAAA 3FBC -03 - ..

Cavity	Code	Description	Page
-	1	Thread ports P-T G3/8"	11
1	A1	Pressure relief valve with check valve (15 ÷ 50 bar) with screw and detachable closing, standard setting 50 bar	12
1R	A	Standard check valve	13
2	2DAAA	Piloted solenoid valve normally closed, without emergency. Voltage 12 VDC	15
3	3FBC	Unidirectional flow control valve compensated	18
P-T	-03	Combinations plugs on ports (P= open ; T= closed)	22
-	-	End section	—

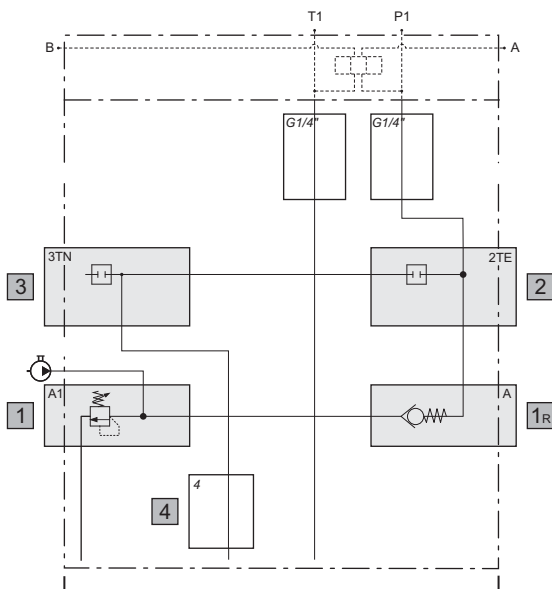

MCA 0 A1 A 2TE 3TN -00 - ..

Cavity	Code	Description	Page
-	0	Thread ports P-T G1/4" (blocks interface)	11
1	A1	Pressure relief valve with check valve (15 ÷ 50 bar) with screw and detachable closing, standard setting 50 bar	12
1R	A	Standard check valve	13
2	2TE	Long plug 3/4 16 UNF - G1/4"	16
3	3TN	Plug	19
P-T	-00	Combinations plugs on ports (P= open ; T= open)	22
-	-	End section	—

Examples with MCB endhead

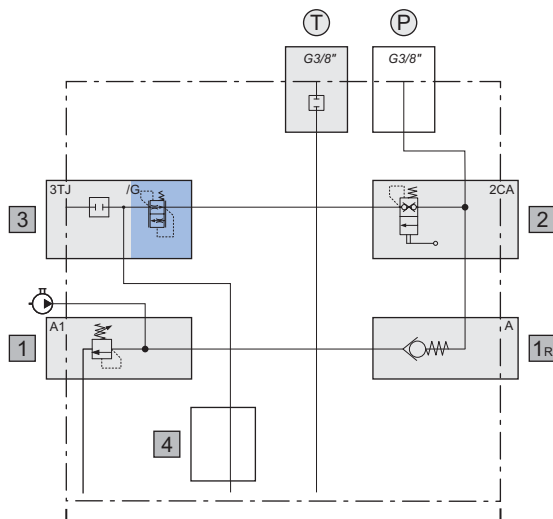

MCB 1 B1(80) A 2CA 3TJ/G -03 - ..

Cavity	Code	Description	Page
-	1	Thread ports P-T G3/8"	11
1	B1	Pressure relief valve with check valve with screw and detachable closing, special setting 80 bar	12
1R	A	Standard check valve	13
2	2CA	Lever operated valve without microswitch	15
3	3TJ/G	Plug and flow control valve 4.7 l/min	20
P-T	-03	Combinations plugs on ports (P= open ; T= closed)	22
-	-	End section	—



BREVINI[®]

Motion Systems

FP HYDRAULIC POWER PACK

Technical Catalogue

June
2019

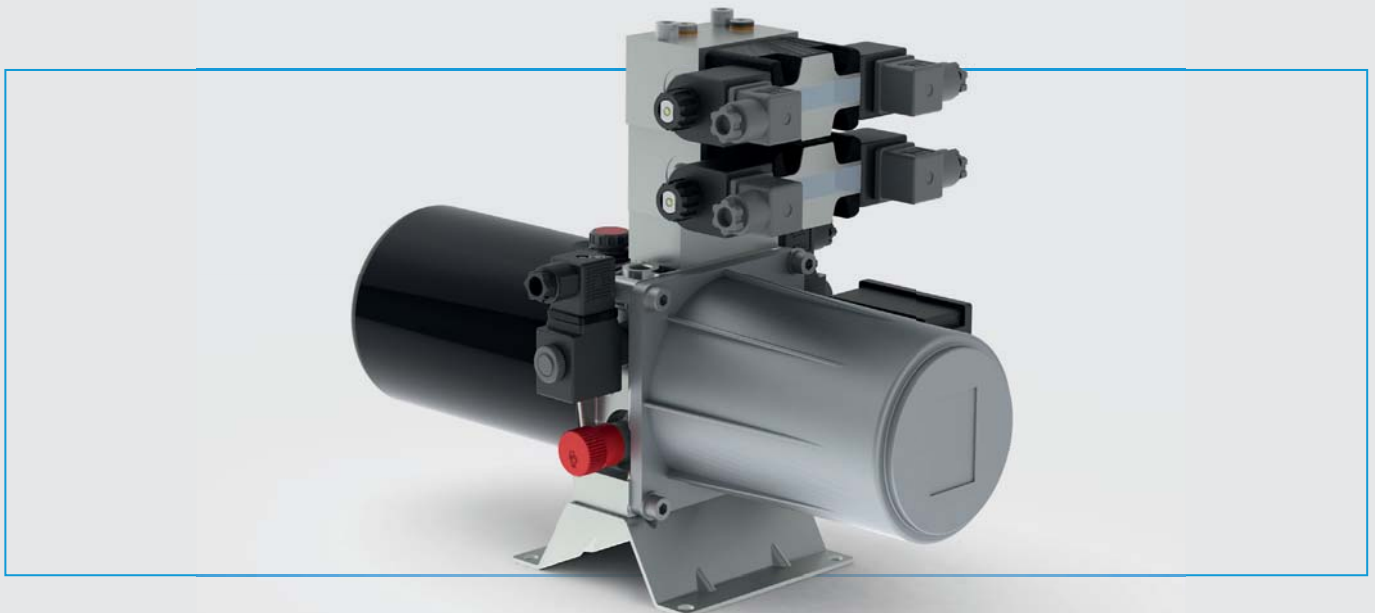



Introduction	2
Endhead configuration	3
Power pack sections	7
Selection code	8
Endhead overall dimensions	11
Cavities dimensions	12
Endhead choice	13

SELECTIONS FOR "FPA" POWER PACK ENDHEAD

Sect. I - FPA Cavity 1	14
Sect. II - FPA Cavity 2	15
Sect. II - FPA Cavity 5	18
Sect. II - FPA Cavity 6-7	19
Sect. II - FPA Ports A-B	20

SELECTIONS FOR "FPC" POWER PACK ENDHEAD

Sect. I - FPC Cavity 1	21
Sect. II - FPC Cavity 2	22
Sect. II - FPC Cavity 3	25
Sect. II - FPC Cavity 4	28
Sect. II - FPC Cavity 5	31
Sect. II - FPC Cavity 6-7-8-9	32
Sect. II - FTC Ports A-B-C	33

SELECTIONS FOR "FPL" POWER PACK ENDHEAD

Sect. I - FPL Cavity 1	34
Sect. II - FPL Cavity 2	35
Sect. II - FPL Cavity 3	38
Sect. II - FPL Cavity 4	41
Sect. II - FPL Cavity 7-8	44
Sect. II - FTL Ports A-B-C-D	45

SELECTIONS FOR "FPE" POWER PACK ENDHEAD

Sect. I - FPE Cavity 1	46
Sect. II - FPE Cavity 2	47
Sect. II - FPE Cavity 3	49
Sect. II - FPE Cavity 9	51
Sect. II - FTE Ports A-B-C-D	52

ELECTIONS FOR ALL POWER PACK ENDHEADS

Sect. III - Pumps	53
Sect. IV - Tanks / Sect. V - Tubes kit	55
Sect. VI - DC Motors	71
Sect. VI - AC Motors	77
Sect. VII - Transmission kit DC motors	83
Sect. VIII - Blocks and CETOP valves	85
Sect. IX - Accessories	89

Examples	90
----------------	----

© 2019 Dana Motion Systems Italia S.r.l. all rights reserved. Hydr-App, SAM Hydraulik, Aron, Brevini Hydraulics, BPE Electronics, VPS Brevini, OT Oiltechnology, logos are trademarks or are registered trademarks of Dana Motion Systems Italia S.r.l. or other companies Dana in Italy and other countries.

The technical features supplied in this catalogue are non binding and no legal action can be taken against such material. Dana will not be held responsible for information and specifications which may lead to error or incorrect interpretations. Given the continuous technical research aimed at improved technical features of our products, Dana reserves the right to make change that are considered appropriate without any prior notice. This catalogue cannot be reproduced (in whole or in part) without the prior written consent of Dana. This catalogue supersedes all previous ones.

Use of the products in this catalogue must comply with the operating limits given in the technical specifications. The type of application and operating conditions must be assessed as normal or in malfunction in order to avoid endangering the safety of people and/or items.

Introduction



The FP series power pack is an easy-to-assemble, compact, electro-hydraulic unit. With its versatility and modularity, it offers many combinations of hydraulic circuits to suit various requirements of plant design. This catalogue has been written to help the user choose the components for the power pack required for the specific application. However, the catalogue cannot foresee all the combinations that may be executed, so in some cases it may be necessary to consult our commercial engineering department.

For applications with very complex circuits, standard modular blocks for Cetop valves and other special blocks can be installed on the power pack, or blocks built to order can be included.

A few applications:

- Fork lifts
- Lifting platforms and beds
- Automotive lifts
- Cranes for small trucks
- Snowplows
- Industrial automation (machine tools, food industry, textile industry)

You can choose from a wide variety of components with the following specifications:

- Gear pumps - Group 0.5 / 1 - from 0.25 to 9.8 cc.
- DC motors, 12/24 V, light-duty service, from 0.35 to 3 Kw
- Single and triple-phase motors with power ratings of up to 4 Kw - in a standard version or built to the customer's specifications (with minimum overall dimensions)
- Tanks in sheet steel with capacities of up to 25 litres
- Tanks in plastic with capacities of up to 10 litres

A fundamental part of the power pack is the endhead, which is made of die-cast aluminum alloy. The parts and dimensions of this component are shown below.

Operating limits

- Intermittent peak pressure: 290 bar (depending on pump type)
- Maximum flow rate: 20 l/min
- Maximum operating temperature:
 - 80°C (with sheet steel tank)
 - 70°C (with polyethylene tank)
 - 60°C (with polypropylene tank)
- Mineral-based hydraulic fluid: ISO 6743-4 (DIN 51524)
 - Minimum viscosity: 12 mm²/s
 - Maximum viscosity: 80 mm²/s
 - Maximum viscosity at start-up: 500 mm²/s
- Minimum ambient temperature -15°C
- Maximum ambient temperature 40°C (with peaks of 50°C)
- The validation of the endhead follows a life-test with 250 bar pulsed pressure repeated for 100.000 cycles



Operating pressure is controlled by the maximum pressure valve and the type of pump used (in terms of performance) may be determined by the maximum pressure valve. Therefore, it is essential not to change the maximum pressure valve. If necessary, contact our technical service department.

Installation

- 1) The power pack must be mounted using the M10 holes on the endhead.
- 2) The power pack must not come into contact with sheet metal, protective guards or any parts that may vibrate and transmit noise.
- 3) The ports on the endhead have been identified by the letters A-B-C. The hydraulic connection must be made with fittings with cylindrical thread and with copper or rubber sealing gaskets (O-rings).
- 4) After the electrical connections have been made, check the direction of motor rotation by executing short pulses of 1 second each (max.): the motor must turn anti-clockwise, as shown in the figure.

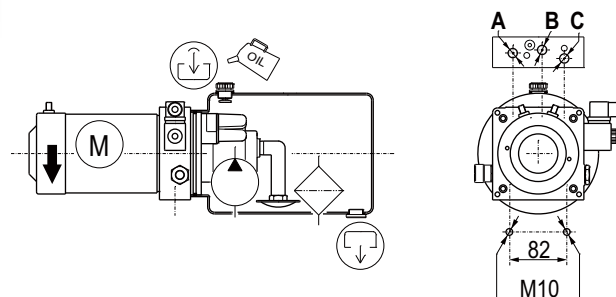

The tank must be filled with new mineral-based, ISO 6743/4 fluid: it is important to filter the fluid while filling the tank.

Symbols used in this catalog:

	Important data/information
	Mounting endhead side
	Ground floor
	Electrical connection boxes on AC motors
	Poles and/or starting relays on DC motors
	Fill plug with breather and level stick
	Fill plug with breather
	Standard plug (closed)
	Standard oil fill plug
	Fill plug with breather
	Fill plug
	Fill plug with check valve
	Fill plug with back check
	Drain plug with magnet
	Plug (or level stick) with visual indicator
	Drain plug
*	Fields to be completed

Power pack endhead configuration

FPA

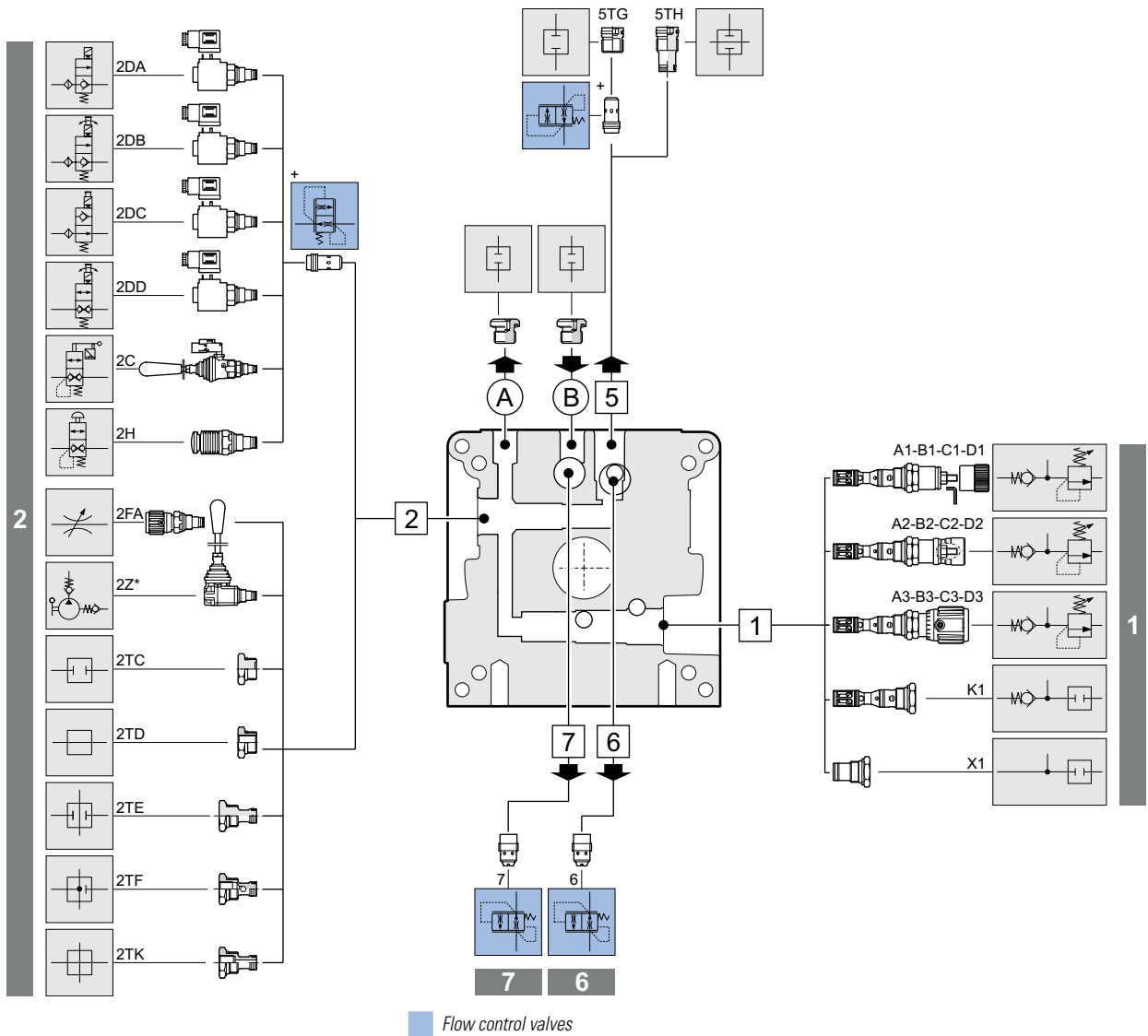

Endhead configuration

i

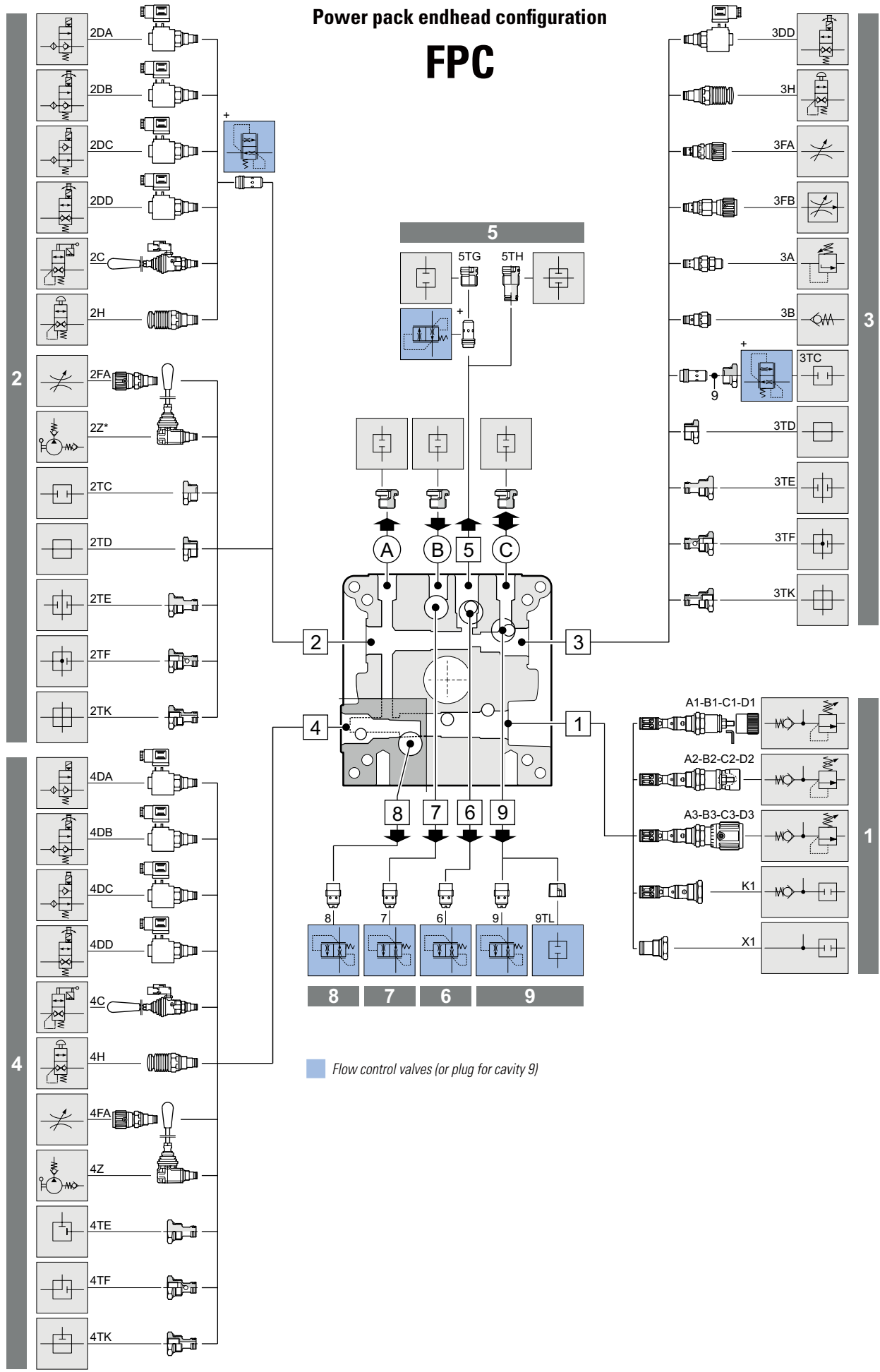

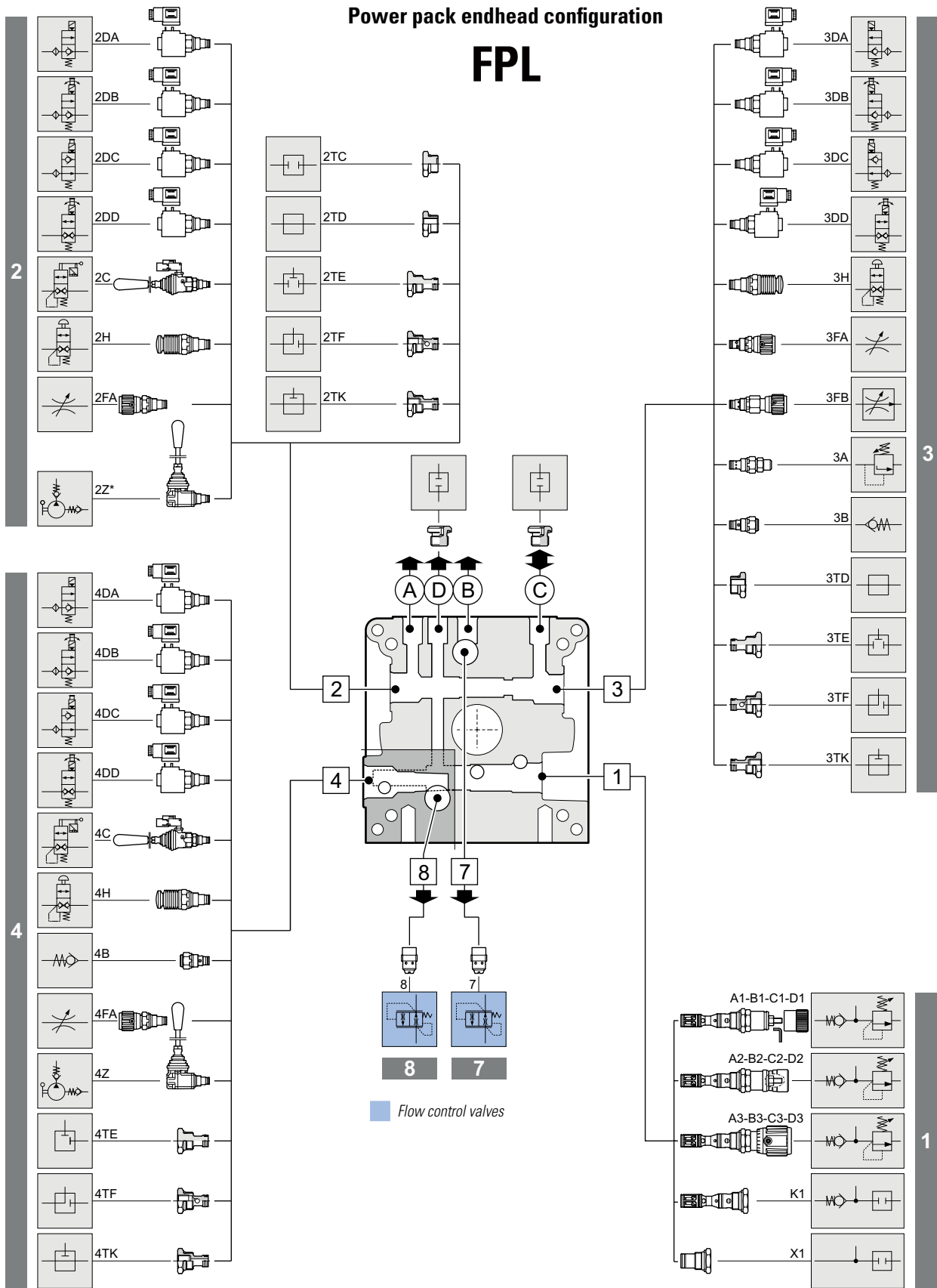

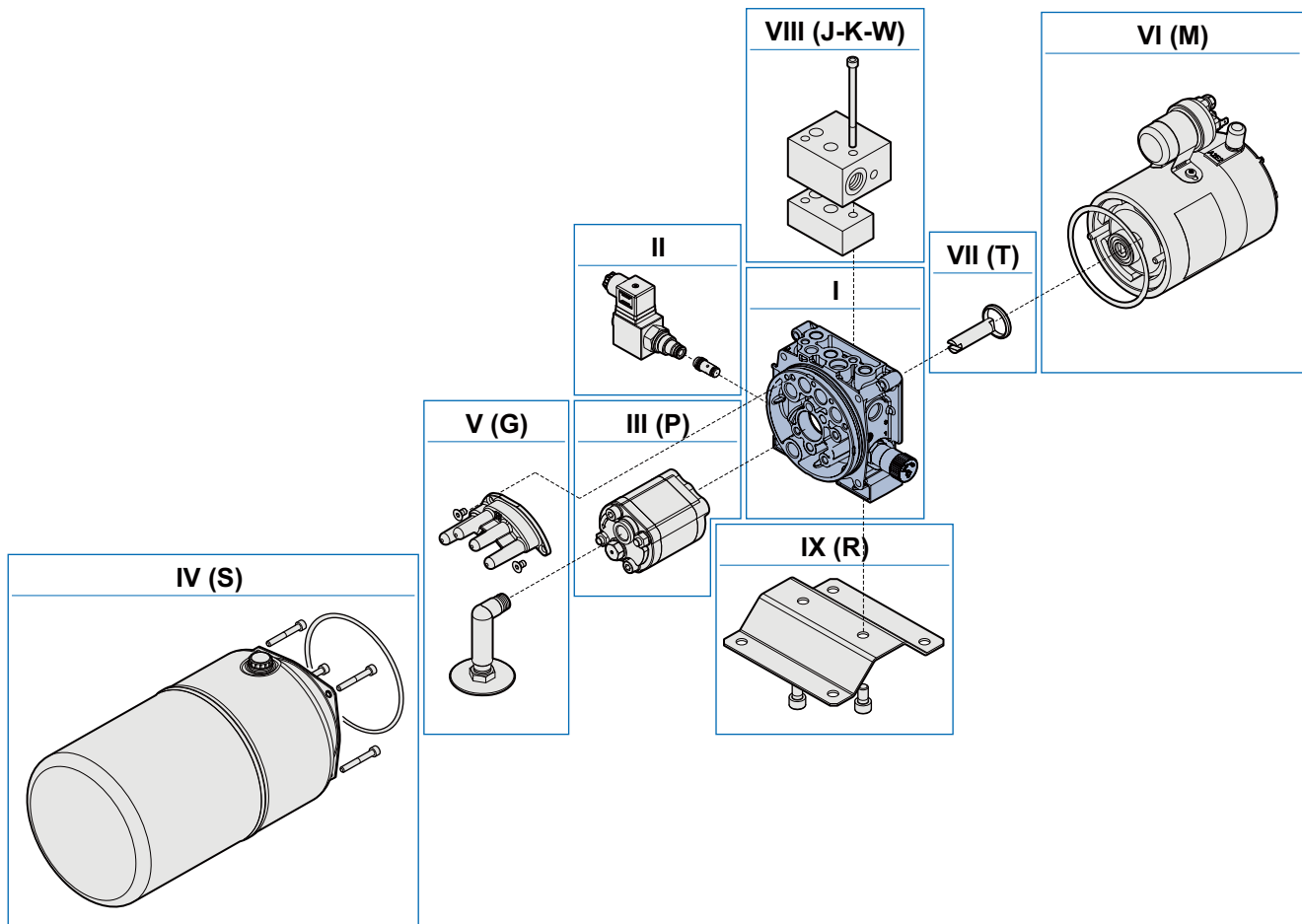

With its great modularity, the FP series of power packs can create multiple configurations which satisfy requirements in a wide range of applications. To make it easier to choose components, the power pack is subdivided into sections.

SECTION I - SERIE, FLANGE TYPE, VALVES ON CAVITY 1

FP Series Powerpacks are based on the Flange features. The Flange is the core of the unit, on the flange are mounted all the valves, the pump, the motor and the reservoir. The FP Flange is available in several Versions (with different tooling options). The Flange Version must be chosen depending on the type of Hydraulic Circuit Layout required. Together with the Flange Version, it is required to select the Valves to be mounted in the Various Cavities. 1 (Main Pressure Relief Valve).

SECTION II - VALVES

Depending on the Type of Hydraulic Circuit Layout to be realized, it is required to Select the Valves for each of the available Cavities. In order to correctly build up the Ordering Code, it is required to use the following procedure. Peripheral Cavities (it is mandatory to mention all the Cavities in Numeral Order): starting from Cavity 2, mention all the Cavities and the Valves, Plugs or Fittings to be mounted in said Cavity. Internal Cavities: normally connected to Tank (It is not mandatory to mention, but if required it should be done in Numeral Order): starting from Cavity 6, mention all the Internal Cavities where a Valve (usually a Return Line Valve) is mounted, Selecting the Valve Type to be mounted in said Cavity. Outputs, see description in the Table.

SECTION III - PUMPS

It is mandatory to mention this section, defined by the letter P. Depending on the required features, select the pump from the table provided.

SECTION IV - TANKS

This section is defined by the letter S. Depending on the required features, select the reservoir from the list provided. If no Reservoir is required, and also no Suction / Return Kit is required, please omit this section. If no Reservoir is required, but a Suction / Return Kit is required, please jump to Section V (defined by letter G).

SECTION V - TUBES KIT (suction and return, only for tanks on the catalog)

This section is defined by the letter G. In order to define this Section, please select the Reservoir Type anyways.

SECTION VI - MOTORS

This section is defined by the letter M. Depending on the Type of Hydraulic Circuit Layout to be realized, it is required to Select the Motor Type. If no Motor is required, and no Transmission Kit is required, please omit this section. If no Motor is required, but a Transmission Kit is required, please jump to Section VII (defined by letter T).

SECTION VII - TRANSMISSION KIT (only for motors on the catalog)

This section is defined by the letter T. Select the kit as per Table provided.

SECTION VIII - BLOCKS

This section it is not mandatory, depending on the Type of auxiliary Block required, definition Letter changes: J, Blocks with CETOP type of interface for Solenoid Valves; K, Bankable Valves Interface – Horizontal (Parallel to Unit Axis); W, Bankable Valves Interface – Vertical (Perpendicular to Unit Axis);

SECTION IX - ACCESSORIES

This section it is not mandatory, is defined by the letter R. Check the available options in the list provided. Accessories must be listed in Alphabetical Order.

Selection code

SECTION I - SERIE, ENDHEAD, VALVES ON CAVITY 1

i

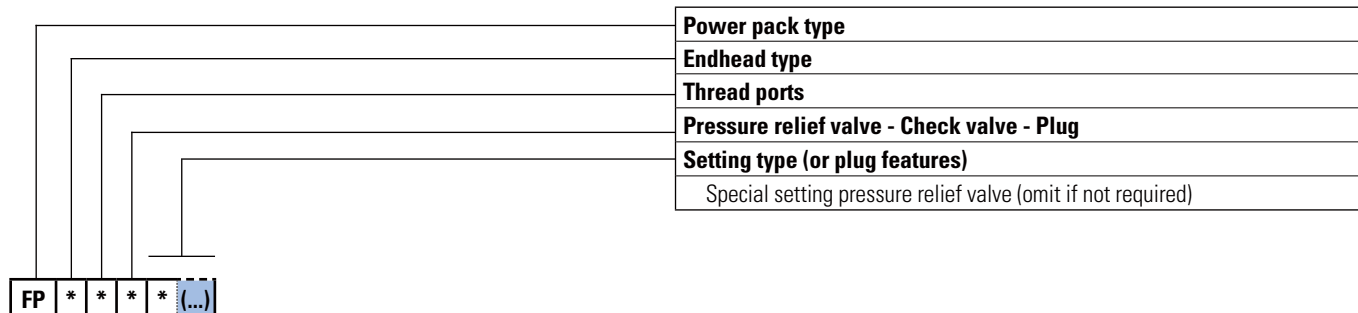

SECTION II - VALVES

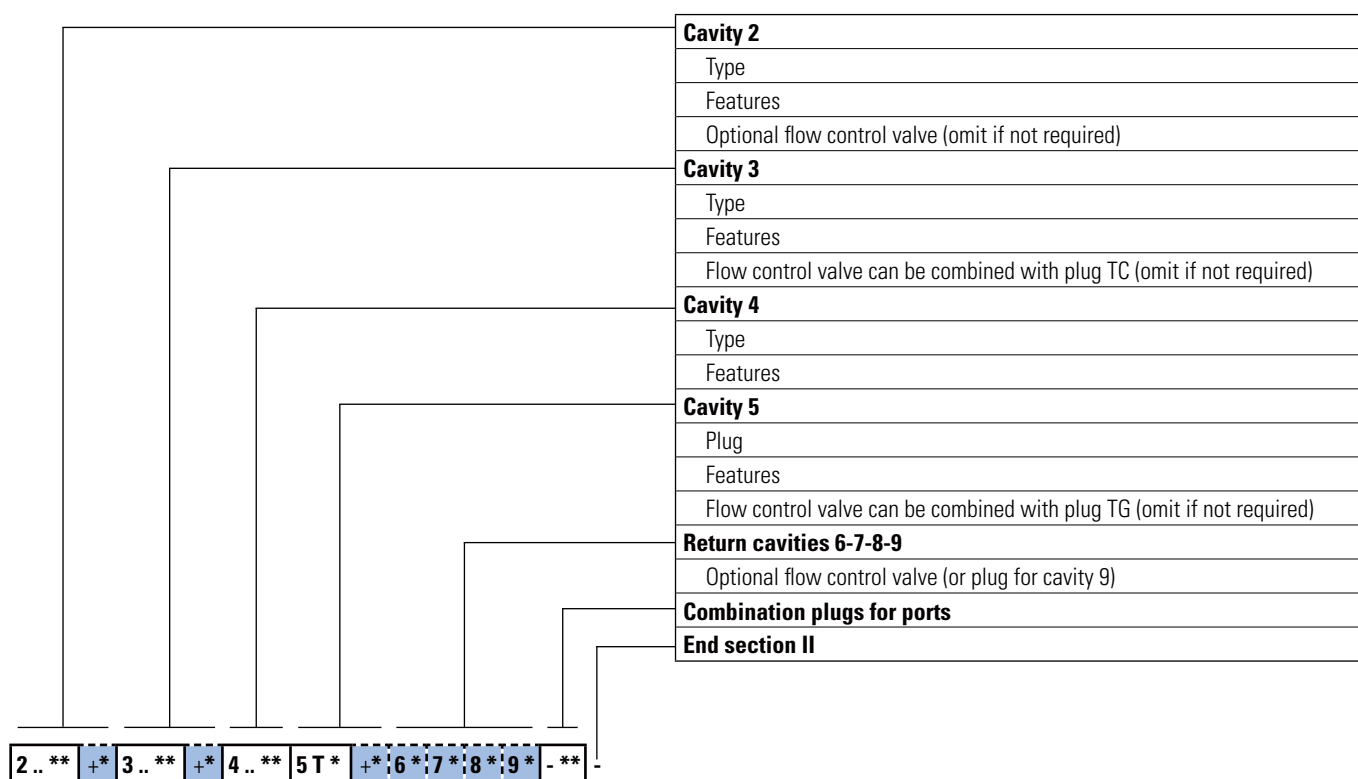

SECTION III - PUMPS

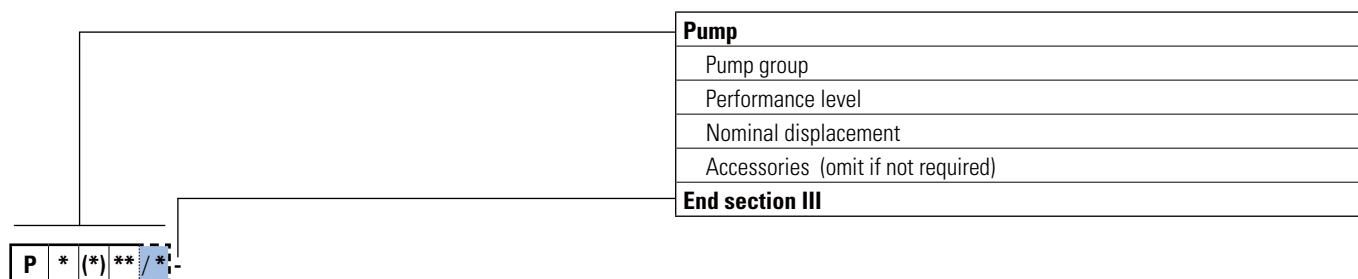

Selection code

SECTION IV - TANKS / SECTION V - TUBES KIT

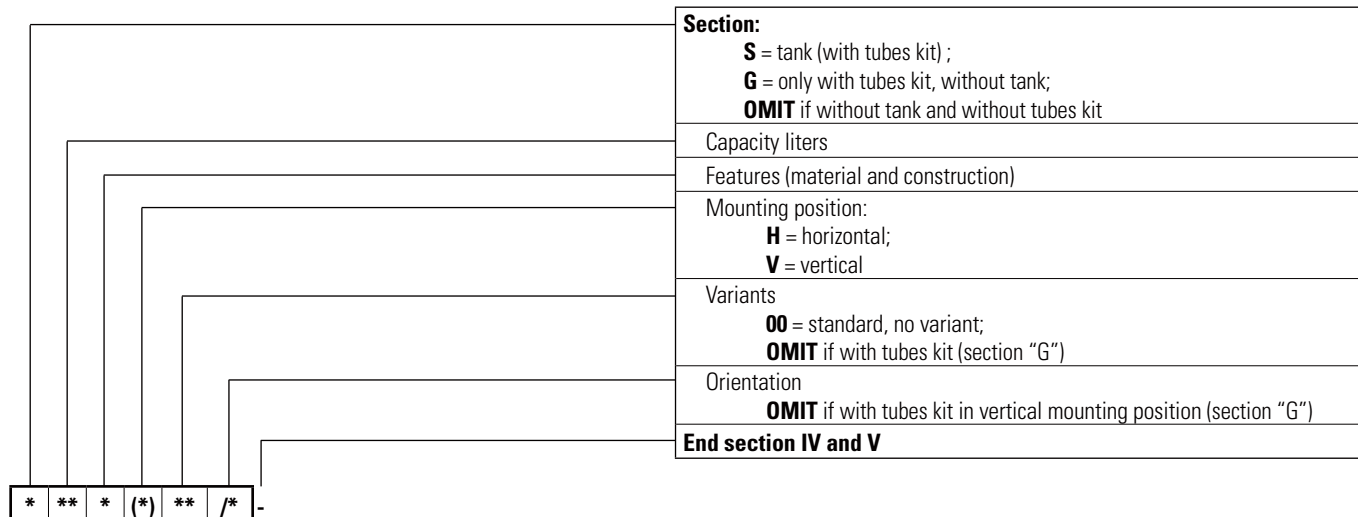

SECTION VI - MOTORS

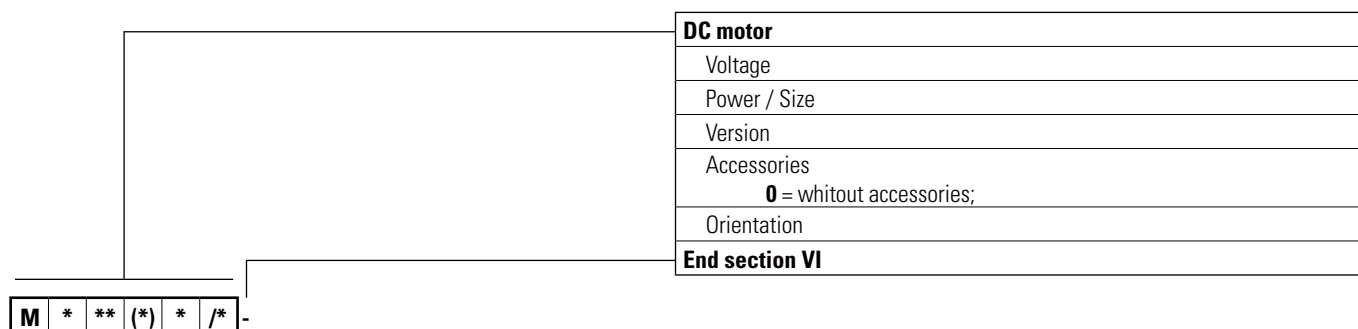

OR ..

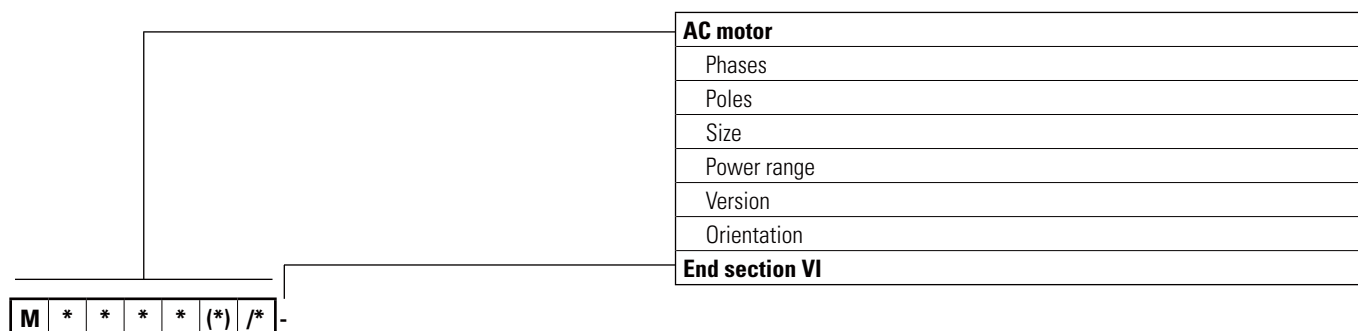

Selection code

SECTION VII - TRANSMISSION KIT (only for motors on the catalog)

i

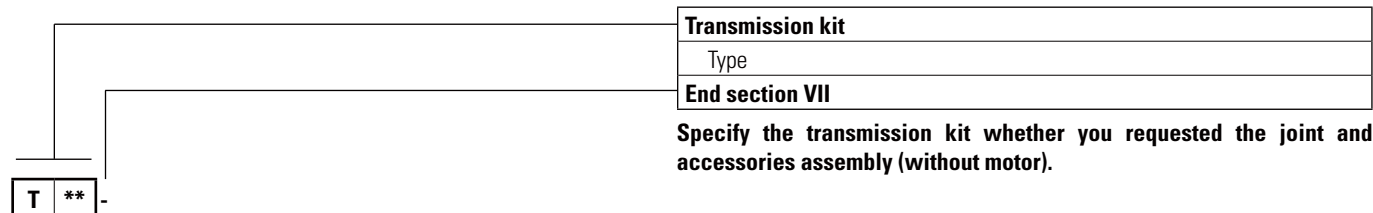

SECTION VIII - BLOCKS

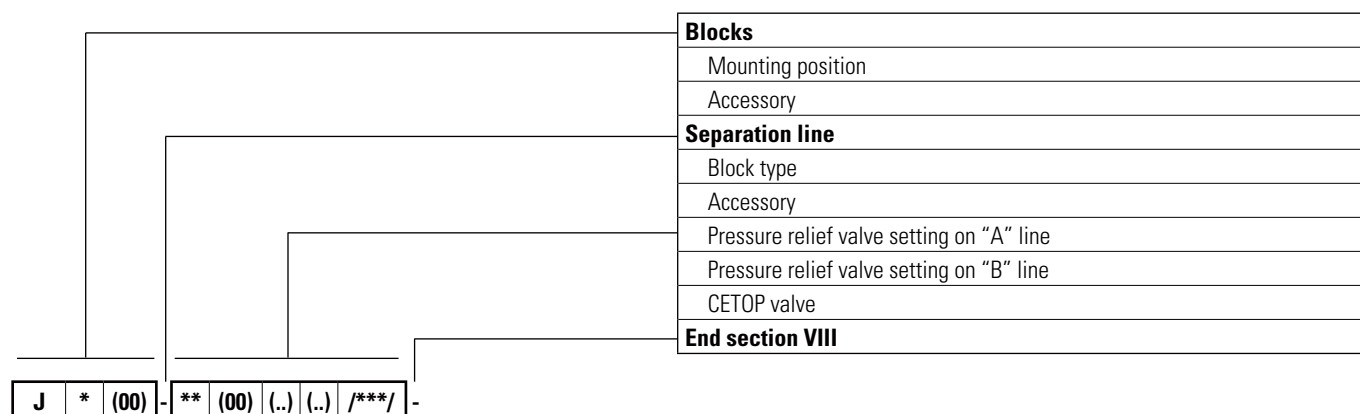

SECTION IX - ACCESSORIES

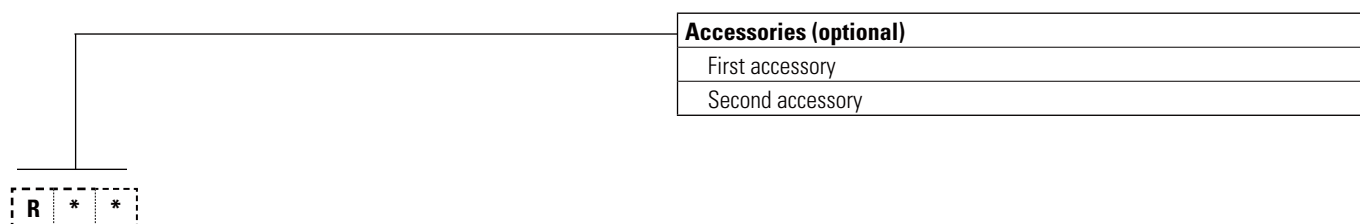

Endhead overall dimensions

Cavities on endhead:

Cavity	Thread	Endhead type				
		FPA	FPC	FPL	FPE	
A	Ports	G1/4" (1)	•	•	•	•
		G3/8" (2)	•	•	•	•
B	Ports	G1/4" (1)	•	•	•	•
		G3/8" (2)	•	•	•	•
C	Ports	G1/4" (1)	—	•	•	•
		G3/8" (2)	—	•	•	•
D	Ports	G1/4" (1)	—	—	•	•
1	Peripheral	3/4" 16 UNF	•	•	•	•
2	Peripheral	3/4" 16 UNF	•	•	•	•
3	Peripheral	3/4" 16 UNF	—	•	•	•
4	Peripheral	3/4" 16 UNF	—	•	•	—
5	Peripheral (3)	M16x1.5	•	•	—	—
6	Return	G3/8"	•	•	—	—
7	Return	G3/8"	•	•	•	—
8	Return	G3/8"	—	•	•	—
9	Return	G3/8"	—	•	—	•

1) blocks interface

2) available only for FPA - FPC endhead

3) the cavity 5 is not accessible with blocks mounted (section IX).

The number of cavities tooled identify the endhead type:

There are three types of cavities:

- **Peripheral cavities**, which can be accessed externally
- **Return cavities**, inside of the tank.
- **Ports**

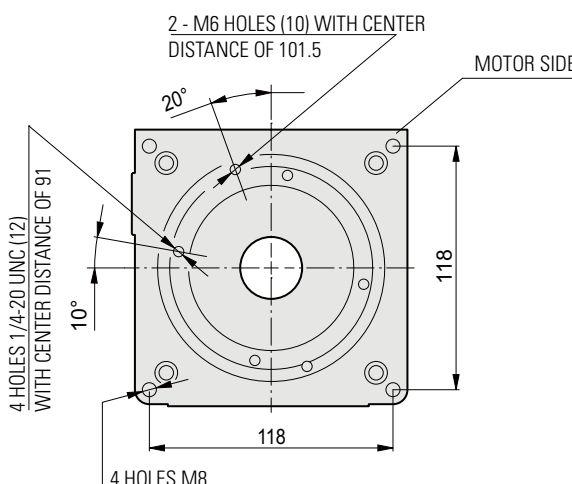
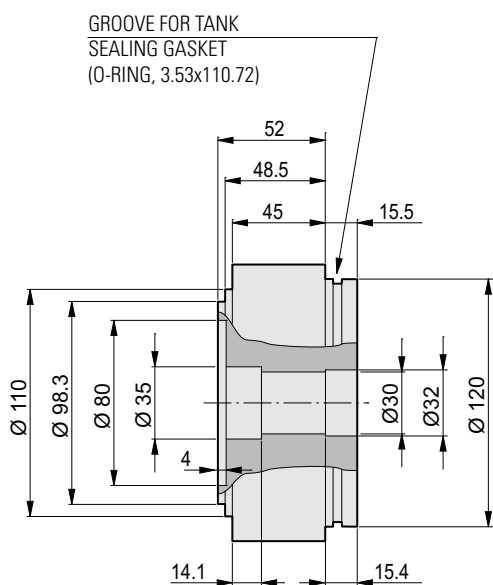
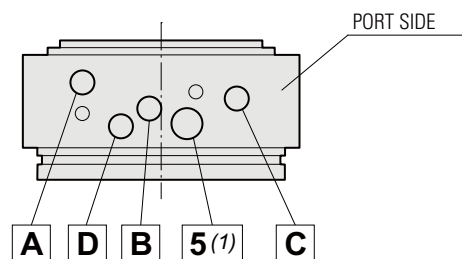
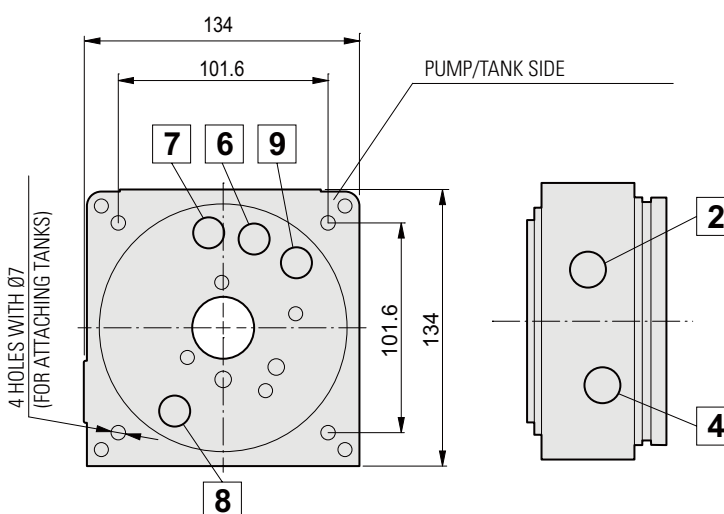
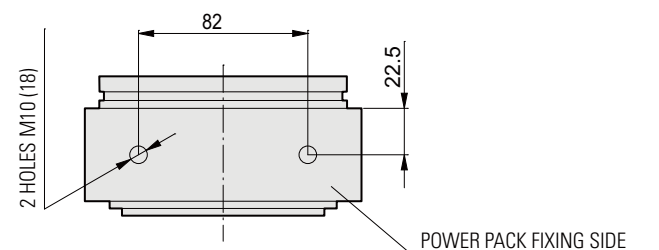
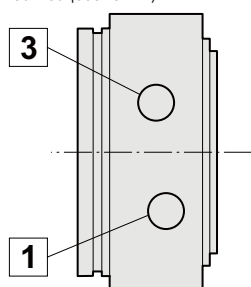

The cavities (1-2-3-4-5) and the ports (A-B-C) are marked on the die-cast endhead. The dimensions on the drawing are the same for all endhead.

Cavities dimensions



i

Cavity		Thread	Drawing	Cavity		Filettatura	Drawing
1	Peripheral	3/4 16 UNF	<p>CD018013</p>	5	Peripheral	M16 x 1.5	
2	Peripheral (FPA-FPC)	3/4 16 UNF	<p>CD018009</p>	6	Return	G 3/8	
2	Peripheral (FPE)	3/4 16 UNF	<p>CD018001</p>	7	Return	G 3/8	
3	Peripheral	3/4 16 UNF	<p>CD018014</p>	8	Return	G 3/8	
4	Peripheral	3/4 16 UNF	<p>CD018014</p>	9	Return	G 3/8	

Endhead choice

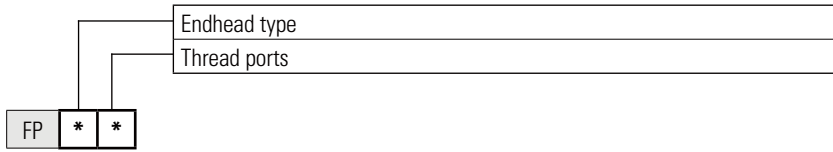

FP

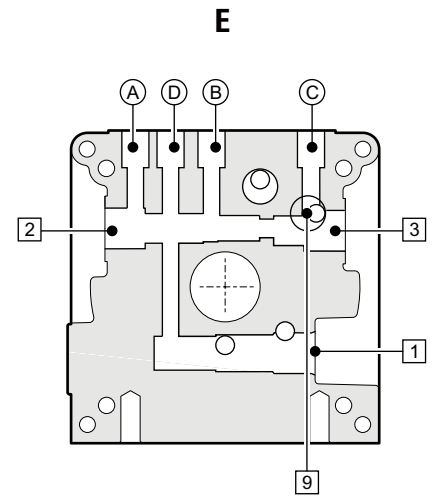
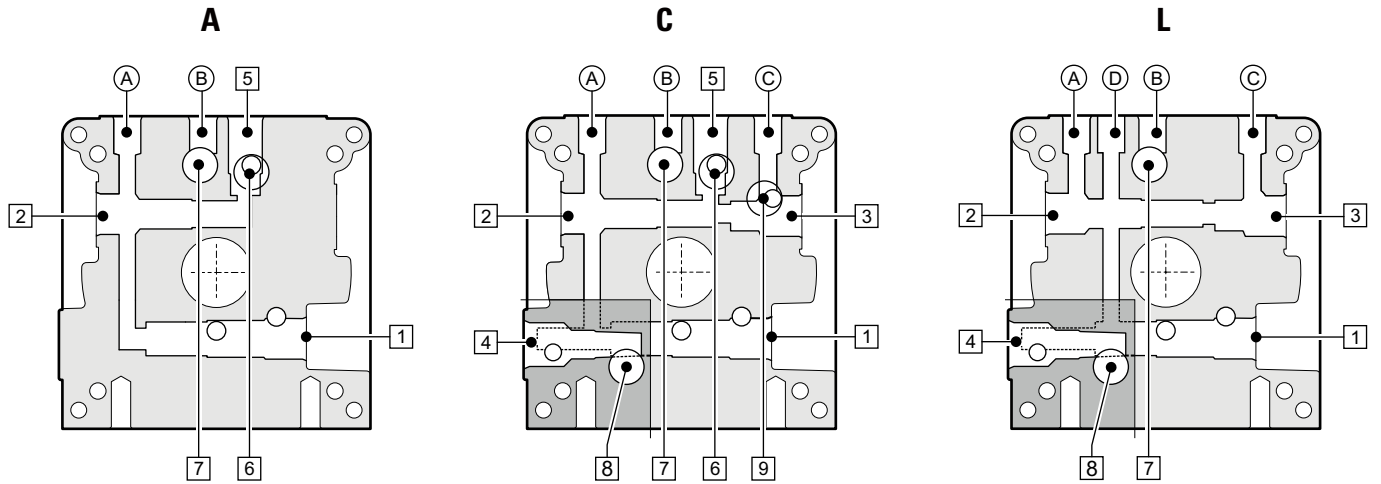

***** *Endhead type*

*	Ports	Peripheral	Return
A	n. 2 (A - B)	n. 3 (1 - 2 - 5)	n. 2 (6 - 7)
C	n. 3 (A - B - C)	n. 5 (1 - 2 - 3 - 4 - 5)	n. 4 (6 - 7 - 8 - 9)
L	n. 4 (A - B - C - D)	n. 4 (1 - 2 - 3 - 4)	n. 2 (7 - 8)
E	n. 4 (A - B - C - D)	n. 3 (1 - 2 - 3)	n. 1 (9)

***** *Thread ports*

*	Ports thread		Blocks interface
	G1/4"	G3/8"	
0	YES		YES
1		YES	NO

	Endhead codes	
	G1/4"	G3/8"
FPA	78013010.000	78013011.000
FPC	78013014.000	78013015.000
FPL	78013022.000	
FPE	78013016.000	

Sect. I - FPA Cavity 1

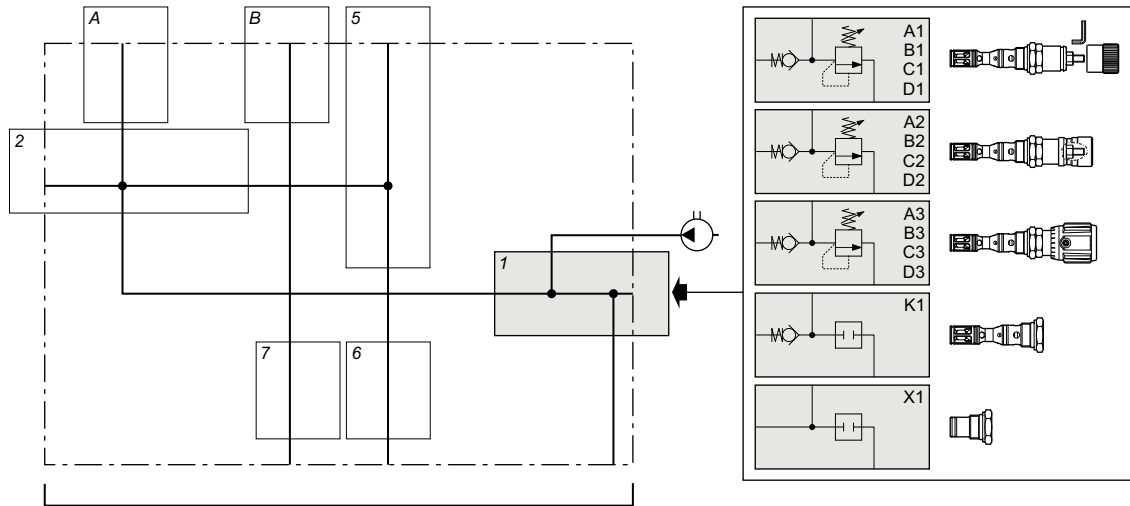
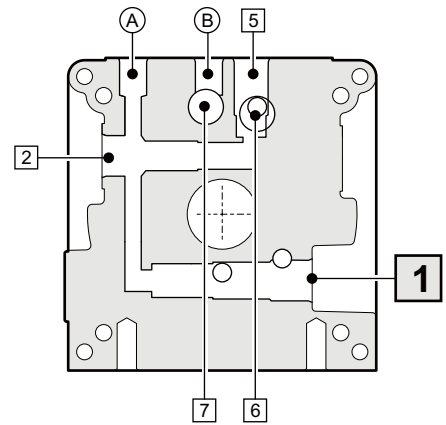
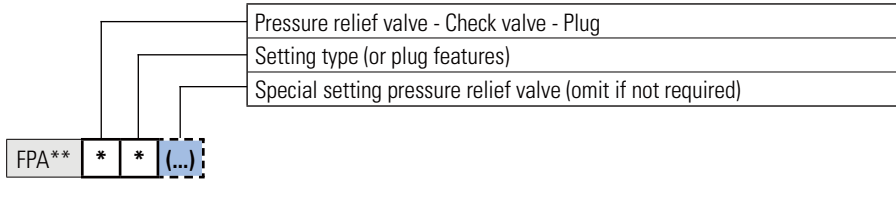

* * (...) Pressure relief valve with check valve

*	*	Pressure (bar)	STD setting (bar)	(...) Special setting (bar)	Setting type	Code	Symbol	Drawing
D	1	15 ÷ 50	30	15 ÷ 50 (5 to 5)	Detachable closing	CMPR04S00002		
	2				Non removable closing (1)	CMPR04P00002		
	3				Plastic knob	CMPR04M00002		
E	1	35 ÷ 110	50	35 ÷ 110 (5 to 5)	Detachable closing	CMPR04S01002		
	2				Non removable closing (1)	CMPR04P01002		
	3				Plastic knob	CMPR04M01002		
F	1	75 ÷ 220	150	75 ÷ 220 (5 to 5)	Detachable closing	CMPR04S02002		
	2				Non removable closing (1)	CMPR04P02002		
	3				Plastic knob	CMPR04M02002		
G	1	160 ÷ 290	180	160 ÷ 290 (10 to 10)	Detachable closing	CMPR04S03002		
	2				Non removable closing (1)	CMPR04P03002		
	3				Plastic knob	CMPR04M03002		

1 = Supplied assembled. Unassembled, see accessories page 89

* * Check valve and plug

*	*	Description	Code	Symbol	Drawing
K	1	Check valve - Opening pressure 0.5 bar	CR10400001		
X	1	Plug	R78150100		

Sect. II - FPA Cavity 2



Cavity
Type
Features
Optional flow control valve (omit if not required)

FPA** ** (...) **2** .. ** **+***

	2DA**		
	2DB**		
	2DC**		
	2DD**		
	2C*		
	2H*		
	2FA*		
	2Z*		
	2TC		
	2TD		
	G 1/4		
	2TE		
	2TF		
	G 1/4		
	2TK		
	G 1/4		

Flow control valves

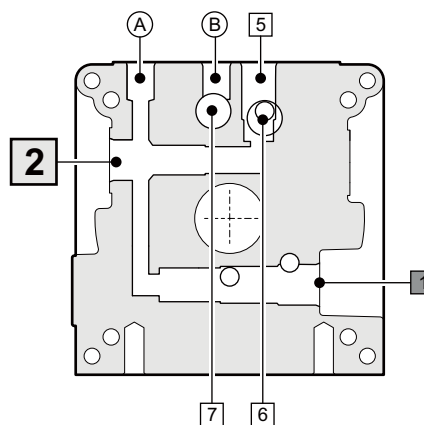
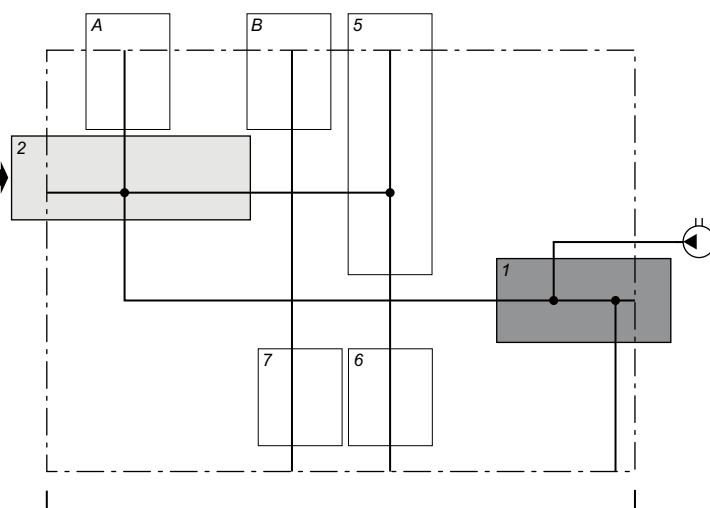

II
FPA

2 DA ** +* *Piloted solenoid valves normally closed, without emergency (1)*

**	Description	Code (valve + connector)	Symbol	Drawing
AA	Voltage 12 Vdc	CRP0418NCASL003 + V86050002		
AB	Voltage 24 Vdc	CRP0418NCASM003 + V86050002		
AC	Voltage 24 Vac 50 Hz	CRP0418NCASA003 + V86050002		
AD	Voltage 115 Vac 50 Hz	CRP0418NCASJ003 + V86050002		
AE	Voltage 230 Vac 50 Hz	CRP0418NCASI003 + V86050002		

2 DB ** +* *Piloted solenoid valves normally open, with rotary emergency (1)*

**	Description	Code (valve + connector)	Symbol	Drawing
AA	Voltage 12 Vdc	CRP0418NCAEL003 + V86050002		
AB	Voltage 24 Vdc	CRP0418NCAEM003 + V86050002		
AC	Voltage 24 Vac 50 Hz	CRP0418NCAEA003 + V86050002		
AD	Voltage 115 Vac 50 Hz	CRP0418NCAEJ003 + V86050002		
AE	Voltage 230 Vac 50 Hz	CRP0418NCAEI003 + V86050002		

2 DC ** +* *Piloted solenoid valves normally open, with button emergency (1)*

**	Description	Code (valve + connector)	Symbol	Drawing
AA	Voltage 12 Vdc	CRP0418NAAEL003 + V86050002		
AB	Voltage 24 Vdc	CRP0418NAAEM003 + V86050002		
AC	Voltage 24 Vac 50/60 Hz (RAC with rectifier)	CRP0418NAAE2003 + V86200002		
AD	Voltage 115 Vac 50 - 120 Vac 60 Hz (RAC with rectifier)	CRP0418NAAEZ003 + V86200002		
AE	Voltage 230 Vac 50 - 240 Vac 60 Hz (RAC with rectifier)	CRP0418NAAEX003 + V86200002		
AF	Voltage 48 Vdc	CRP0418NAAEN003 + V86050002		

2 DD ** +* *Direct operated solenoid valve normally closed, with button emergency (1)*

**	Description	Code (valve + connector)	Symbol	Drawing
AA	Voltage 12 Vdc	CRD0418NCAEL002 + V86050002		
AB	Voltage 24 Vdc	CRD0418NCAEM002 + V86050002		

2 C * +* *Lever operated valve*

*	Description	Code	Symbol	Drawing
A	Without microswitch	CMF04L001		
B	With microswitch	CMF04M001		

1 = Valves supplied with connector. Without connector see accessories page 89

2 H * ^{+*} Button operated valves

**	Description	Code	Symbol	Drawing
A	Push-button control	CPE04P000.1		

2 .. ** ^{+*} Flow control valves ⁽¹⁾

*	Flow	Code	Symbol	Drawing
+B	1.4 l/min	VSC040101		
+C	2.3 l/min	VSC040201		
+E	2.8 l/min	VSC040301		
+G	4.3 l/min	VSC040401		
+J	5.2 l/min	VSC040601		
+L	6.5 l/min	VSC040801		
+N	8.0 l/min	VSC041101		
+Q	11.1 l/min	VSC041601		

(1) The flow control valves can be installed with solenoid valves, with manual controls and with push-button valves.

2 FA * Bidirectional flow control valves not compensated

*	Description	Code	Symbol	Drawing
A	Screw adjustment	CSB04C0000		
B	Plastic knob adjustment	CSB04V0000		

2 Z * Hand pumps

*	Description	Code	Symbol	Drawing
A	Cilindrata 1 cc	CPM0410001		
B	Cilindrata 2 cc	CPM0420001		

2 T * Plugs and fittings

*	Description	Code	Symbol	Drawing
C	Plug 3/4 16 UNF	R78150099		
D	Fitting 3/4 16 UNF - G1/4	20001700		
E	Long plug 3/4 16 UNF	20003800		
F	Fitting 3/4 16 UNF - G1/4	20009400		
K	Fitting 3/4 16 UNF DIN - G1/4	20018000		

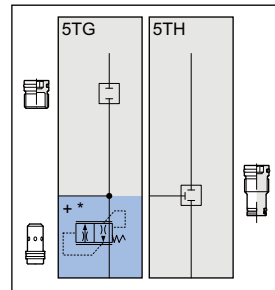
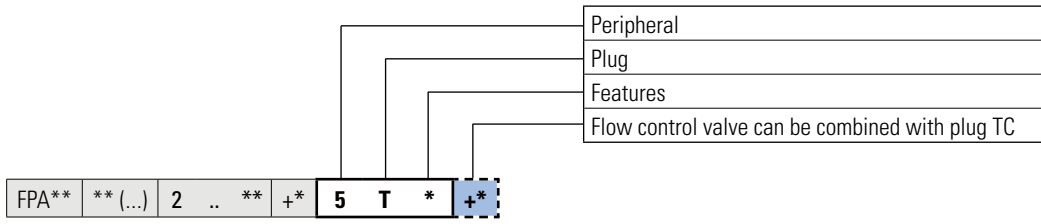

Flow control valves

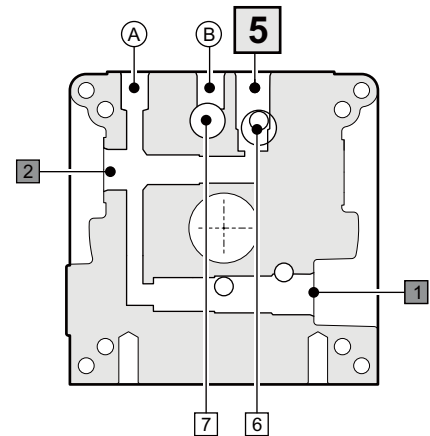
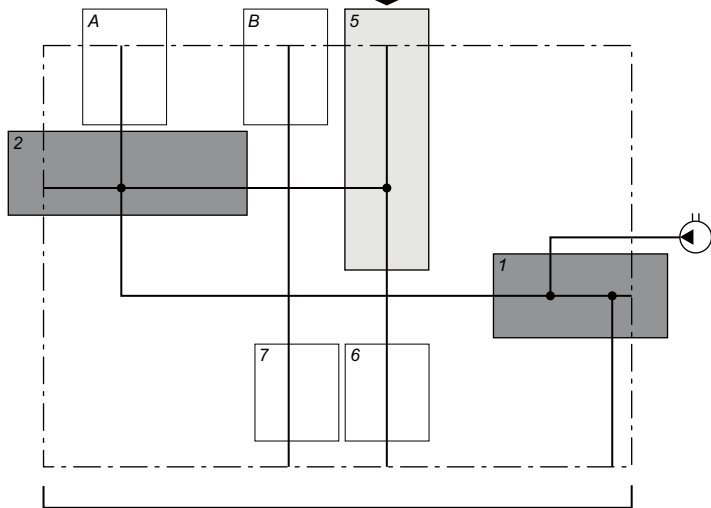

5 T * +* Plugs

**	Description	Code	Symbol	Drawing
G	Plug M16x1.5 (1)	R78150104		
H	Long plug M16x1.5	R78150101		

2 .. ** +* Flow control valves (1)

*	Flow	Code	Symbol	Drawing
+B	1.4 l/min	VSC040101		
+C	2.3 l/min	VSC040201		
+E	2.8 l/min	VSC040301		
+G	4.3 l/min	VSC040401		
+J	5.2 l/min	VSC040601		
+L	6.5 l/min	VSC040801		
+N	8.0 l/min	VSC041101		
+Q	11.1 l/min	VSC041601		

(1) Flow control valves can be combined with plug TG.

Sect. II - FPA Cavity 6-7

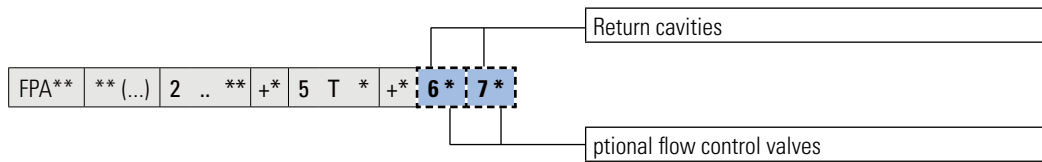

Return cavity, omit if not required flow control valves

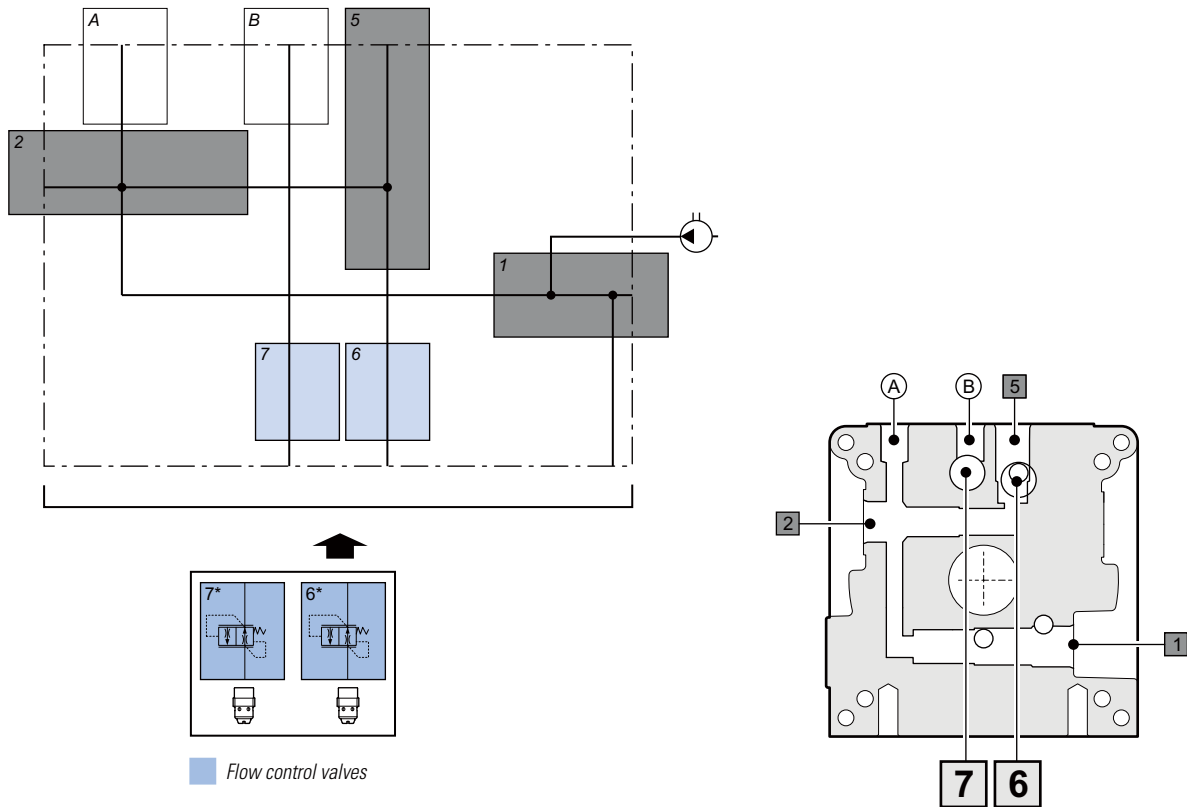

II
FPA

6* 7* Flow control valves for return cavities "6-7"

* 6 7	*	Nominal flow at 120 bar	Code	Symbol	Drawing
	A	0.7 l/min	VSC06100002		
	B	1.1 l/min	VSC06120002		
	C	2.1 l/min	VSC06130002		
	E	3.2 l/min	VSC06150002		
	G	4.7 l/min	VSC06190002		
	K	6.3 l/min	VSC06220002		
	N	7.5 l/min	VSC06240002		
	Q	10.0 l/min	VSC06280002		
	U	13.2 l/min	VSC06330002		
	V	15.7 l/min	VSC06350002		

Possible combinations plugs on ports
End section II

FPA** ** (...) 2 .. ** +* 5 T * +* 6* 7* -**

II
FPA

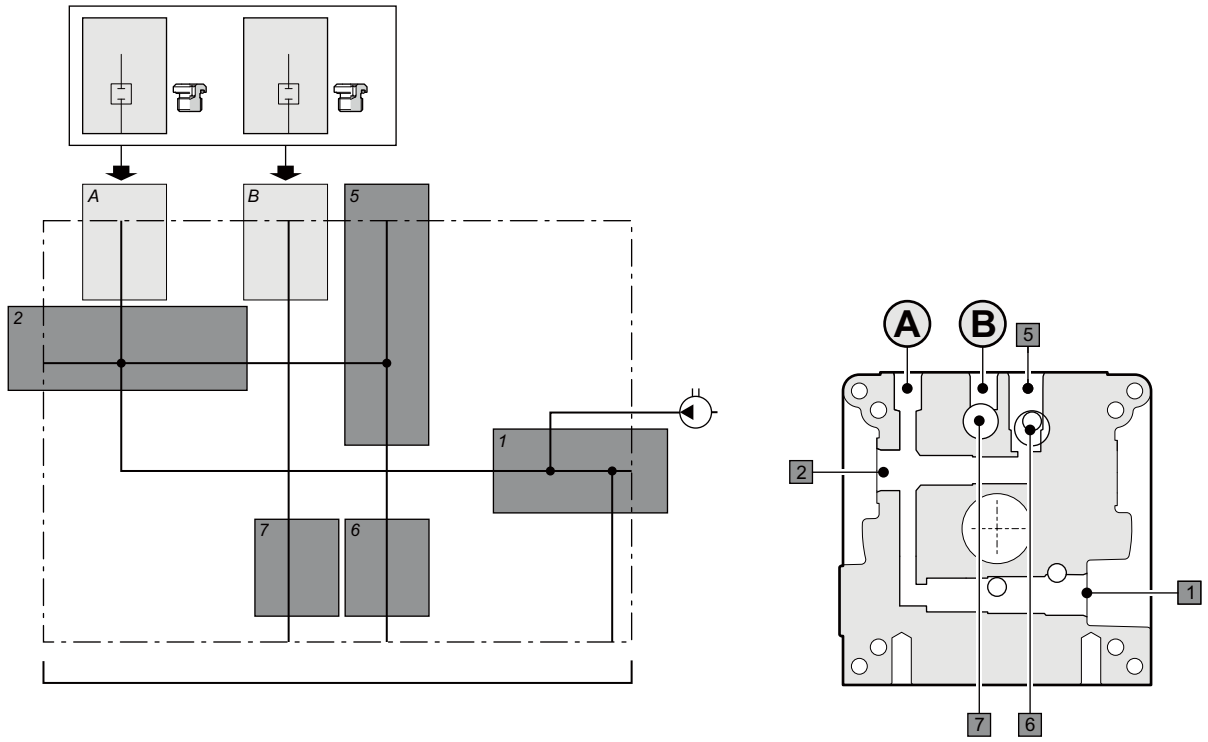

- Combinations plugs on ports A-B**

-**	P	T
-00	↑	↑
-02	⊗	↑
-03	↑	⊗
-06	⊗	⊗

Combination -00 to use with the standard blocks (page 85)

Symbols description

Type	Description	Thread	Code	Symbol	Drawing
⊗	Port closed with plug	G 1/4"	20024000		
		G 3/8"	Q26622255 (plug whit OR)		
↑	Port open		—	—	—

Sect. I - FPC Cavity 1

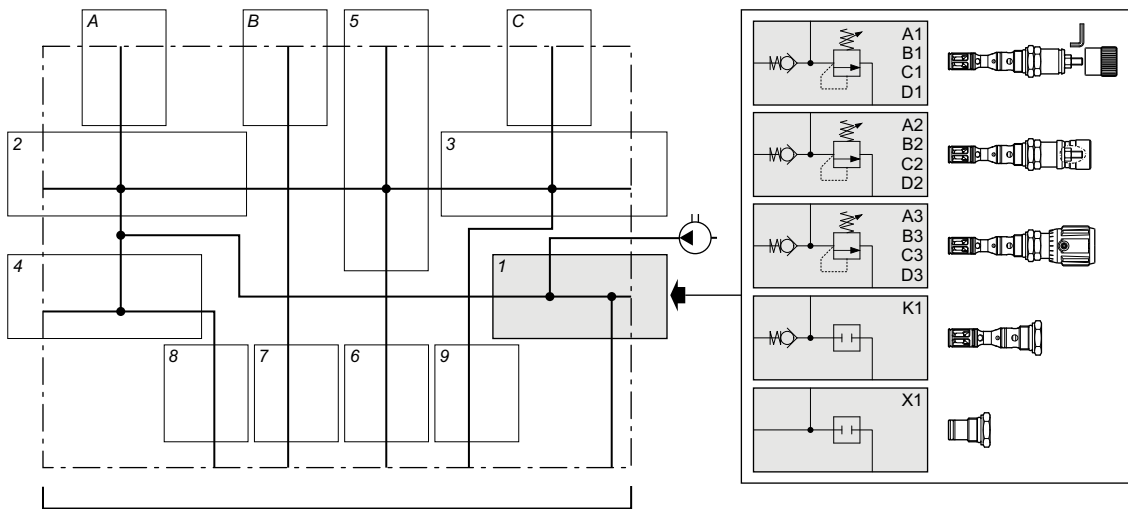
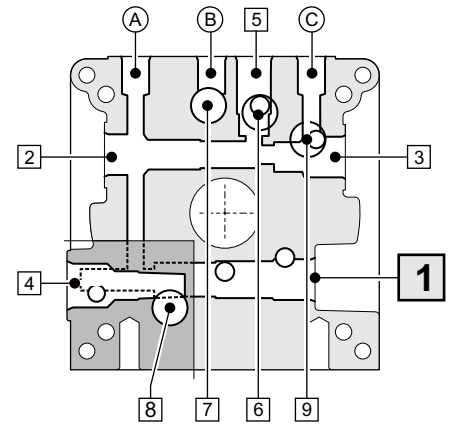
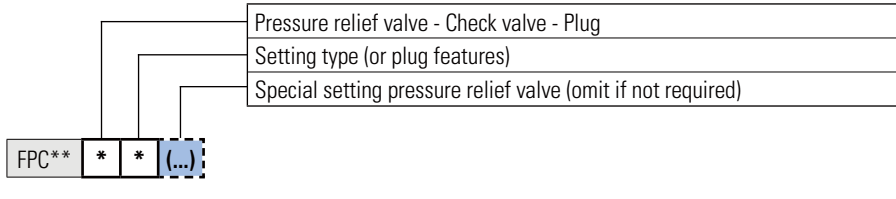

I
FPC

* * (...) Pressure relief valve with check valve

*	*	Pressure (bar)	STD setting (bar)	(...) Special setting (bar)	Setting type	Code	Symbol	Drawing
D	1	15 ÷ 50	30	15 ÷ 50 (5 to 5)	Detachable closing	CMPR04S00002		
	2				Non removable closing (1)	CMPR04P00002		
	3				Plastic knob	CMPR04M00002		
E	1	35 ÷ 110	50	35 ÷ 110 (5 to 5)	Detachable closing	CMPR04S01002		
	2				Non removable closing (1)	CMPR04P01002		
	3				Plastic knob	CMPR04M01002		
F	1	75 ÷ 220	150	75 ÷ 220 (5 to 5)	Detachable closing	CMPR04S02002		
	2				Non removable closing (1)	CMPR04P02002		
	3				Plastic knob	CMPR04M02002		
G	1	160 ÷ 290	180	160 ÷ 290 (10 to 10)	Detachable closing	CMPR04S03002		
	2				Non removable closing (1)	CMPR04P03002		
	3				Plastic knob	CMPR04M03002		

1 = Supplied assembled. Unassembled, see accessories page 89

* * Check valve and plug

*	*	Description	Code	Symbol	Drawing
K	1	Check valve - Opening pressure 0.5 bar	CR10400001		
X	1	Plug	R78150100		

Sect. II - FPC Cavity 2

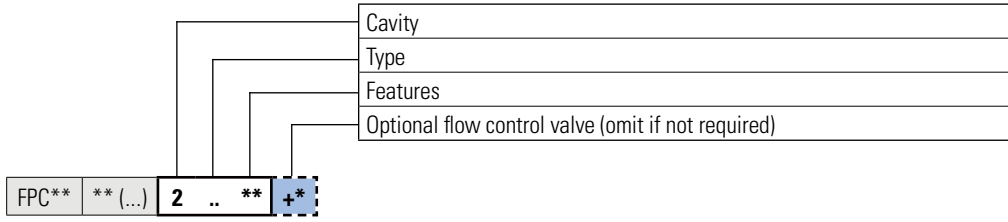

II
FPC

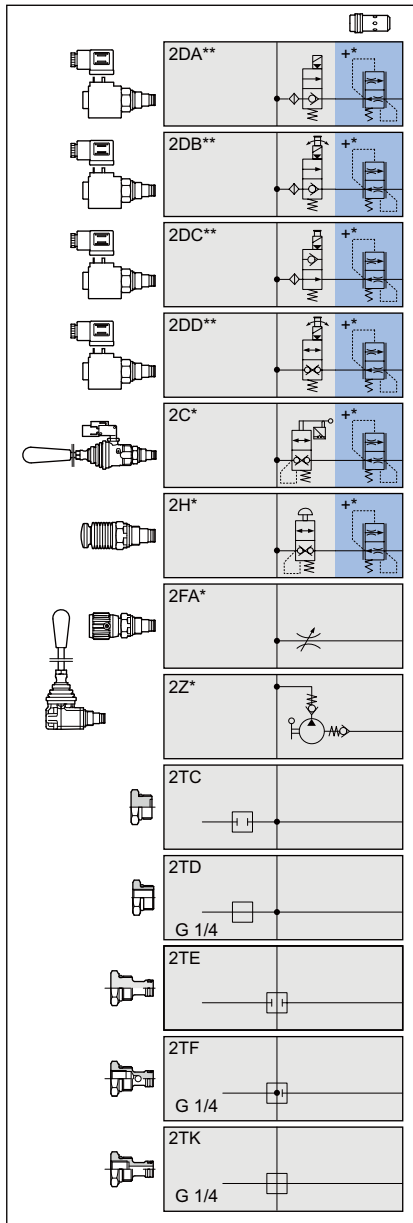

Flow control valves

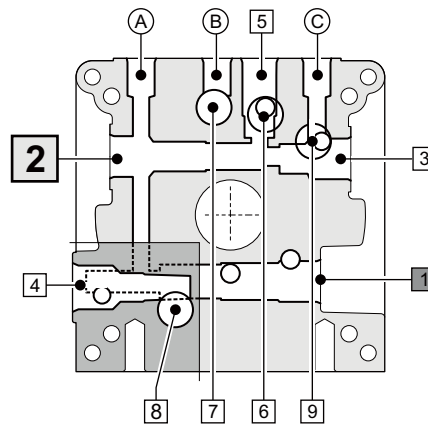
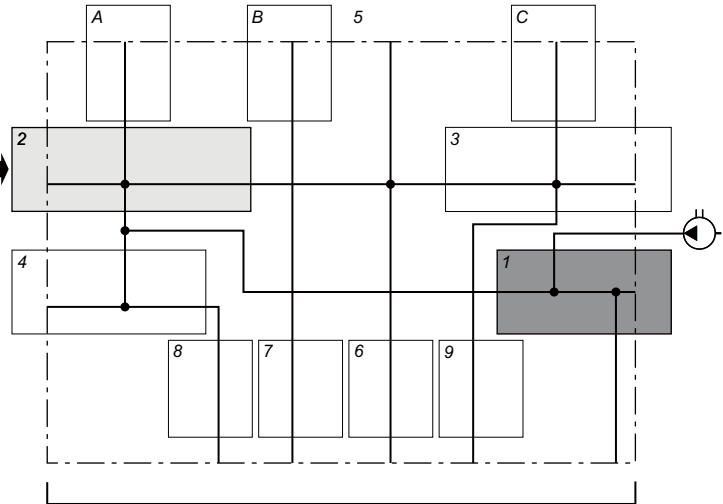

Sect. II - FPC Cavity 2



2 DA ** ⁺* *Piloted solenoid valves normally closed, without emergency (1)*

**	Description	Code (valve + connector)	Symbol	Drawing
AA	Voltage 12 Vdc	CRP0418NCASL003 + V86050002		
AB	Voltage 24 Vdc	CRP0418NCASM003 + V86050002		
AC	Voltage 24 Vac 50 Hz	CRP0418NCASA003 + V86050002		
AD	Voltage 115 Vac 50 Hz	CRP0418NCASJ003 + V86050002		
AE	Voltage 230 Vac 50 Hz	CRP0418NCASI003 + V86050002		

2 DB ** ⁺* *Piloted solenoid valves normally open, with rotary emergency (1)*

**	Description	Code (valve + connector)	Symbol	Drawing
AA	Voltage 12 Vdc	CRP0418NCAEL003 + V86050002		
AB	Voltage 24 Vdc	CRP0418NCAEM003 + V86050002		
AC	Voltage 24 Vac 50 Hz	CRP0418NCAEA003 + V86050002		
AD	Voltage 115 Vac 50 Hz	CRP0418NCAEJ003 + V86050002		
AE	Voltage 230 Vac 50 Hz	CRP0418NCAEI003 + V86050002		

2 DC ** ⁺* *Piloted solenoid valves normally open, with button emergency (1)*

**	Description	Code (valve + connector)	Symbol	Drawing
AA	Voltage 12 Vdc	CRP0418NAAEL003 + V86050002		
AB	Voltage 24 Vdc	CRP0418NAAEM003 + V86050002		
AC	Voltage 24 Vac 50/60 Hz (RAC with rectifier)	CRP0418NAAE2003 + V86200002		
AD	Voltage 115 Vac 50 - 120 Vac 60 Hz (RAC with rectifier)	CRP0418NAAEZ003 + V86200002		
AE	Voltage 230 Vac 50 - 240 Vac 60 Hz (RAC with rectifier)	CRP0418NAAEX003 + V86200002		
AF	Voltage 48 Vdc	CRP0418NAAEN003 + V86050002		

2 DD ** ⁺* *Direct operated solenoid valve normally closed, with button emergency (1)*

**	Description	Code (valve + connector)	Symbol	Drawing
AA	Voltage 12 Vdc	CRD0418NCAEL002 + V86050002		
AB	Voltage 24 Vdc	CRD0418NCAEM002 + V86050002		

2 C * ⁺* *Lever operated valve*

*	Description	Code	Symbol	Drawing
A	Without microswitch	CMF04L001		
B	With microswitch	CMF04M001		

1 = Valves supplied with connector. Without connector see accessories page 89



2 H * +* *Button operated valves*

**	Description	Code	Symbol	Drawing
A	Push-button control	CPE04P000.1		

2 .. ** +* *Flow control valves (1)*

*	Flow	Code	Symbol	Drawing
+B	1.4 l/min	VSC040101		
+C	2.3 l/min	VSC040201		
+E	2.8 l/min	VSC040301		
+G	4.3 l/min	VSC040401		
+J	5.2 l/min	VSC040601		
+L	6.5 l/min	VSC040801		
+N	8.0 l/min	VSC041101		
+Q	11.1 l/min	VSC041601		

(1) The flow control valves can be installed with solenoid valves, with manual controls and with push-button valves.

2 FA * *Bidirectional flow control valves not compensated*

*	Description	Code	Symbol	Drawing
A	Screw adjustment	CSB04C0000		
B	Plastic knob adjustment	CSB04V0000		

2 Z * *Hand pumps*

*	Description	Code	Symbol	Drawing
A	Cilindrata 1 cc	CPM0410001		
B	Cilindrata 2 cc	CPM0420001		

2 T * *Plugs and fittings*

*	Description	Code	Symbol	Drawing
C	Plug 3/4 16 UNF	R78150099		
D	Fitting 3/4 16 UNF - G1/4	20001700		
E	Long plug 3/4 16 UNF	20003800		
F	Fitting 3/4 16 UNF - G1/4	20009400		
K	Fitting 3/4 16 UNF DIN - G1/4	20018000		

Sect. II - FPC Cavity 3

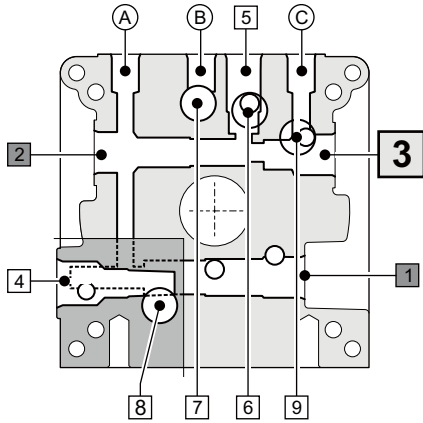
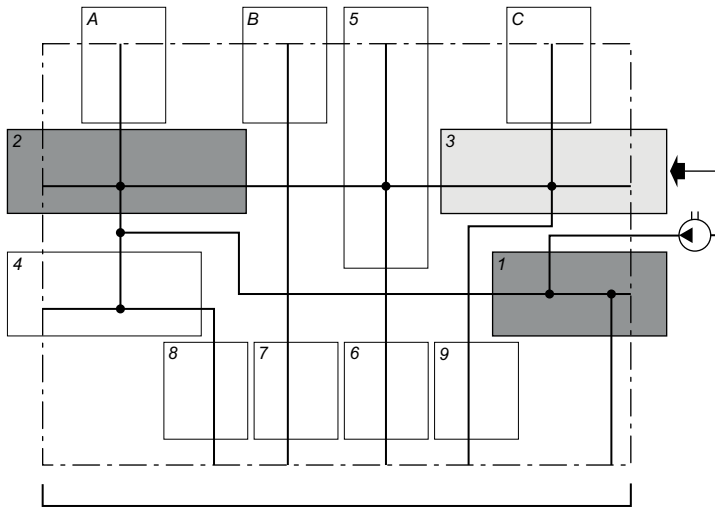
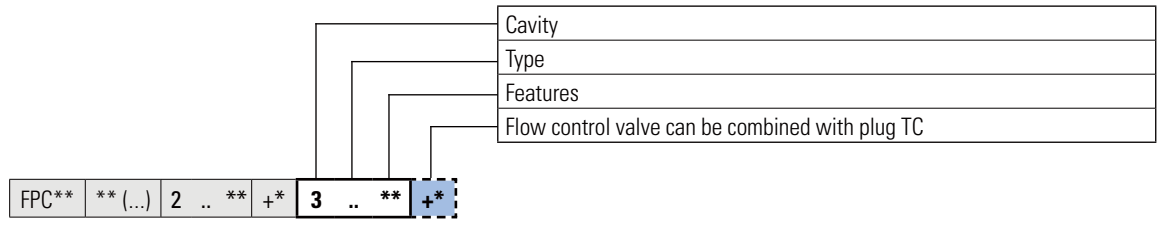

3DD*		
3H*		
3FA*		
3FB*		
3A**		
3B*		
+* 3TC		
3TD		
3TE		
3TF		
3TK		

Flow control valves

3 DD ** *Piloted solenoid valves normally closed, with emergency* ⁽¹⁾

**	Description	Code (valve + connector)	Symbol	Drawing
AA	Voltage 12 Vdc	CRD0418NCAEL002 + V86050002		
AB	Voltage 24 Vdc	CRD0418NCAEM002 + V86050002		

3 H * *Button operated valves*

*	Descrizione	Codice (elettrovalvola + connettore)	Simbolo	Disegno
A	Push-button control	CPE04P000.1		

3 FA * *Bidirectional flow control valves not compensated*

*	Description	Code (valve + connector)	Symbol	Drawing
A	Screw adjustment	CSC04C0000		
B	Plastic knob adjustment	CSC04V0000		

3 FB * *Unidirectional flow control valves compensated*

*	Description	Code (valve + connector)	Symbol	Drawing
A	Screw adjustment	CSC04C0000		
B	Plastic knob adjustment	CSC04V0000		

3 A ** *Pressure relief valves*

**	Description	Regolazione (bar)	Code	Symbol	Drawing	
AD	Short screw adjustment	Min 15 - Max 50	CMP04AS0002			
AE		Min 35 - Max 110	CMP04AS1002			
AF		Min 75 - Max 220	CMP04AS2002			
AG		Min 160 - Max 290	CMP04AS3002			
BD	Screw adjustment	Min 15 - Max 50	CMP04AC0002			
BE		Min 35 - Max 110	CMP04AC1002			
BF		Min 75 - Max 220	CMP04AC2002			
BG		Min 160 - Max 290	CMP04AC3002			
CD	Plastic knob adjustment	Min 15 - Max 50	CMP04AM0002			
CE		Min 35 - Max 110	CMP04AM1002			
CF		Min 75 - Max 220	CMP04AM2002			
CG		Min 160 - Max 290	CMP04AM3002			
DD	Short screw + sealed cap	Min 15 - Max 50	CMP04AP0002			
DE		Min 35 - Max 110	CMP04AP1002			
DF		Min 75 - Max 220	CMP04AP2002			
DG		Min 160 - Max 290	CMP04AP3002			

¹ = Valves supplied with connector. Without connector see accessories page 89

3 B * One-way check valves

*	Description	Code (valve + connector)	Symbol	Drawing
A	0.7 bar (Standard)	CRU0400002		
B	4.5 bar	CRU0404002		
C	10 bar	CRU0410002		

3 T * +* Plugs and fittings

*	Description	Code	Symbol	Drawing
C	Plug 3/4 16 UNF ⁽¹⁾	R78150099		
D	Fitting 3/4 16 UNF - G1/4	20001700		
E	Long plug 3/4 16 UNF	20003800		
F	Fitting 3/4 16 UNF - G1/4	20009400		
K	Fitting 3/4 16 UNF - DIN G1/4	20018000		

3 T C +* Flow control valves ⁽¹⁾

*	Flow	Code	Symbol	Drawing
+B	1.4 l/min	VSC040101		
+C	2.3 l/min	VSC040201		
+E	2.8 l/min	VSC040301		
+G	4.3 l/min	VSC040401		
+J	5.2 l/min	VSC040601		
+L	6.5 l/min	VSC040801		
+N	8.0 l/min	VSC041101		
+Q	11.1 l/min	VSC041601		

⁽¹⁾ The flow control valves can be installed with the plug TC.

Sect. II - FPC Cavity 4



Cavity
Type
Features

FPC** ** (...) 2 .. ** +* 3 .. ** +* **4** .. **

	4DA**	
	4DB**	
	4DC**	
	4DD**	
	4C*	
	4H*	
	4FA*	
	4Z*	
	4TE	
	4TF	
	4TK	

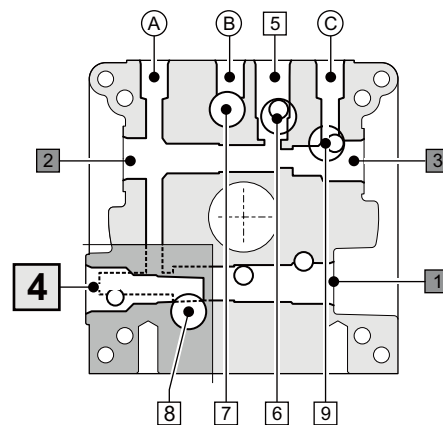
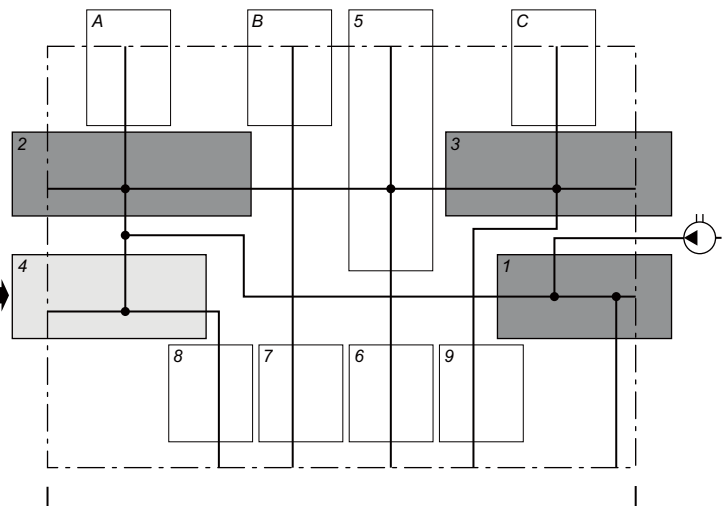

II
FPC

Sect. II - FPC Cavity 4



4 DA ** *Piloted solenoid valves normally closed, without emergency (1)*

**	Description	Code (valve + connector)	Symbol	Drawing
AA	Voltage 12 Vdc	CRP0418NCASL003 + V86050002		
AB	Voltage 24 Vdc	CRP0418NCASM003 + V86050002		
AC	Voltage 24 Vac 50 Hz	CRP0418NCASA003 + V86050002		
AD	Voltage 115 Vac 50 Hz	CRP0418NCASJ003 + V86050002		
AE	Voltage 230 Vac 50 Hz	CRP0418NCASI003 + V86050002		

4 DB ** *Piloted solenoid valves normally open, with rotary emergency (1)*

**	Description	Code (valve + connector)	Symbol	Drawing
AA	Voltage 12 Vdc	CRP0418NCAEL003 + V86050002		
AB	Voltage 24 Vdc	CRP0418NCAEM003 + V86050002		
AC	Voltage 24 Vac 50 Hz	CRP0418NCAEA003 + V86050002		
AD	Voltage 115 Vac 50 Hz	CRP0418NCAEJ003 + V86050002		
AE	Voltage 230 Vac 50 Hz	CRP0418NCAEI003 + V86050002		

4 DC ** *Piloted solenoid valves normally open, with button emergency (1)*

**	Description	Code (valve + connector)	Symbol	Drawing
AA	Voltage 12 Vdc	CRP0418NAAEL003 + V86050002		
AB	Voltage 24 Vdc	CRP0418NAAEM003 + V86050002		
AC	Voltage 24 Vac 50/60 Hz (RAC with rectifier)	CRP0418NAAE2003 + V86200002		
AD	Voltage 115 Vac 50 - 120 Vac 60 Hz (RAC with rectifier)	CRP0418NAAEZ003 + V86200002		
AE	Voltage 230 Vac 50 - 240 Vac 60 Hz (RAC with rectifier)	CRP0418NAAEX003 + V86200002		
AF	Voltage 48 Vdc	CRP0418NAAEN003 + V86050002		

4 DD ** *Direct operated solenoid valve normally closed, with button emergency (1)*

**	Description	Code (valve + connector)	Symbol	Drawing
AA	Voltage 12 Vdc	CRD0418NCAEL002 + V86050002		
AB	Voltage 24 Vdc	CRD0418NCAEM002 + V86050002		

1 = Valves supplied with connector. Without connector see accessories page 89

4 C * *Lever operated valve*

* Description	Code	Symbol	Drawing
A Without microswitch	CMF04L001		
B With microswitch	CMF04M001		

4 H * *Button operated valves*

** Description	Code	Symbol	Drawing
A Push-button control	CPE04P000.1		

4 FA * *Bidirectional flow control valves not compensated*

* Description	Code	Symbol	Drawing
A Screw adjustment	CSB04C0000		
B Plastic knob adjustment	CSB04V0000		

4 Z * *Hand pumps*

* Description	Code	Symbol	Drawing
A Cilindrata 1 cc	CPM0410001		
B Cilindrata 2 cc	CPM0420001		

4 T * *Plugs and fittings*

* Description	Code	Symbol	Drawing
E Long plug 3/4 16 UNF	20003800		
F Fitting 3/4 16 UNF - G1/4	20009400		
K Fitting 3/4 16 UNF DIN - G1/4	20018000		

- Peripheral
- Plug
- Features
- Flow control valve can be combined with plug TG

FPC** ** (...) 2 .. ** +* 3 .. ** +* 4 .. ** 5 T * **+***

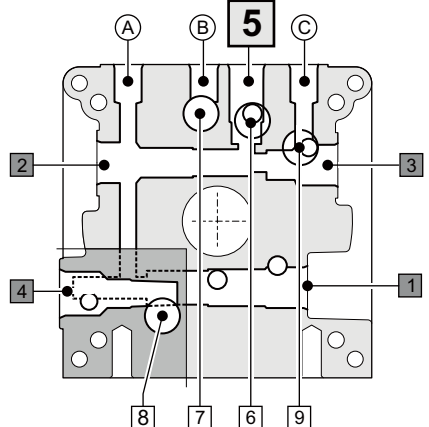
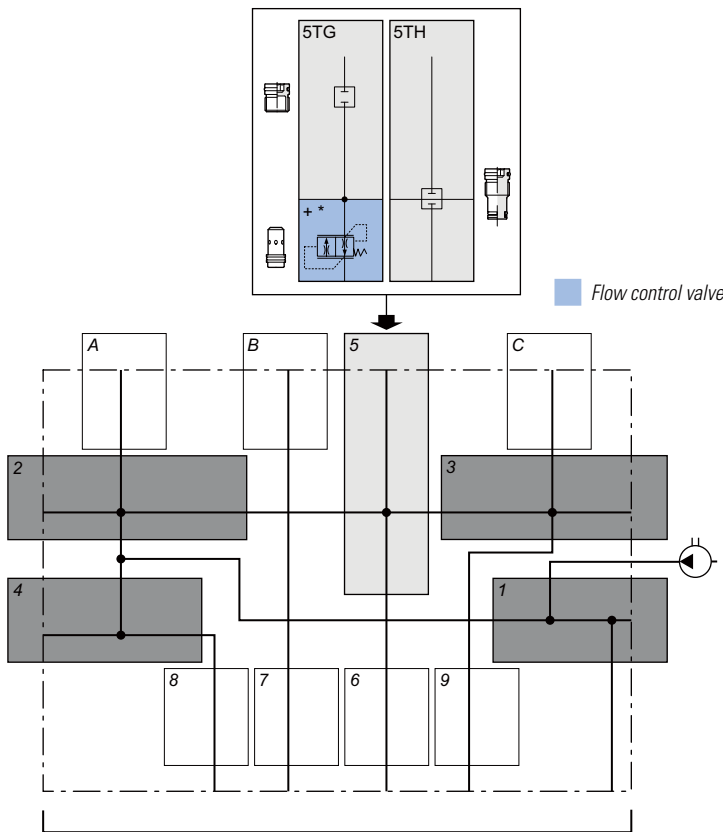

5 T * +* Plugs

*	Description	Code	Symbol	Drawing
G	Plug M16x1.5 ⁽¹⁾	R78150104		
H	Long plug M16x1.5	R78150101		

5 T G +* Flow control valves ⁽¹⁾

*	Flow	Code	Symbol	Drawing
+B	1.4 l/min	VSC040101		
+C	2.3 l/min	VSC040201		
+E	2.8 l/min	VSC040301		
+G	4.3 l/min	VSC040401		
+J	5.2 l/min	VSC040601		
+L	6.5 l/min	VSC040801		
+N	8.0 l/min	VSC041101		
+Q	11.1 l/min	VSC041601		

⁽¹⁾ The flow control valves can be installed with the plug TG.

Sect. II - FPC Cavity 6-7-8-9

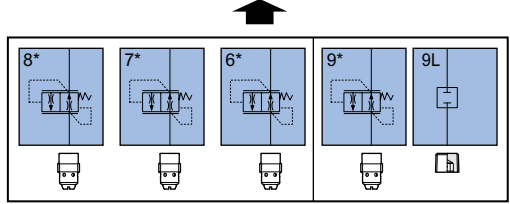
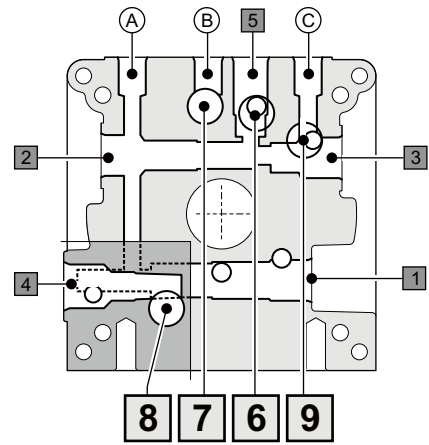
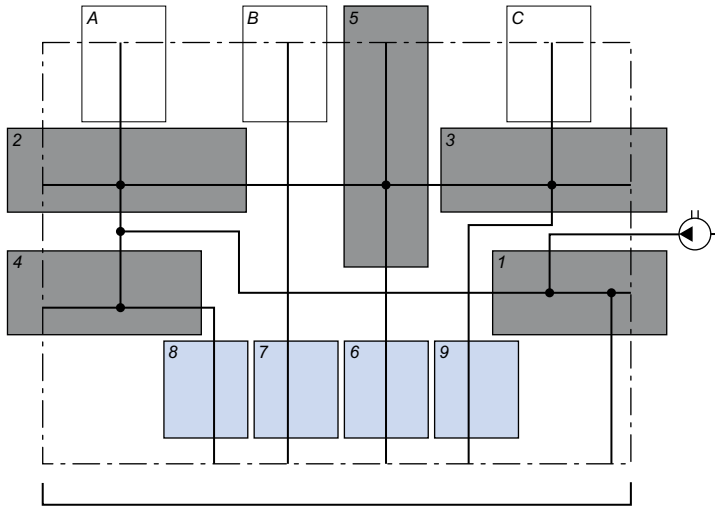
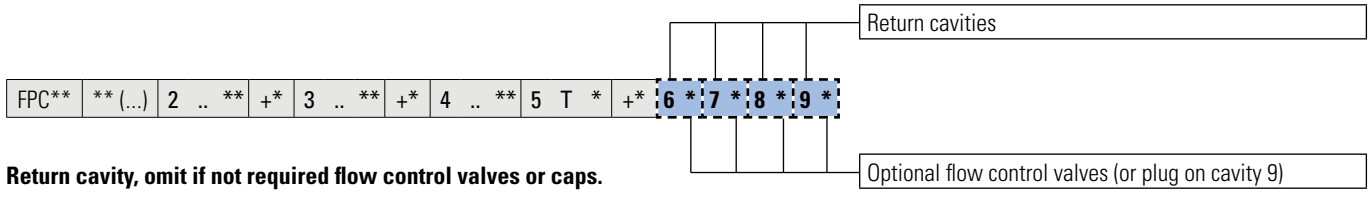

Optional flow control valves (or plug on cavity 9).

6 * Flow control valves for return cavities 6-7-8-9*

* A	Nominal flow at 120 bar	Code	Symbol	Drawing
A	0.7 l/min	VSC06100002		
B	1.1 l/min	VSC06120002		
C	2.1 l/min	VSC06130002		
E	3.2 l/min	VSC06150002		
G	4.7 l/min	VSC06190002		
K	6.3 l/min	VSC06220002		
N	7.5 l/min	VSC06240002		
Q	10.0 l/min	VSC06280002		
U	13.2 l/min	VSC06330002		
V	15.7 l/min	VSC06350002		

9T * Plugs for return cavity "9"

* M	Description	Code	Symbol	Drawing
M	Conical plug G3/8	Q26620350		

Combinations plugs on ports
End section II

FPC** ** (...) 2 .. ** +* 3 .. ** +* 4 .. ** 5 T * +* 6 * 7 * 8 * 9 * **-**** -

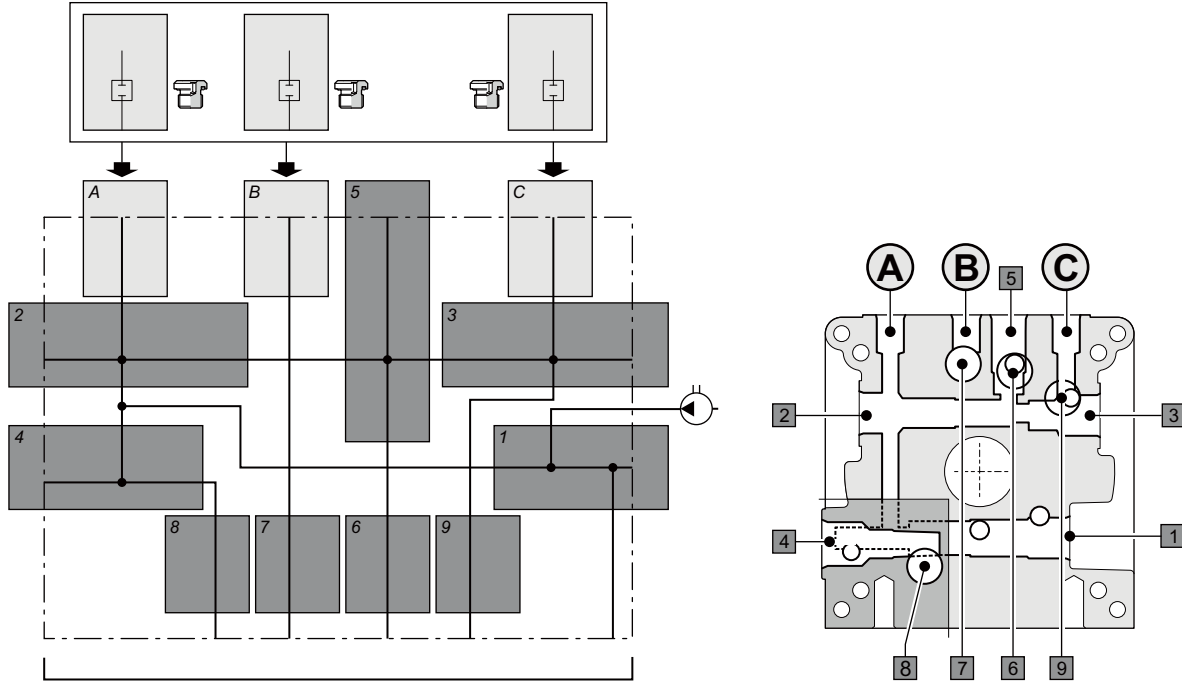

II
FPC

-** Combinations plugs on ports A-B-C

-**	A	B	C
-00	↑	↑	⊗
-01	↑	↑	↑
-02	⊗	↑	↑
-03	↑	⊗	↑
-05	↑	⊗	⊗
-06	⊗	⊗	↑
-07	⊗	↑	⊗
-08	⊗	⊗	⊗

Symbols description

Type	Description	Thread	Code	Symbol	Drawing
⊗	Port closed with plug	G 1/4"	20024000		
		G 3/8"	Q26630006 (plug with OR)		
↑	Port open		—	—	—

Combination -00 to use with the standard blocks (page 85)

Sect. I - FPL Cavity 1

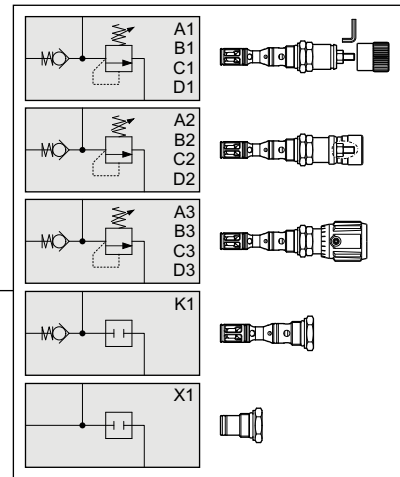
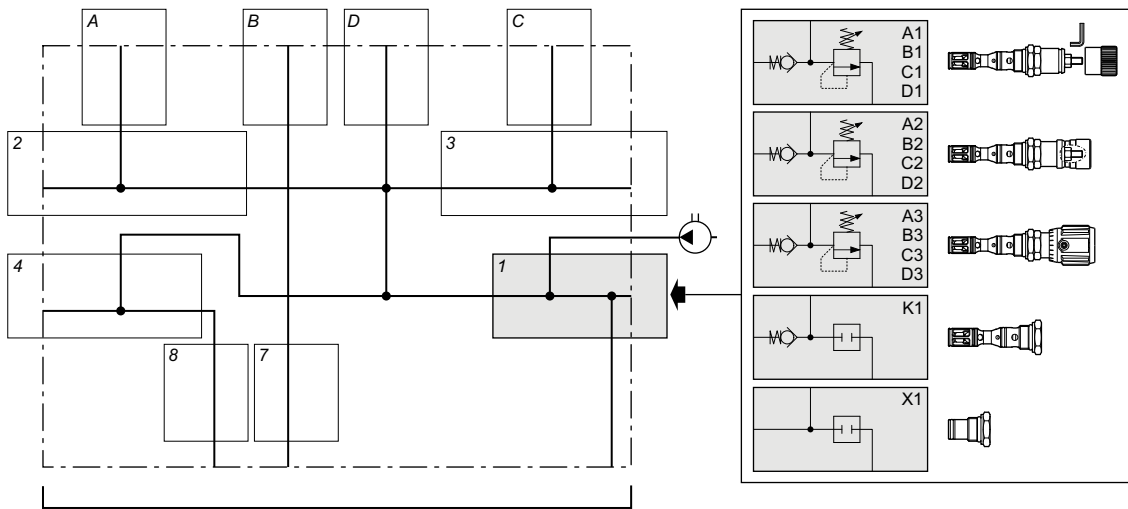
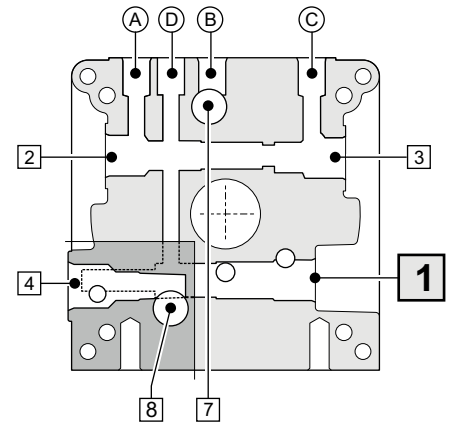
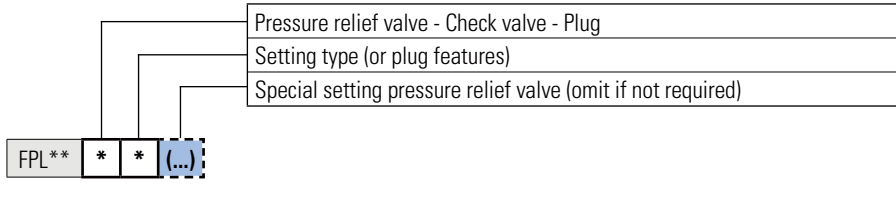

* * (...) Pressure relief valve with check valve

*	*	Pressure (bar)	STD setting (bar)	(...) Special setting (bar)	Setting type	Code	Symbol	Drawing
D	1	15 ÷ 50	30	15 ÷ 50 (5 to 5)	Detachable closing	CMPR04S00002		
	2				Non removable closing (1)	CMPR04P00002		
	3				Plastic knob	CMPR04M00002		
E	1	35 ÷ 110	50	35 ÷ 110 (5 to 5)	Detachable closing	CMPR04S01002		
	2				Non removable closing (1)	CMPR04P01002		
	3				Plastic knob	CMPR04M01002		
F	1	75 ÷ 220	150	75 ÷ 220 (5 to 5)	Detachable closing	CMPR04S02002		
	2				Non removable closing (1)	CMPR04P02002		
	3				Plastic knob	CMPR04M02002		
G	1	160 ÷ 290	180	160 ÷ 290 (10 to 10)	Detachable closing	CMPR04S03002		
	2				Non removable closing (1)	CMPR04P03002		
	3				Plastic knob	CMPR04M03002		

1 = Supplied assembled. Unassembled, see accessories page 89

* * Check valve and plug

*	*	Description	Code	Symbol	Drawing
K	1	Check valve - Opening pressure 0.5 bar	CR10400001		
X	1	Plug	R78150100		

Sect. II - FPL Cavity 2

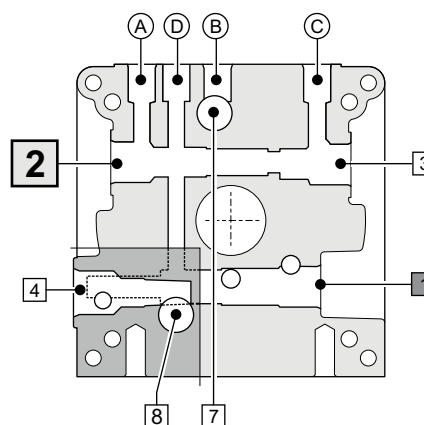
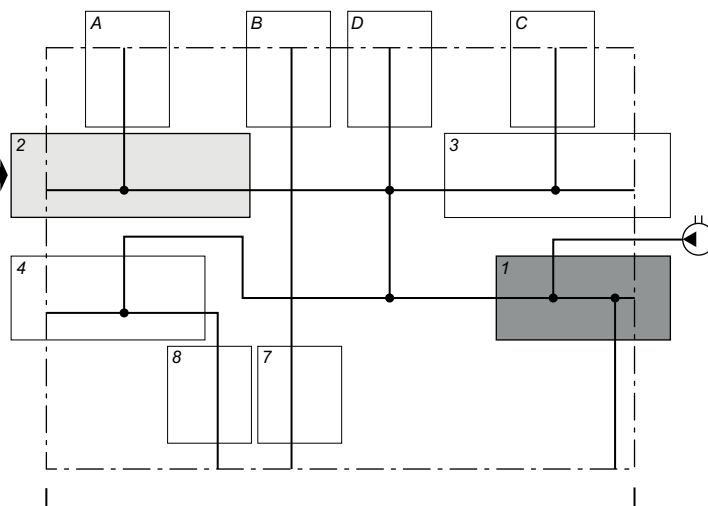
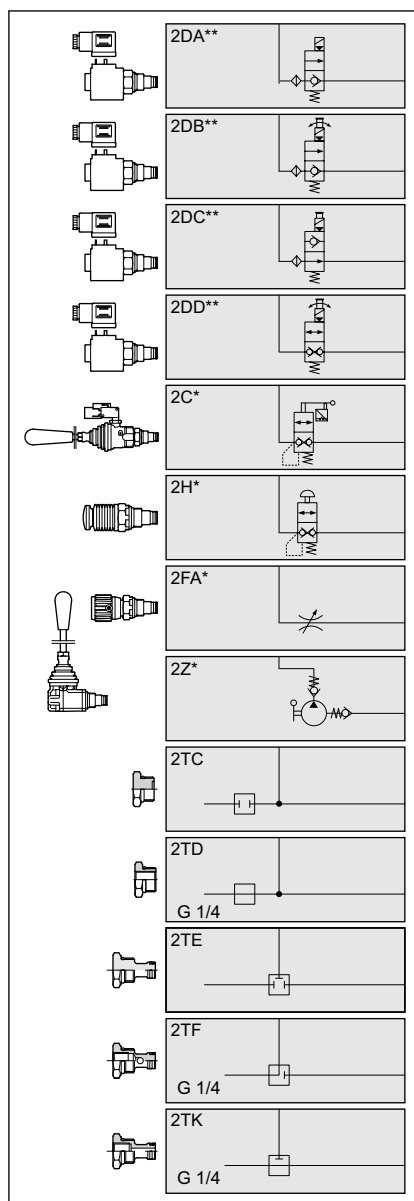
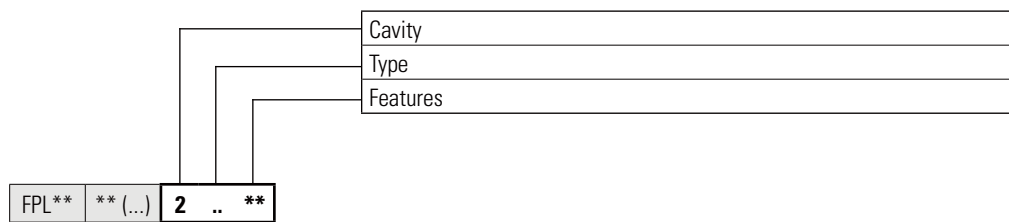

2 DA ** *Piloted solenoid valves normally closed, without emergency (1)*

**	Description	Code (valve + connector)	Symbol	Drawing
AA	Voltage 12 Vdc	CRP0418NCASL003 + V86050002		
AB	Voltage 24 Vdc	CRP0418NCASM003 + V86050002		
AC	Voltage 24 Vac 50 Hz	CRP0418NCASA003 + V86050002		
AD	Voltage 115 Vac 50 Hz	CRP0418NCASJ003 + V86050002		
AE	Voltage 230 Vac 50 Hz	CRP0418NCASI003 + V86050002		

2 DB ** *Piloted solenoid valves normally open, with rotary emergency (1)*

**	Description	Code (valve + connector)	Symbol	Drawing
AA	Voltage 12 Vdc	CRP0418NCAEL003 + V86050002		
AB	Voltage 24 Vdc	CRP0418NCAEM003 + V86050002		
AC	Voltage 24 Vac 50 Hz	CRP0418NCAEA003 + V86050002		
AD	Voltage 115 Vac 50 Hz	CRP0418NCAEJ003 + V86050002		
AE	Voltage 230 Vac 50 Hz	CRP0418NCAEI003 + V86050002		

2 DC ** *Piloted solenoid valves normally open, with button emergency (1)*

**	Description	Code (valve + connector)	Symbol	Drawing
AA	Voltage 12 Vdc	CRP0418NAAEL003 + V86050002		
AB	Voltage 24 Vdc	CRP0418NAAEM003 + V86050002		
AC	Voltage 24 Vac 50/60 Hz (RAC with rectifier)	CRP0418NAAE2003 + V86200002		
AD	Voltage 115 Vac 50 - 120 Vac 60 Hz (RAC with rectifier)	CRP0418NAAEZ003 + V86200002		
AE	Voltage 230 Vac 50 - 240 Vac 60 Hz (RAC with rectifier)	CRP0418NAAEX003 + V86200002		
AF	Voltage 48 Vdc	CRP0418NAAEN003 + V86050002		

2 DD ** *Direct operated solenoid valve normally closed, with button emergency (1)*

**	Description	Code (valve + connector)	Symbol	Drawing
AA	Voltage 12 Vdc	CRD0418NCAEL002 + V86050002		
AB	Voltage 24 Vdc	CRD0418NCAEM002 + V86050002		

2 C * *Lever operated valve*

*	Description	Code	Symbol	Drawing
A	Without microswitch	CMF04L001		
B	With microswitch	CMF04M001		

1 = Valves supplied with connector. Without connector see accessories page 89

Sect. II - FPL Cavity 2



2 H * *Button operated valves*

**	Description	Code	Symbol	Drawing
A	Push-button control	CPE04P000.1		

2 FA * *Bidirectional flow control valves not compensated*

*	Description	Code	Symbol	Drawing
A	Screw adjustment	CSB04C0000		
B	Plastic knob adjustment	CSB04V0000		

2 Z * *Hand pumps*

*	Description	Code	Symbol	Drawing
A	Cilindrata 1 cc	CPM0410001		
B	Cilindrata 2 cc	CPM0420001		

2 T * *Plugs and fittings*

*	Description	Code	Symbol	Drawing
C	Plug 3/4 16 UNF	R78150099		
D	Fitting 3/4 16 UNF - G1/4	20001700		
E	Long plug 3/4 16 UNF	20003800		
F	Fitting 3/4 16 UNF - G1/4	20009400		
K	Fitting 3/4 16 UNF DIN - G1/4	20018000		

II
FPL

Sect. II - FPL Cavity 3

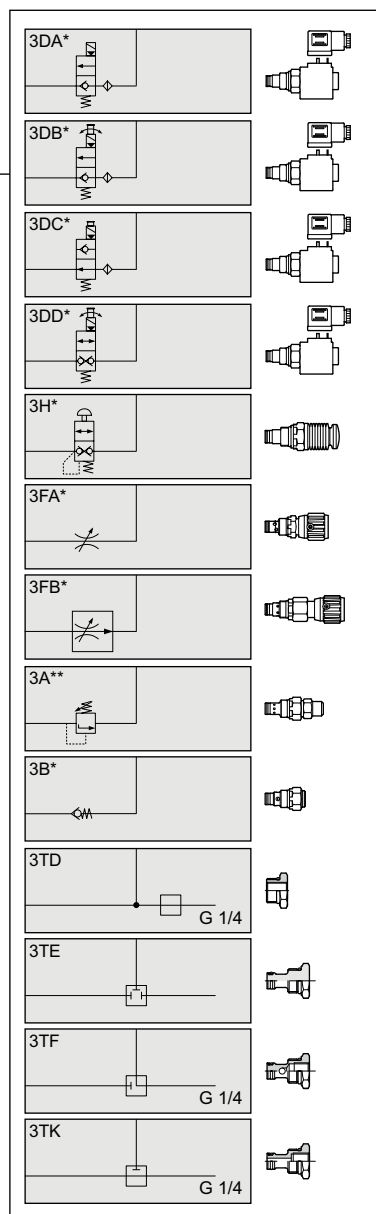
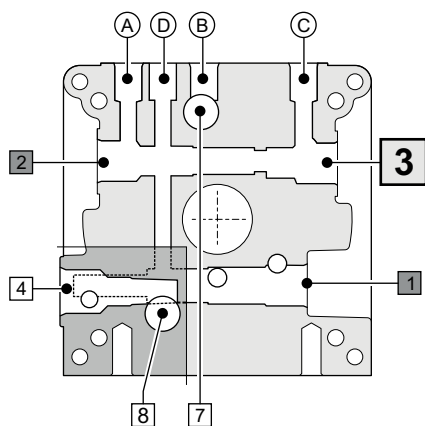
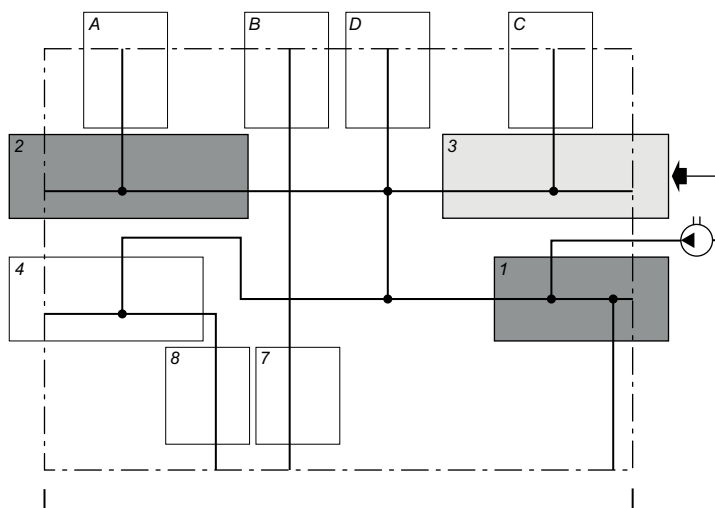
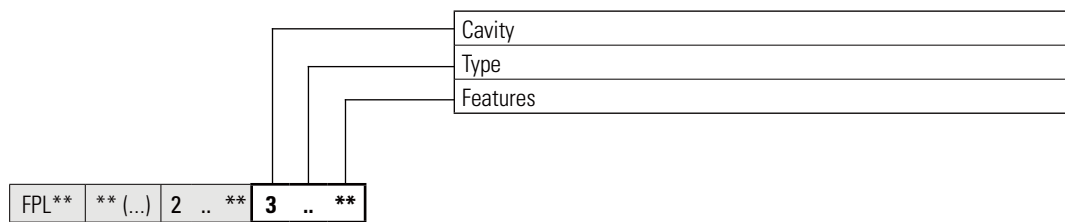

II
FPL

Sect. II - FPL Cavity 3



3 DA ** *Piloted solenoid valves normally closed, without emergency (1)*

**	Description	Code (valve + connector)	Symbol	Drawing
AA	Voltage 12 Vdc	CRP0418NCASL003 + V86050002		
AB	Voltage 24 Vdc	CRP0418NCASM003 + V86050002		
AC	Voltage 24 Vac 50 Hz	CRP0418NCASA003 + V86050002		
AD	Voltage 115 Vac 50 Hz	CRP0418NCASJ003 + V86050002		
AE	Voltage 230 Vac 50 Hz	CRP0418NCASI003 + V86050002		

3 DB ** *Piloted solenoid valves normally open, with rotary emergency (1)*

**	Description	Code (valve + connector)	Symbol	Drawing
AA	Voltage 12 Vdc	CRP0418NCAEL003 + V86050002		
AB	Voltage 24 Vdc	CRP0418NCAEM003 + V86050002		
AC	Voltage 24 Vac 50 Hz	CRP0418NCAEA003 + V86050002		
AD	Voltage 115 Vac 50 Hz	CRP0418NCAEJ003 + V86050002		
AE	Voltage 230 Vac 50 Hz	CRP0418NCAEI003 + V86050002		

3 DC ** *Piloted solenoid valves normally open, with button emergency (1)*

**	Description	Code (valve + connector)	Symbol	Drawing
AA	Voltage 12 Vdc	CRP0418NAAEL003 + V86050002		
AB	Voltage 24 Vdc	CRP0418NAAEM003 + V86050002		
AC	Voltage 24 Vac 50/60 Hz (RAC with rectifier)	CRP0418NAAE2003 + V86200002		
AD	Voltage 115 Vac 50 - 120 Vac 60 Hz (RAC with rectifier)	CRP0418NAAEZ003 + V86200002		
AE	Voltage 230 Vac 50 - 240 Vac 60 Hz (RAC with rectifier)	CRP0418NAAEX003 + V86200002		
AF	Voltage 48 Vdc	CRP0418NAAEN003 + V86050002		

3 DD ** *Direct operated solenoid valve normally closed, with button emergency (1)*

**	Description	Code (valve + connector)	Symbol	Drawing
AA	Voltage 12 Vdc	CRD0418NCAEL002 + V86050002		
AB	Voltage 24 Vdc	CRD0418NCAEM002 + V86050002		

3 H * *Button operated valves*

*	Descrizione	Codice (elettrovalvola + connettore)	Simbolo	Disegno
A	Push-button control	CPE04P000.1		

3 FA * *Bidirectional flow control valves not compensated*

*	Description	Code (valve + connector)	Symbol	Drawing
A	Screw adjustment	CSB04C0000		
B	Plastic knob adjustment	CSB04V0000		

1 = Valves supplied with connector. Without connector see accessories page 89

3 FB * Unidirectional flow control valves compensated

*	Description	Code (valve + connector)	Symbol	Drawing
A	Screw adjustment	CSC04C0000		
B	Plastic knob adjustment	CSC04V0000		

3 A ** Pressure relief valves

**	Description	Regolazione (bar)	Code	Symbol	Drawing
AD	Short screw adjustment	Min 15 - Max 50	CMPAS0002		
AE		Min 35 - Max 110	CMPAS1002		
AF		Min 75 - Max 220	CMPAS2002		
AG		Min 160 - Max 290	CMPAS3002		
BD	Screw adjustment	Min 15 - Max 50	CMPAC0002		
BE		Min 35 - Max 110	CMPAC1002		
BF		Min 75 - Max 220	CMPAC2002		
BG		Min 160 - Max 290	CMPAC3002		
CD	Plastic knob adjustment	Min 15 - Max 50	CMPAM0002		
CE		Min 35 - Max 110	CMPAM1002		
CF		Min 75 - Max 220	CMPAM2002		
CG		Min 160 - Max 290	CMPAM3002		
DD	Short screw + sealed cap	Min 15 - Max 50	CMPAP0002		
DE		Min 35 - Max 110	CMPAP1002		
DF		Min 75 - Max 220	CMPAP2002		
DG		Min 160 - Max 290	CMPAP3002		

3 B * One-way check valves

*	Description	Code (valve + connector)	Symbol	Drawing
A	0.7 bar (Standard)	CRU0400002		
B	4.5 bar	CRU0404002		
C	10 bar	CRU0410002		

3 T * Plugs and fittings

*	Description	Code	Symbol	Drawing
D	Fitting 3/4 16 UNF - G1/4	20001700		
E	Long plug 3/4 16 UNF	20003800		
F	Fitting 3/4 16 UNF - G1/4	20009400		
K	Fitting 3/4 16 UNF - DIN G1/4	20018000		

Sect. II - FPL Cavity 4

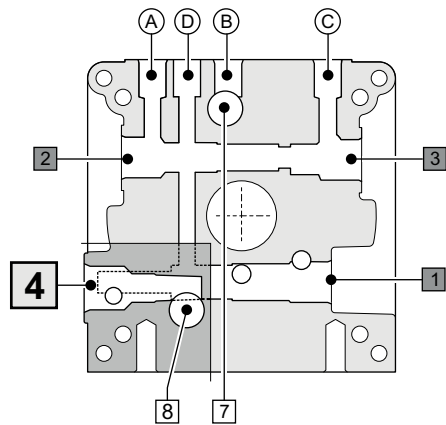
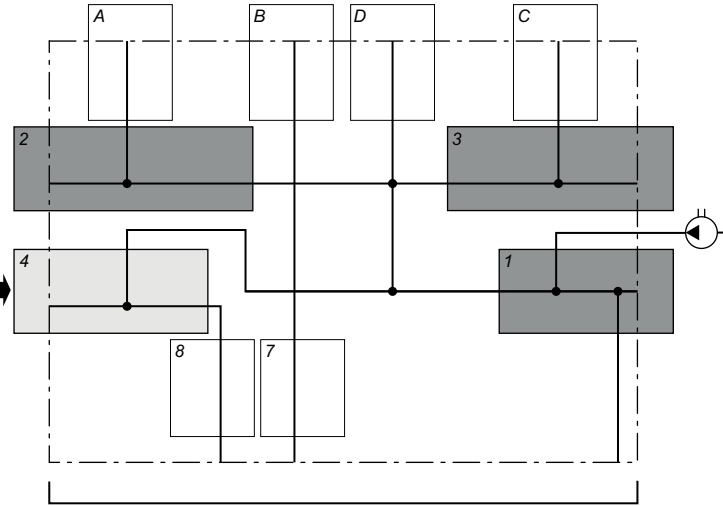
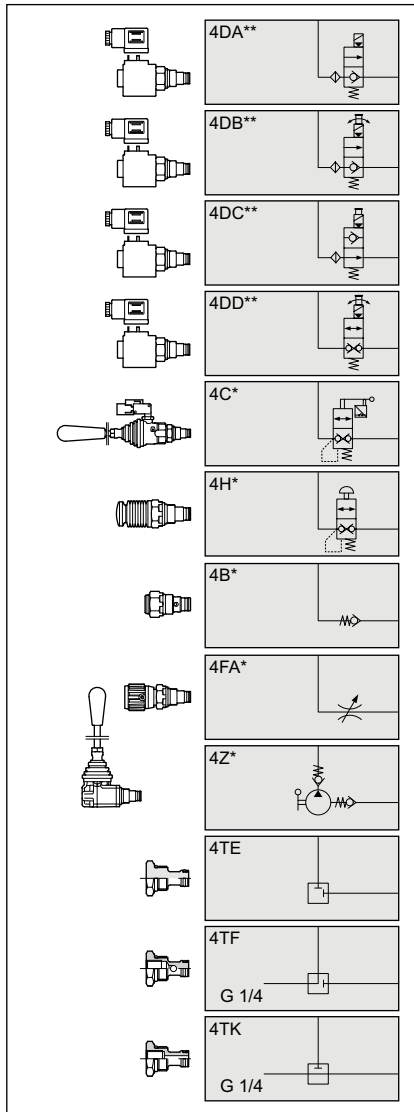
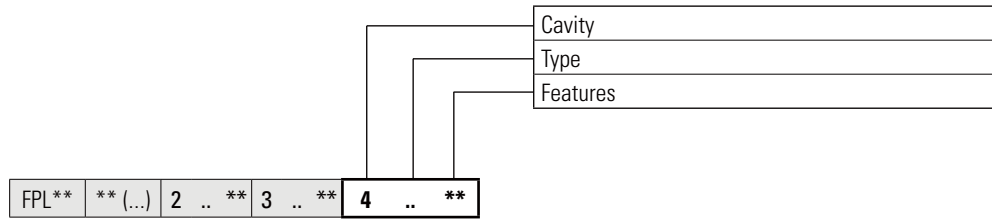

II
FPL

Sect. II - FPL Cavity 4



4 DA ** *Piloted solenoid valves normally closed, without emergency (1)*

**	Description	Code (valve + connector)	Symbol	Drawing
AA	Voltage 12 Vdc	CRP0418NCASL003 + V86050002		
AB	Voltage 24 Vdc	CRP0418NCASM003 + V86050002		
AC	Voltage 24 Vac 50 Hz	CRP0418NCASA003 + V86050002		
AD	Voltage 115 Vac 50 Hz	CRP0418NCASJ003 + V86050002		
AE	Voltage 230 Vac 50 Hz	CRP0418NCASI003 + V86050002		

4 DB ** *Piloted solenoid valves normally open, with rotary emergency (1)*

**	Description	Code (valve + connector)	Symbol	Drawing
AA	Voltage 12 Vdc	CRP0418NCAEL003 + V86050002		
AB	Voltage 24 Vdc	CRP0418NCAEM003 + V86050002		
AC	Voltage 24 Vac 50 Hz	CRP0418NCAEA003 + V86050002		
AD	Voltage 115 Vac 50 Hz	CRP0418NCAEJ003 + V86050002		
AE	Voltage 230 Vac 50 Hz	CRP0418NCAEI003 + V86050002		

4 DC ** *Piloted solenoid valves normally open, with button emergency (1)*

**	Description	Code (valve + connector)	Symbol	Drawing
AA	Voltage 12 Vdc	CRP0418NAAEL003 + V86050002		
AB	Voltage 24 Vdc	CRP0418NAAEM003 + V86050002		
AC	Voltage 24 Vac 50/60 Hz (RAC with rectifier)	CRP0418NAAE2003 + V86200002		
AD	Voltage 115 Vac 50 - 120 Vac 60 Hz (RAC with rectifier)	CRP0418NAAEZ003 + V86200002		
AE	Voltage 230 Vac 50 - 240 Vac 60 Hz (RAC with rectifier)	CRP0418NAAEX003 + V86200002		
AF	Voltage 48 Vdc	CRP0418NAAEN003 + V86050002		

4 DD ** *Direct operated solenoid valve normally closed, with button emergency (1)*

**	Description	Code (valve + connector)	Symbol	Drawing
AA	Voltage 12 Vdc	CRD0418NCAEL002 + V86050002		
AB	Voltage 24 Vdc	CRD0418NCAEM002 + V86050002		

4 C * *Lever operated valve*

*	Description	Code	Symbol	Drawing
A	Without microswitch	CMF04L001		
B	With microswitch	CMF04M001		

1 = Valves supplied with connector. Without connector see accessories page 89

4 B * *One-way check valves*

*	Description	Code (valve + connector)	Symbol	Drawing
A	0.7 bar (Standard)	CRU0400002		
B	4.5 bar	CRU0404002		
C	10 bar	CRU0410002		

4 H * *Button operated valves*

**	Description	Code	Symbol	Drawing
A	Push-button control	CPE04P000.1		

4 FA * *Bidirectional flow control valves not compensated*

*	Description	Code	Symbol	Drawing
A	Screw adjustment	CSB04C0000		
B	Plastic knob adjustment	CSB04V0000		

4 Z * *Hand pumps*

*	Description	Code	Symbol	Drawing
A	Cilindrata 1 cc	CPM0410001		
B	Cilindrata 2 cc	CPM0420001		

4 T * *Plugs and fittings*

*	Description	Code	Symbol	Drawing
E	Long plug 3/4 16 UNF	20003800		
F	Fitting 3/4 16 UNF - G1/4	20009400		
K	Fitting 3/4 16 UNF DIN - G1/4	20018000		

II
FPL

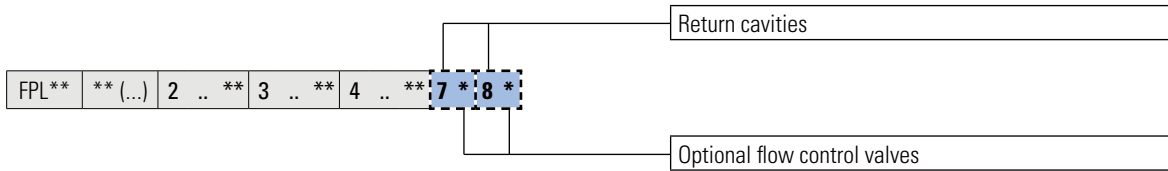

Return cavity, omit if not required flow control valves.

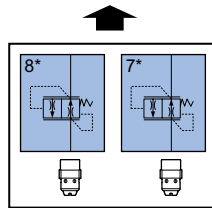
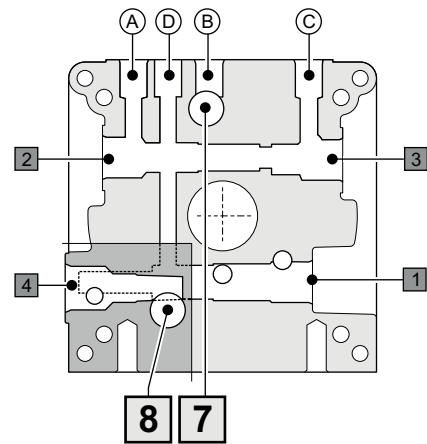
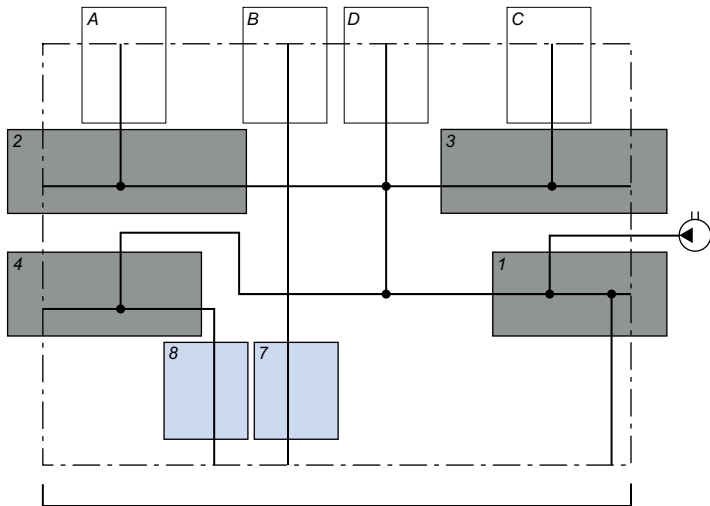

Optional flow control valves.

7 * Flow control valves for return cavities "7-8"

* 8	*	Nominal flow at 120 bar	Code	Symbol	Drawing
	A	0.7 l/min	VSC06100002		
	B	1.1 l/min	VSC06120002		
	C	2.1 l/min	VSC06130002		
	E	3.2 l/min	VSC06150002		
	G	4.7 l/min	VSC06190002		
	K	6.3 l/min	VSC06220002		
	N	7.5 l/min	VSC06240002		
	Q	10.0 l/min	VSC06280002		
	U	13.2 l/min	VSC06330002		
	V	15.7 l/min	VSC06350002		

Sect. II - FTL Ports A-B-C-D



Combinations plugs on ports
End section II

FPL** ** (...) 2 .. ** 3 .. ** 4 .. ** 7 * 8 * **-**** -

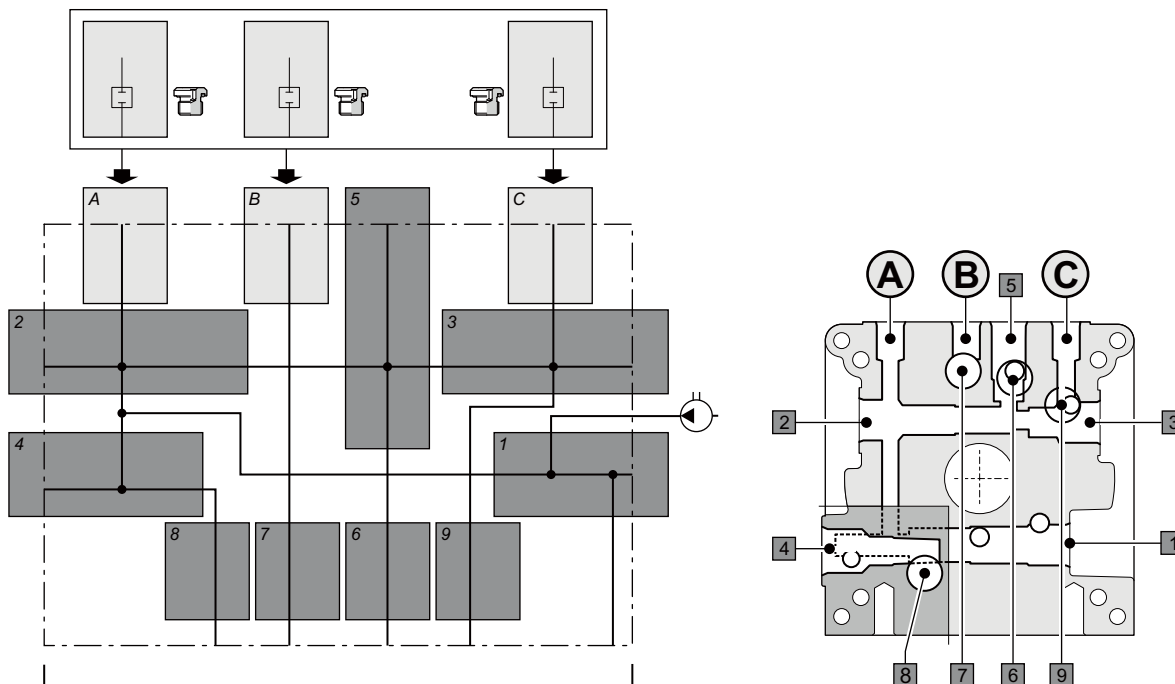

II
FPL

-** Combinations plugs on ports A-B-C-D

-**	A	B	C	D
-00	↑	⊗	↑	⊗
-01	↑	↑	↑	↑
-03	↑	⊗	↑	↑
-04	↑	↑	↑	⊗

Symbols description

Type	Description	Thread	Code	Symbol	Drawing
⊗	Port closed with plug	G 1/4"	20024000		
↑	Port open		—	—	—

Sect. I - FPE Cavity 1

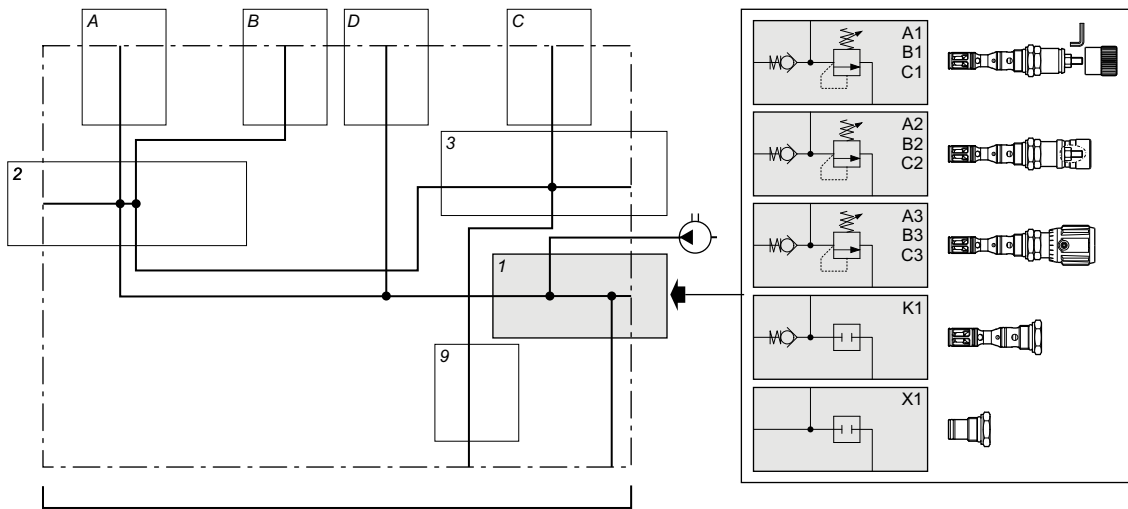
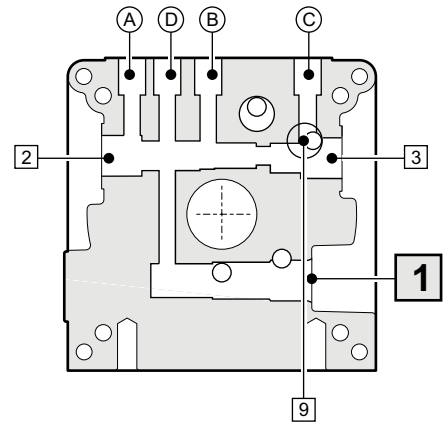
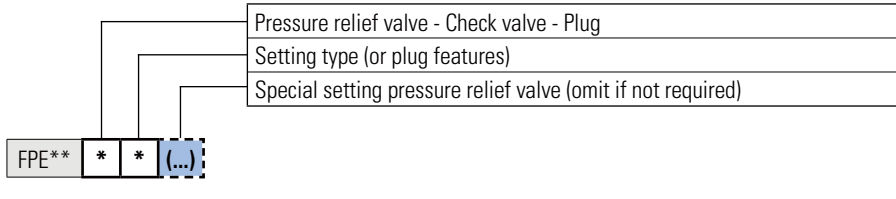

I
FPE

* * (...) **Pressure relief valve with check valve**

*	*	Pressure (bar)	STD setting (bar)	(...) Special setting (bar)	Setting type	Code	Symbol	Drawing
D	1	15 ÷ 50	30	15 ÷ 50 (5 to 5)	Detachable closing	CMPR04S00002		
	2				Non removable closing (1)	CMPR04P00002		
	3				Plastic knob	CMPR04M00002		
E	1	35 ÷ 110	50	35 ÷ 110 (5 to 5)	Detachable closing	CMPR04S01002		
	2				Non removable closing (1)	CMPR04P01002		
	3				Plastic knob	CMPR04M01002		
F	1	75 ÷ 220	150	75 ÷ 220 (5 to 5)	Detachable closing	CMPR04S02002		
	2				Non removable closing (1)	CMPR04P02002		
	3				Plastic knob	CMPR04M02002		
G	1	160 ÷ 290	180	160 ÷ 290 (10 to 10)	Detachable closing	CMPR04S03002		
	2				Non removable closing (1)	CMPR04P03002		
	3				Plastic knob	CMPR04M03002		

1 = Supplied assembled. Unassembled, see accessories page 89

* * **Check valve and plug**

*	*	Description	Code	Symbol	Drawing
K	1	Check valve - Opening pressure 0.5 bar	CR10400001		
X	1	Plug	R78150100		

Sect. II - FPE Cavity 2

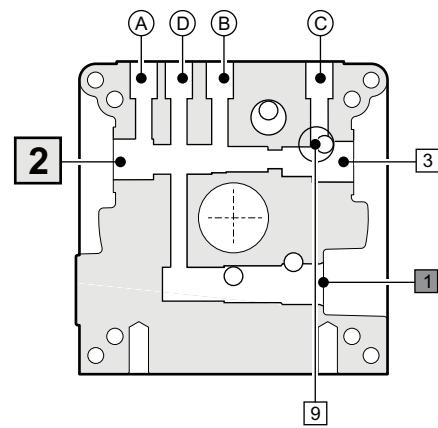
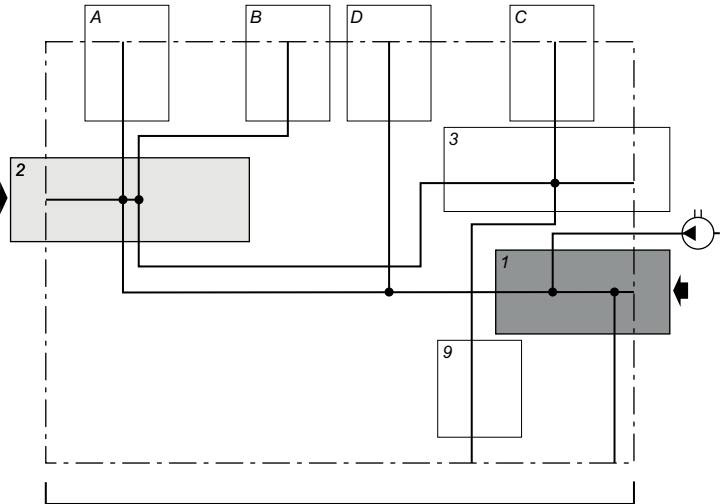
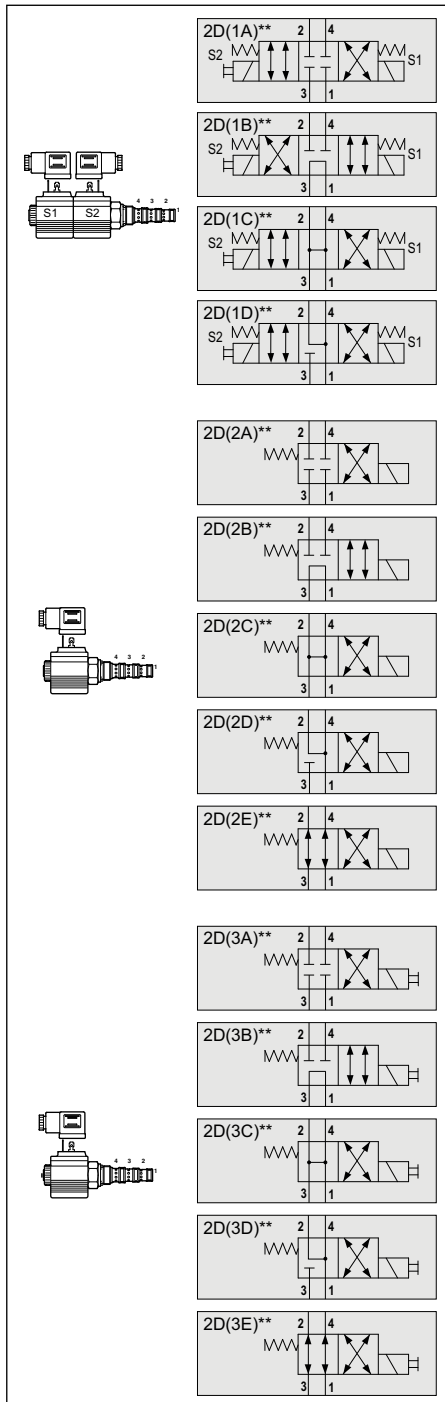
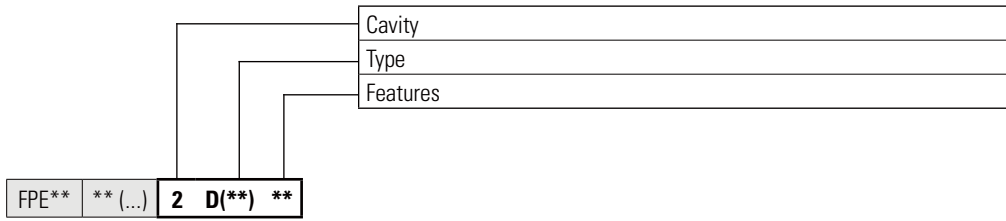

2 D(**) ** Solenoid valves 4 way 3 positions with emergency (1)

(**)	Description	Code (valve + connectors)	Symbol	Drawing
(1A)AA	Voltage 12 Vdc (closed centre "C" spool)	C4V0422C3FEL001 + V86050002 (x2)		
(1A)AB	Voltage 24 Vdc (closed centre "C" spool)	C4V0422C3FEM001 + V86050002 (x2)		
(1B)AA	Voltage 12 Vdc (open centre "A" spool)	C4V0422A3FEL001 + V86050002 (x2)		
(1B)AB	Voltage 24 Vdc (open centre "A" spool)	C4V0422A3FEM001 + V86050002 (x2)		
(1C)AA	Voltage 12 Vdc (centre "H" spool)	C4V0422H3FEL001 + V86050002 (x2)		
(1C)AB	Voltage 24 Vdc (centre "H" spool)	C4V0422H3FEM001 + V86050002 (x2)		
(1D)AA	Voltage 12 Vdc (centre "Y" spool)	C4V0422Y3FEL001 + V86050002 (x2)		
(1D)AB	Voltage 24 Vdc (centre "Y" spool)	C4V0422Y3FEM001 + V86050002 (x2)		

2 D(**) ** Solenoid valves 4 way 2 positions without emergency (1)

(**)	Description	Code (valve + connector)	Symbol	Drawing
(2A)AA	Voltage 12 Vdc (closed centre "C" spool)	C4V0422C2FSL001 + V86050002		
(2A)AB	Voltage 24 Vdc (closed centre "C" spool)	C4V0422C2FSM001 + V86050002		
(2B)AA	Voltage 12 Vdc (open centre "A" spool)	C4V0422A2FSL001 + V86050002		
(2B)AB	Voltage 24 Vdc (open centre "A" spool)	C4V0422A2FSM001 + V86050002		
(2C)AA	Voltage 12 Vdc (centre "H" spool)	C4V0422H2FSL001 + V86050002		
(2C)AB	Voltage 24 Vdc (centre "H" spool)	C4V0422H2FSM001 + V86050002		
(2D)AA	Voltage 12 Vdc (centre "Y" spool)	C4V0422Y2FSL001 + V86050002		
(2D)AB	Voltage 24 Vdc (centre "Y" spool)	C4V0422Y2FSM001 + V86050002		
(2E)AA	Voltage 12 Vdc (direct "D" spool)	C4V0422D2FSL001 + V86050002		
(2E)AB	Voltage 24 Vdc (direct "D" spool)	C4V0422D2FSM001 + V86050002		

2 D(**) ** Solenoid valves 4 way 2 positions with emergency (1)

(**)	Description	Code (valve + connector)	Symbol	Drawing
(3A)AA	Voltage 12 Vdc (closed centre "C" spool)	C4V0422C2FEL001 + V86050002		
(3A)AB	Voltage 24 Vdc (closed centre "C" spool)	C4V0422C2FEM001 + V86050002		
(3B)AA	Voltage 12 Vdc (open centre "A" spool)	C4V0422A2FEL001 + V86050002		
(3B)AB	Voltage 24 Vdc (open centre "A" spool)	C4V0422A2FEM001 + V86050002		
(3C)AA	Voltage 12 Vdc (centre "H" spool)	C4V0422H2FEL001 + V86050002		
(3C)AB	Voltage 24 Vdc (centre "H" spool)	C4V0422H2FEM001 + V86050002		
(3D)AA	Voltage 12 Vdc (centre "Y" spool)	C4V0422Y2FEL001 + V86050002		
(3D)AB	Voltage 24 Vdc (centre "Y" spool)	C4V0422Y2FEM001 + V86050002		
(3E)AA	Voltage 12 Vdc (direct "D" spool)	C4V0422D2FEL001 + V86050002		
(3E)AB	Voltage 24 Vdc (direct "D" spool)	C4V0422D2FEM001 + V86050002		

1 = Valves supplied with connector. Without connector see accessories page 89

Sect. II - FPE Cavity 3

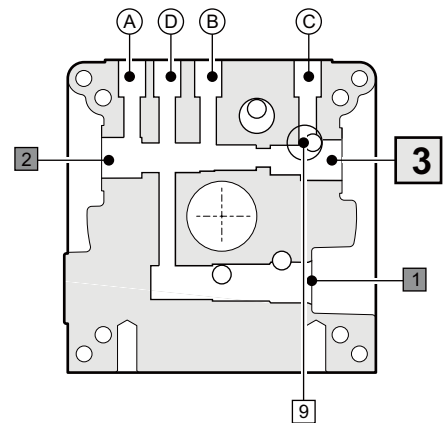
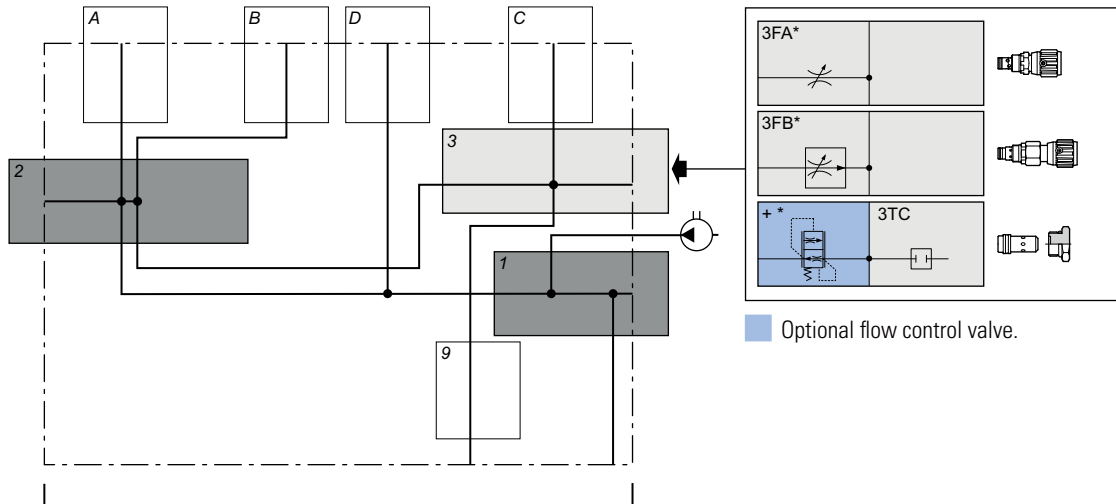
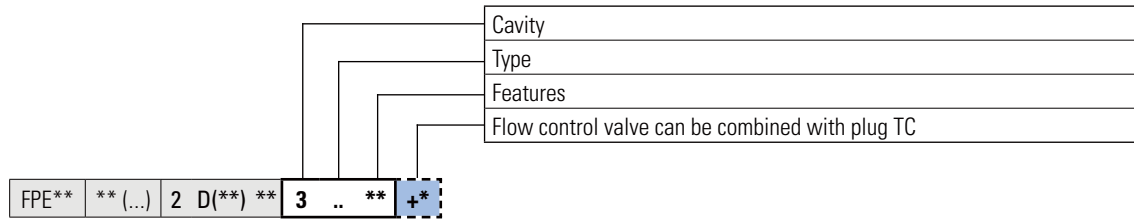

3 FA * *Bidirectional flow control valves not compensated*

*	Description	Code (valve + connector)	Symbol	Drawing
A	Screw adjustment	C SB04C0000		
B	Plastic knob adjustment	C SB04V0000		

3 FB * *Unidirectional flow control valves compensated*

*	Description	Code (valve + connector)	Symbol	Drawing
A	Screw adjustment	C SC04C0000		
B	Plastic knob adjustment	C SC04V0000		

3 T * *Plug*

**	Description	Code	Symbol	Drawing
C	Plug 3/4 16 UNF (1)	R78150099		

3 T C *Flow control valves (1)*

*	Flow	Code	Symbol	Drawing
+B	1.4 l/min	VSC040101		
+C	2.3 l/min	VSC040201		
+E	2.8 l/min	VSC040301		
+G	4.3 l/min	VSC040401		
+J	5.2 l/min	VSC040601		
+L	6.5 l/min	VSC040801		
+N	8.0 l/min	VSC041101		
+Q	11.1 l/min	VSC041601		

(1) The flow control valves can be installed with the plug TC.

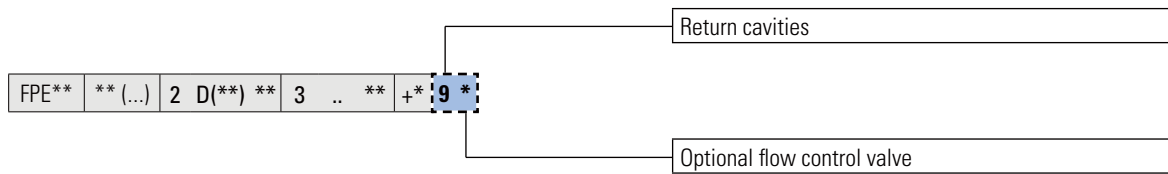

Return cavity, omit if not required flow control valves.

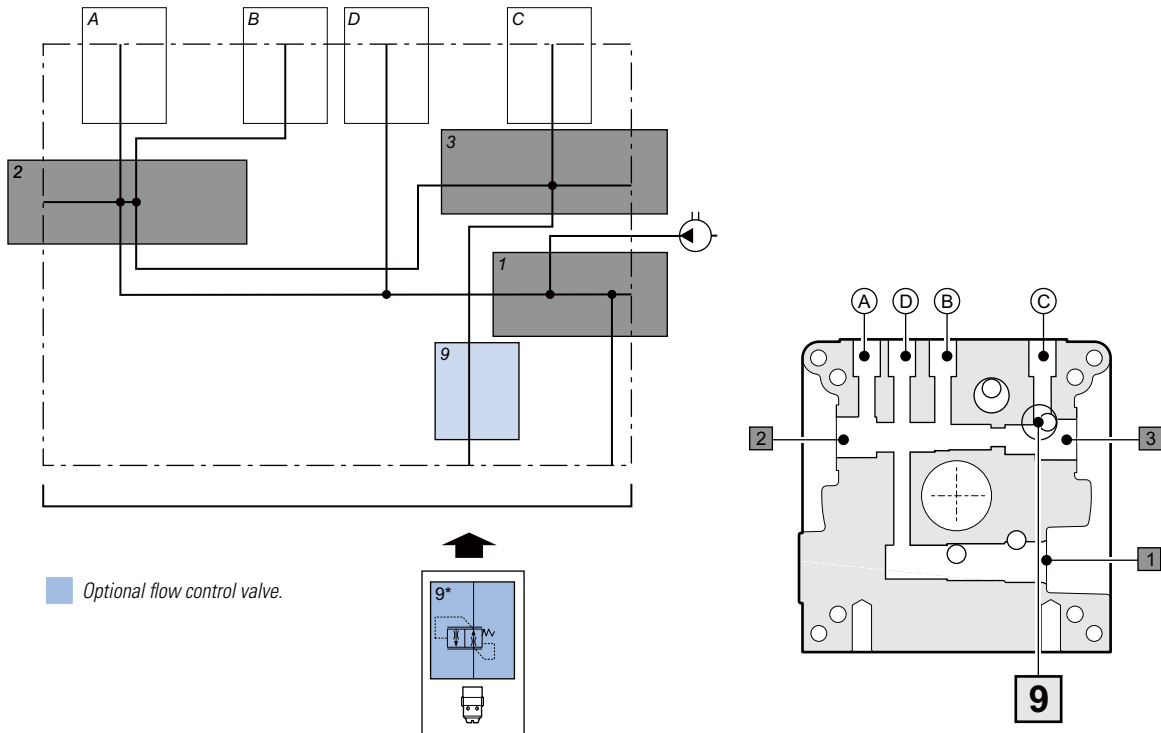

II
FPE

9 * Flow control valves

*	Nominal flow at 120 bar	Code	Symbol	Drawing
A	0.7 l/min	VSC06100002		
B	1.1 l/min	VSC06120002		
C	2.1 l/min	VSC06130002		
E	3.2 l/min	VSC06150002		
G	4.7 l/min	VSC06190002		
K	6.3 l/min	VSC06220002		
N	7.5 l/min	VSC06240002		
Q	10.0 l/min	VSC06280002		
U	13.2 l/min	VSC06330002		
V	15.7 l/min	VSC06350002		

Sect. II - FTE Ports A-B-C-D



Combinations plugs on ports
End section II

FPE** ** (...) 2 D(**) ** 3 .. ** +* 9 * **-**** -

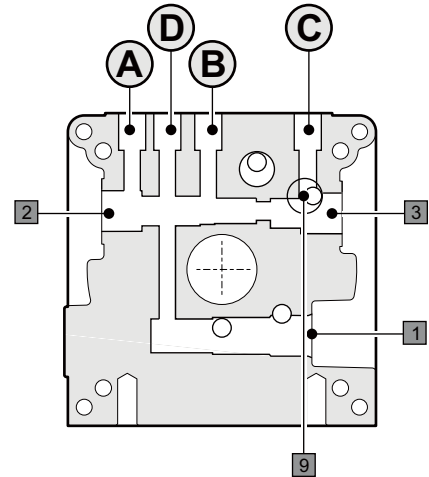
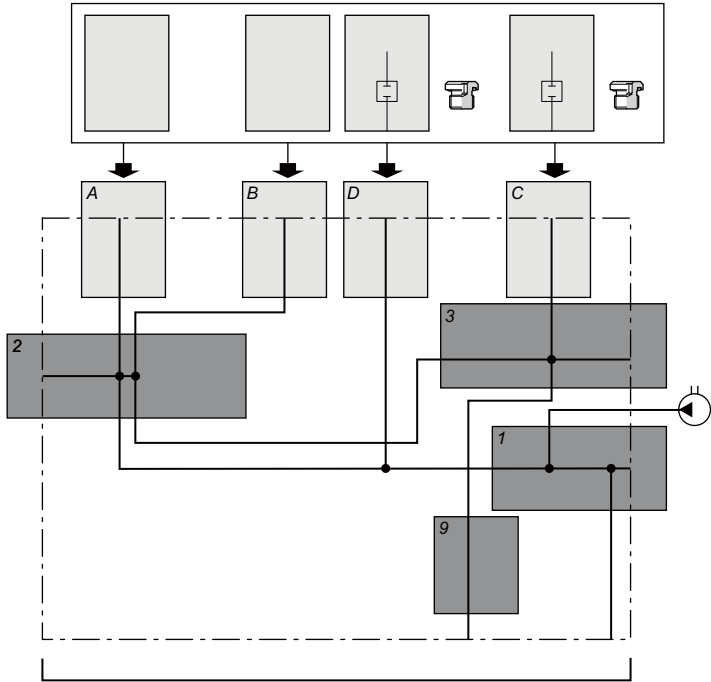

II
FPE

-** Combinations plugs on ports A-B-C-D

-**	A	B	C	D
-00	↑	↑	⊗	↑
-01	↑	↑	↑	⊗
-03	↑	⊗	↑	⊗
-04	↑	↑	⊗	⊗

Symbols description

Type	Description	Thread	Code	Symbol	Drawing
⊗	Port closed with plug	G 1/4"	20024000		
↑	Port open		—	—	—

With the FPE hydraulic power pack, cannot be mounted the standard blocks.

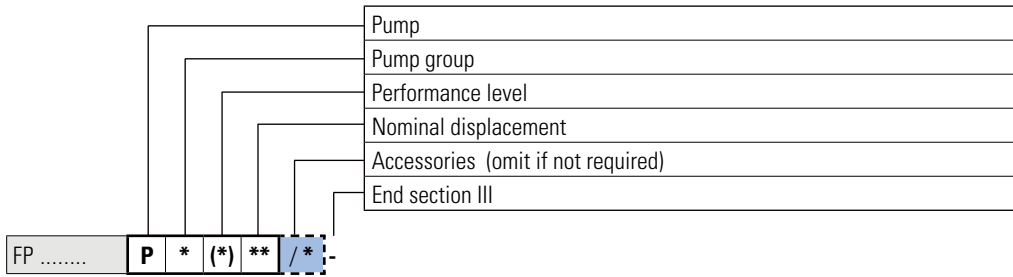

P 0 (1) ** **Pumps group 05 - Performance level 1**

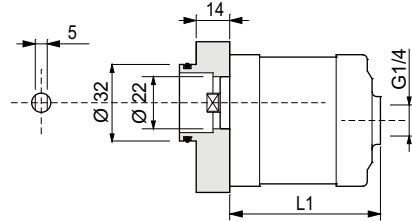

**	Nominal displacement	Tolerance on geometric displacement	P2 bar	P3 bar	Code complete kit	L1 mm	Tanks not compatible (•)				Motors not compatible
							S01A	S09E	S02G	All	
							(H) (V)	(H) (V)	(H) (V)	(H) (V)	
02	0.25 cc	0.25 ÷ 0.33	230	270	17050037.035	54					M4FB(1) - M4GJ(1) MM*PA(1) M*AA(1)D - M*AA(1)G M*AA(1)H M*AB(1)D - M*AB(1)G M*AB(1)H
04	0.45 cc	0.45 ÷ 0.55	230	270	17050036.035	55.7					
05	0.56 cc	0.56 ÷ 0.68	230	270	17050039.035	56.7		•	•		
07	0.75 cc	0.69 ÷ 0.82	230	270	17050038.035	58.5		•	•		
09	0.92 cc	0.83 ÷ 0.95	230	270	17050053.035	59.8		•	•		

P2 = Intermittent operating pressure
 P3 = Intermittent peak pressure (20 sec. max)

Tanks not compatible (as dimensions, see page 55)
 Motors not compatible (interface and transmission not supplied, see pages 71 - 77)

P 1 (1) ** **Pumps group 1 - Performance level 1**

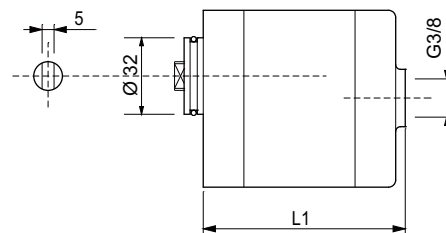

**	Nominal displacement	Tolerance on geometric displacement	P2 bar	P3 bar	Code complete kit	L1 mm	Tanks not compatible (•)				
							S01A	S09E	S02G	All	
							(H) (V)	(H) (V)	(H) (V)	(H) (V)	
07	0.80 cc	0.69 ÷ 0.82	170	210	17050107.018	72.4		•			
10	1.00 cc	0.96 ÷ 1.09	170	210	17050088.018	73.5		•			
12	1.20 cc	1.10 ÷ 1.30	250	290	17050005.018	74.8		•			
17	1.70 cc	1.50 ÷ 1.70	250	290	17050006.018	76.2		•			
22	2.20 cc	2.10 ÷ 2.30	250	290	17050007.018	78.2		•			
26	2.60 cc	2.50 ÷ 2.70	250	290	17050008.018	79.7		•	•		
32	3.20 cc	3.10 ÷ 3.32	250	290	17050009.018	82.0		•	•		
38	3.80 cc	3.60 ÷ 3.99	250	290	17050010.018	84.0		•	•		
43	4.30 cc	4.00 ÷ 4.35	250	290	17050011.018	86.6		•	•		
48	4.80 cc	4.85 ÷ 4.95	225	260	17050033.018	88.1		•	•		
60	6.00 cc	5.62 ÷ 6.02	185	215	17050012.018	92.2	•	•	•	•	
78	7.80 cc	7.48 ÷ 7.90	140	160	17050013.018	98.9	•	•	•	•	
98	9.80 cc	9.60 ÷ 10.00	110	125	17050054.018	107.2	•	•	•	•	

P2 = Intermittent operating pressure
 P3 = Intermittent peak pressure (20 sec. max)

Tanks not compatible (as dimensions, see page 55).

P 1 (1) ** / * **Accessories for pumps group 1**

Displacement

*	Description	Type	Code	Symbol
/A	Single-phase motor start valve - on auxiliary outlet	0.8 ÷ 2.5 l/min	VAM0400L	
/B		> 2.5 ÷ 8.0 l/min	VAM0400M	
/C		> 8.0 ÷ 14 l/min	VAM0400H	
/D	Soft start valve - on auxiliary outlet	hole Ø 0.4 mm	VAMS0404001	

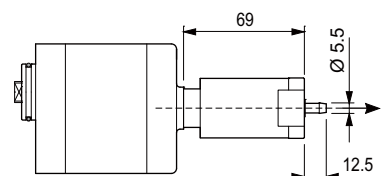
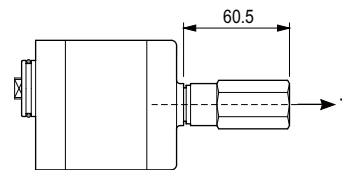

**	With accessory	Tanks not compatible (•)			
		S01A	S09E	S02G	All
09	/A /B /C /D	•	•	•	
12	/A /B /C /D	•	•	•	
17	/A /B /C /D	•	•	•	
22	/A /B /C /D	•	•	•	
26	/A /B /C /D	•	•	•	
32	/A /B /C /D	•	•	•	
38	/A /B /C /D	•	•	•	
43	/A /B /C /D	•	•	•	

Tanks not compatible (as dimensions, see page 55).

Sect. IV - Tanks / Sect. V - Tubes kit



Tank (**S** = with tank and tubes kit; **G** = only tubes kit, without tank; **OMIT** if without tank and without tubes kit)
 Capacity liters
 Features (material and construction)
 Mounting position: (**H** = horizontal; **V** = vertical)
 Variants (**00** = standard, no variant) - **OMIT if with tubes kit**
 Orientation - **OMIT if with tubes kit in vertical mounting position**
 End section IV and V

FP * ** * (*) ** /* -

**	Liters	* Dimensions (mm)	Material	(*) Mounting	** Variants	Page	* Orientation	Page																																																																																																																																																																																																																					
01	1	A Ø 123 - L 141	Sheet steel	(H)	00	56																																																																																																																																																																																																																							
				(V)	00				02	1,5	G ∅ 130x140 - L 135	Polyethylene	(H)	00	65	(V)	00	02	2	A Ø 123 - L 200	Sheet steel	(H)	00	56	(V)	00	03	2,5	G ∅ 130x140 - L 235	Polyethylene	(H)	00	65	(V)	00	03	3	A Ø 123 - L 330	Sheet steel	(H)	00	56	(V)	00	04	4	G ∅ 130x140 - L 295	Polyethylene	(H)	00	65	(V)	00	04	4	L ∅ 180 - L 210	Polyethylene	(H)	00	66	(V)	00	05	5	B Ø 175 - L 246	Sheet steel	(H)	00-01-02-03-04	57	(V)	00	05	5	C Ø 200 - L 210	Sheet steel	(H)	00	58	(V)	00	05	5	F ∅ 180 - L 240	Polypropylene	(H)	00	64	(V)	00	06	6	B Ø 175 - L 308	Sheet steel	(H)	00-04	57	(V)	00	07	7	E ∅ 154x188 - L 299	Sheet steel	(V)	00-01	60	(H)	00	(V)	00	(H)	00	07	7	F ∅ 180 - L 308	Polypropylene	(V)	00	64	(H)	00	07	7	L ∅ 180 - L 310	Polyethylene	(H)	00	67	(V)	00	07	7	M ∅ 180 - L 335	Polietilene	(H)	00	68	(V)	00	08	8	B Ø 175 - L 370	Sheet steel	(H)	00-04	57	(V)	00	08	8	C Ø 200 - L 306	Sheet steel	(H)	00	58	(V)	00	09	9	E ∅ 230x130 - L 350	Sheet steel	(H)	00	61	(V)	00	09	9	L ∅ 180 - L 370	Polietilene	(V)	00	67	(H)	00	10	10	C Ø 200 - L 373	Sheet steel	(H)	00	58	(V)	00	10	10	D Ø 217 - L 273	Sheet steel	(H)	00	59	(V)	00	10	10	L ∅ 180 - L 410	Polyethylene	(H)	00	67	(V)	00	12	12	D Ø 217 - L 370	Sheet steel	(H)	00	59	(V)	00	14	14	E ∅ 255x193 - L 366	Sheet steel	(V)	00-01	62	25	25	E ∅ 250x255 - L 436	Sheet steel
02	1,5	G ∅ 130x140 - L 135	Polyethylene	(H)	00	65																																																																																																																																																																																																																							
				(V)	00				02	2	A Ø 123 - L 200	Sheet steel	(H)	00	56	(V)	00	03	2,5	G ∅ 130x140 - L 235	Polyethylene	(H)	00	65	(V)	00	03	3	A Ø 123 - L 330	Sheet steel	(H)	00	56	(V)	00	04	4	G ∅ 130x140 - L 295	Polyethylene	(H)	00	65	(V)	00	04	4	L ∅ 180 - L 210	Polyethylene	(H)	00	66	(V)	00	05	5	B Ø 175 - L 246	Sheet steel	(H)	00-01-02-03-04	57	(V)	00	05	5	C Ø 200 - L 210	Sheet steel	(H)	00	58	(V)	00	05	5	F ∅ 180 - L 240	Polypropylene	(H)	00	64	(V)	00	06	6	B Ø 175 - L 308	Sheet steel	(H)	00-04	57	(V)	00	07	7	E ∅ 154x188 - L 299	Sheet steel	(V)	00-01	60	(H)	00					(V)	00		(H)	00	07	7	F ∅ 180 - L 308	Polypropylene	(V)	00	64	(H)	00	07	7	L ∅ 180 - L 310	Polyethylene	(H)	00	67	(V)	00	07	7	M ∅ 180 - L 335	Polietilene	(H)	00	68	(V)	00	08	8	B Ø 175 - L 370	Sheet steel	(H)	00-04	57	(V)	00	08	8	C Ø 200 - L 306	Sheet steel	(H)	00	58	(V)	00	09	9	E ∅ 230x130 - L 350	Sheet steel	(H)	00	61	(V)	00	09	9	L ∅ 180 - L 370	Polietilene	(V)	00	67	(H)	00	10	10	C Ø 200 - L 373	Sheet steel	(H)	00	58	(V)	00	10	10	D Ø 217 - L 273	Sheet steel	(H)	00	59	(V)	00	10	10	L ∅ 180 - L 410	Polyethylene	(H)	00	67	(V)	00	12	12	D Ø 217 - L 370	Sheet steel	(H)	00	59	(V)	00	14	14	E ∅ 255x193 - L 366	Sheet steel	(V)	00-01	62	25	25	E ∅ 250x255 - L 436	Sheet steel	(H)	00-01	63	(V)
02	2	A Ø 123 - L 200	Sheet steel	(H)	00	56																																																																																																																																																																																																																							
				(V)	00				03	2,5	G ∅ 130x140 - L 235	Polyethylene	(H)	00	65	(V)	00	03	3	A Ø 123 - L 330	Sheet steel	(H)	00	56	(V)	00	04	4	G ∅ 130x140 - L 295	Polyethylene	(H)	00	65	(V)	00	04	4	L ∅ 180 - L 210	Polyethylene	(H)	00	66	(V)	00	05	5	B Ø 175 - L 246	Sheet steel	(H)	00-01-02-03-04	57	(V)	00	05	5	C Ø 200 - L 210	Sheet steel	(H)	00	58	(V)	00	05	5	F ∅ 180 - L 240	Polypropylene	(H)	00	64	(V)	00	06	6	B Ø 175 - L 308	Sheet steel	(H)	00-04	57	(V)	00	07	7	E ∅ 154x188 - L 299	Sheet steel	(V)	00-01	60	(H)	00					(V)	00		(H)	00	07	7	F ∅ 180 - L 308	Polypropylene	(V)	00	64	(H)	00	07	7	L ∅ 180 - L 310	Polyethylene	(H)	00	67	(V)	00	07	7	M ∅ 180 - L 335	Polietilene	(H)	00	68	(V)	00	08	8	B Ø 175 - L 370	Sheet steel	(H)	00-04	57	(V)	00	08	8	C Ø 200 - L 306	Sheet steel	(H)	00	58	(V)	00	09	9	E ∅ 230x130 - L 350	Sheet steel	(H)	00	61	(V)	00	09	9	L ∅ 180 - L 370	Polietilene	(V)	00	67	(H)	00	10	10	C Ø 200 - L 373	Sheet steel	(H)	00	58	(V)	00	10	10	D Ø 217 - L 273	Sheet steel	(H)	00	59	(V)	00	10	10	L ∅ 180 - L 410	Polyethylene	(H)	00	67	(V)	00	12	12	D Ø 217 - L 370	Sheet steel	(H)	00	59	(V)	00	14	14	E ∅ 255x193 - L 366	Sheet steel	(V)	00-01	62	25	25	E ∅ 250x255 - L 436	Sheet steel	(H)	00-01	63	(V)	00-01								
03	2,5	G ∅ 130x140 - L 235	Polyethylene	(H)	00	65																																																																																																																																																																																																																							
				(V)	00				03	3	A Ø 123 - L 330	Sheet steel	(H)	00	56	(V)	00	04	4	G ∅ 130x140 - L 295	Polyethylene	(H)	00	65	(V)	00	04	4	L ∅ 180 - L 210	Polyethylene	(H)	00	66	(V)	00	05	5	B Ø 175 - L 246	Sheet steel	(H)	00-01-02-03-04	57	(V)	00	05	5	C Ø 200 - L 210	Sheet steel	(H)	00	58	(V)	00	05	5	F ∅ 180 - L 240	Polypropylene	(H)	00	64	(V)	00	06	6	B Ø 175 - L 308	Sheet steel	(H)	00-04	57	(V)	00	07	7	E ∅ 154x188 - L 299	Sheet steel	(V)	00-01	60	(H)	00					(V)	00		(H)	00	07	7	F ∅ 180 - L 308	Polypropylene	(V)	00	64	(H)	00	07	7	L ∅ 180 - L 310	Polyethylene	(H)	00	67	(V)	00	07	7	M ∅ 180 - L 335	Polietilene	(H)	00	68	(V)	00	08	8	B Ø 175 - L 370	Sheet steel	(H)	00-04	57	(V)	00	08	8	C Ø 200 - L 306	Sheet steel	(H)	00	58	(V)	00	09	9	E ∅ 230x130 - L 350	Sheet steel	(H)	00	61	(V)	00	09	9	L ∅ 180 - L 370	Polietilene	(V)	00	67	(H)	00	10	10	C Ø 200 - L 373	Sheet steel	(H)	00	58	(V)	00	10	10	D Ø 217 - L 273	Sheet steel	(H)	00	59	(V)	00	10	10	L ∅ 180 - L 410	Polyethylene	(H)	00	67	(V)	00	12	12	D Ø 217 - L 370	Sheet steel	(H)	00	59	(V)	00	14	14	E ∅ 255x193 - L 366	Sheet steel	(V)	00-01	62	25	25	E ∅ 250x255 - L 436	Sheet steel	(H)	00-01	63	(V)	00-01																	
03	3	A Ø 123 - L 330	Sheet steel	(H)	00	56																																																																																																																																																																																																																							
				(V)	00				04	4	G ∅ 130x140 - L 295	Polyethylene	(H)	00	65	(V)	00	04	4	L ∅ 180 - L 210	Polyethylene	(H)	00	66	(V)	00	05	5	B Ø 175 - L 246	Sheet steel	(H)	00-01-02-03-04	57	(V)	00	05	5	C Ø 200 - L 210	Sheet steel	(H)	00	58	(V)	00	05	5	F ∅ 180 - L 240	Polypropylene	(H)	00	64	(V)	00	06	6	B Ø 175 - L 308	Sheet steel	(H)	00-04	57	(V)	00	07	7	E ∅ 154x188 - L 299	Sheet steel	(V)	00-01	60	(H)	00					(V)	00		(H)	00	07	7	F ∅ 180 - L 308	Polypropylene	(V)	00	64	(H)	00	07	7	L ∅ 180 - L 310	Polyethylene	(H)	00	67	(V)	00	07	7	M ∅ 180 - L 335	Polietilene	(H)	00	68	(V)	00	08	8	B Ø 175 - L 370	Sheet steel	(H)	00-04	57	(V)	00	08	8	C Ø 200 - L 306	Sheet steel	(H)	00	58	(V)	00	09	9	E ∅ 230x130 - L 350	Sheet steel	(H)	00	61	(V)	00	09	9	L ∅ 180 - L 370	Polietilene	(V)	00	67	(H)	00	10	10	C Ø 200 - L 373	Sheet steel	(H)	00	58	(V)	00	10	10	D Ø 217 - L 273	Sheet steel	(H)	00	59	(V)	00	10	10	L ∅ 180 - L 410	Polyethylene	(H)	00	67	(V)	00	12	12	D Ø 217 - L 370	Sheet steel	(H)	00	59	(V)	00	14	14	E ∅ 255x193 - L 366	Sheet steel	(V)	00-01	62	25	25	E ∅ 250x255 - L 436	Sheet steel	(H)	00-01	63	(V)	00-01																										
04	4	G ∅ 130x140 - L 295	Polyethylene	(H)	00	65																																																																																																																																																																																																																							
				(V)	00				04	4	L ∅ 180 - L 210	Polyethylene	(H)	00	66	(V)	00	05	5	B Ø 175 - L 246	Sheet steel	(H)	00-01-02-03-04	57	(V)	00	05	5	C Ø 200 - L 210	Sheet steel	(H)	00	58	(V)	00	05	5	F ∅ 180 - L 240	Polypropylene	(H)	00	64	(V)	00	06	6	B Ø 175 - L 308	Sheet steel	(H)	00-04	57	(V)	00	07	7	E ∅ 154x188 - L 299	Sheet steel	(V)	00-01	60	(H)	00					(V)	00		(H)	00	07	7	F ∅ 180 - L 308	Polypropylene	(V)	00	64	(H)	00	07	7	L ∅ 180 - L 310	Polyethylene	(H)	00	67	(V)	00	07	7	M ∅ 180 - L 335	Polietilene	(H)	00	68	(V)	00	08	8	B Ø 175 - L 370	Sheet steel	(H)	00-04	57	(V)	00	08	8	C Ø 200 - L 306	Sheet steel	(H)	00	58	(V)	00	09	9	E ∅ 230x130 - L 350	Sheet steel	(H)	00	61	(V)	00	09	9	L ∅ 180 - L 370	Polietilene	(V)	00	67	(H)	00	10	10	C Ø 200 - L 373	Sheet steel	(H)	00	58	(V)	00	10	10	D Ø 217 - L 273	Sheet steel	(H)	00	59	(V)	00	10	10	L ∅ 180 - L 410	Polyethylene	(H)	00	67	(V)	00	12	12	D Ø 217 - L 370	Sheet steel	(H)	00	59	(V)	00	14	14	E ∅ 255x193 - L 366	Sheet steel	(V)	00-01	62	25	25	E ∅ 250x255 - L 436	Sheet steel	(H)	00-01	63	(V)	00-01																																			
04	4	L ∅ 180 - L 210	Polyethylene	(H)	00	66																																																																																																																																																																																																																							
				(V)	00				05	5	B Ø 175 - L 246	Sheet steel	(H)	00-01-02-03-04	57	(V)	00	05	5	C Ø 200 - L 210	Sheet steel	(H)	00	58	(V)	00	05	5	F ∅ 180 - L 240	Polypropylene	(H)	00	64	(V)	00	06	6	B Ø 175 - L 308	Sheet steel	(H)	00-04	57	(V)	00	07	7	E ∅ 154x188 - L 299	Sheet steel	(V)	00-01	60	(H)	00					(V)	00		(H)	00	07	7	F ∅ 180 - L 308	Polypropylene	(V)	00	64	(H)	00	07	7	L ∅ 180 - L 310	Polyethylene	(H)	00	67	(V)	00	07	7	M ∅ 180 - L 335	Polietilene	(H)	00	68	(V)	00	08	8	B Ø 175 - L 370	Sheet steel	(H)	00-04	57	(V)	00	08	8	C Ø 200 - L 306	Sheet steel	(H)	00	58	(V)	00	09	9	E ∅ 230x130 - L 350	Sheet steel	(H)	00	61	(V)	00	09	9	L ∅ 180 - L 370	Polietilene	(V)	00	67	(H)	00	10	10	C Ø 200 - L 373	Sheet steel	(H)	00	58	(V)	00	10	10	D Ø 217 - L 273	Sheet steel	(H)	00	59	(V)	00	10	10	L ∅ 180 - L 410	Polyethylene	(H)	00	67	(V)	00	12	12	D Ø 217 - L 370	Sheet steel	(H)	00	59	(V)	00	14	14	E ∅ 255x193 - L 366	Sheet steel	(V)	00-01	62	25	25	E ∅ 250x255 - L 436	Sheet steel	(H)	00-01	63	(V)	00-01																																												
05	5	B Ø 175 - L 246	Sheet steel	(H)	00-01-02-03-04	57																																																																																																																																																																																																																							
				(V)	00				05	5	C Ø 200 - L 210	Sheet steel	(H)	00	58	(V)	00	05	5	F ∅ 180 - L 240	Polypropylene	(H)	00	64	(V)	00	06	6	B Ø 175 - L 308	Sheet steel	(H)	00-04	57	(V)	00	07	7	E ∅ 154x188 - L 299	Sheet steel	(V)	00-01	60	(H)	00					(V)	00		(H)	00	07	7	F ∅ 180 - L 308	Polypropylene	(V)	00	64	(H)	00	07	7	L ∅ 180 - L 310	Polyethylene	(H)	00	67	(V)	00	07	7	M ∅ 180 - L 335	Polietilene	(H)	00	68	(V)	00	08	8	B Ø 175 - L 370	Sheet steel	(H)	00-04	57	(V)	00	08	8	C Ø 200 - L 306	Sheet steel	(H)	00	58	(V)	00	09	9	E ∅ 230x130 - L 350	Sheet steel	(H)	00	61	(V)	00	09	9	L ∅ 180 - L 370	Polietilene	(V)	00	67	(H)	00	10	10	C Ø 200 - L 373	Sheet steel	(H)	00	58	(V)	00	10	10	D Ø 217 - L 273	Sheet steel	(H)	00	59	(V)	00	10	10	L ∅ 180 - L 410	Polyethylene	(H)	00	67	(V)	00	12	12	D Ø 217 - L 370	Sheet steel	(H)	00	59	(V)	00	14	14	E ∅ 255x193 - L 366	Sheet steel	(V)	00-01	62	25	25	E ∅ 250x255 - L 436	Sheet steel	(H)	00-01	63	(V)	00-01																																																					
05	5	C Ø 200 - L 210	Sheet steel	(H)	00	58																																																																																																																																																																																																																							
				(V)	00				05	5	F ∅ 180 - L 240	Polypropylene	(H)	00	64	(V)	00	06	6	B Ø 175 - L 308	Sheet steel	(H)	00-04	57	(V)	00	07	7	E ∅ 154x188 - L 299	Sheet steel	(V)	00-01	60	(H)	00					(V)	00		(H)	00	07	7	F ∅ 180 - L 308	Polypropylene	(V)	00	64	(H)	00	07	7	L ∅ 180 - L 310	Polyethylene	(H)	00	67	(V)	00	07	7	M ∅ 180 - L 335	Polietilene	(H)	00	68	(V)	00	08	8	B Ø 175 - L 370	Sheet steel	(H)	00-04	57	(V)	00	08	8	C Ø 200 - L 306	Sheet steel	(H)	00	58	(V)	00	09	9	E ∅ 230x130 - L 350	Sheet steel	(H)	00	61	(V)	00	09	9	L ∅ 180 - L 370	Polietilene	(V)	00	67	(H)	00	10	10	C Ø 200 - L 373	Sheet steel	(H)	00	58	(V)	00	10	10	D Ø 217 - L 273	Sheet steel	(H)	00	59	(V)	00	10	10	L ∅ 180 - L 410	Polyethylene	(H)	00	67	(V)	00	12	12	D Ø 217 - L 370	Sheet steel	(H)	00	59	(V)	00	14	14	E ∅ 255x193 - L 366	Sheet steel	(V)	00-01	62	25	25	E ∅ 250x255 - L 436	Sheet steel	(H)	00-01	63	(V)	00-01																																																														
05	5	F ∅ 180 - L 240	Polypropylene	(H)	00	64																																																																																																																																																																																																																							
				(V)	00				06	6	B Ø 175 - L 308	Sheet steel	(H)	00-04	57	(V)	00	07	7	E ∅ 154x188 - L 299	Sheet steel	(V)	00-01	60	(H)	00					(V)	00		(H)	00	07	7	F ∅ 180 - L 308	Polypropylene	(V)	00	64	(H)	00	07	7	L ∅ 180 - L 310	Polyethylene	(H)	00	67	(V)	00	07	7	M ∅ 180 - L 335	Polietilene	(H)	00	68	(V)	00	08	8	B Ø 175 - L 370	Sheet steel	(H)	00-04	57	(V)	00	08	8	C Ø 200 - L 306	Sheet steel	(H)	00	58	(V)	00	09	9	E ∅ 230x130 - L 350	Sheet steel	(H)	00	61	(V)	00	09	9	L ∅ 180 - L 370	Polietilene	(V)	00	67	(H)	00	10	10	C Ø 200 - L 373	Sheet steel	(H)	00	58	(V)	00	10	10	D Ø 217 - L 273	Sheet steel	(H)	00	59	(V)	00	10	10	L ∅ 180 - L 410	Polyethylene	(H)	00	67	(V)	00	12	12	D Ø 217 - L 370	Sheet steel	(H)	00	59	(V)	00	14	14	E ∅ 255x193 - L 366	Sheet steel	(V)	00-01	62	25	25	E ∅ 250x255 - L 436	Sheet steel	(H)	00-01	63	(V)	00-01																																																																							
06	6	B Ø 175 - L 308	Sheet steel	(H)	00-04	57																																																																																																																																																																																																																							
				(V)	00		07	7	E ∅ 154x188 - L 299	Sheet steel	(V)	00-01	60	(H)	00	(V)	00					(H)	00		07	7	F ∅ 180 - L 308	Polypropylene	(V)	00	64	(H)	00	07	7	L ∅ 180 - L 310	Polyethylene	(H)	00	67	(V)	00	07	7	M ∅ 180 - L 335	Polietilene	(H)	00	68	(V)	00	08	8	B Ø 175 - L 370	Sheet steel	(H)	00-04	57	(V)	00	08	8	C Ø 200 - L 306	Sheet steel	(H)	00	58	(V)	00	09	9	E ∅ 230x130 - L 350	Sheet steel	(H)	00	61	(V)	00	09	9	L ∅ 180 - L 370	Polietilene	(V)	00	67	(H)	00	10	10	C Ø 200 - L 373	Sheet steel	(H)	00	58	(V)	00	10	10	D Ø 217 - L 273	Sheet steel	(H)	00	59	(V)	00	10	10	L ∅ 180 - L 410	Polyethylene	(H)	00	67	(V)	00	12	12	D Ø 217 - L 370	Sheet steel	(H)	00	59	(V)	00	14	14	E ∅ 255x193 - L 366	Sheet steel	(V)	00-01	62	25	25	E ∅ 250x255 - L 436	Sheet steel	(H)	00-01	63	(V)	00-01																																																																																		
07	7	E ∅ 154x188 - L 299	Sheet steel	(V)	00-01	60																																																																																																																																																																																																																							
				(H)	00																																																																																																																																																																																																																								
				(V)	00																																																																																																																																																																																																																								
				(H)	00																																																																																																																																																																																																																								
07	7	F ∅ 180 - L 308	Polypropylene	(V)	00	64																																																																																																																																																																																																																							
				(H)	00																																																																																																																																																																																																																								
07	7	L ∅ 180 - L 310	Polyethylene	(H)	00	67																																																																																																																																																																																																																							
				(V)	00																																																																																																																																																																																																																								
07	7	M ∅ 180 - L 335	Polietilene	(H)	00	68																																																																																																																																																																																																																							
				(V)	00																																																																																																																																																																																																																								
08	8	B Ø 175 - L 370	Sheet steel	(H)	00-04	57																																																																																																																																																																																																																							
				(V)	00																																																																																																																																																																																																																								
08	8	C Ø 200 - L 306	Sheet steel	(H)	00	58																																																																																																																																																																																																																							
				(V)	00																																																																																																																																																																																																																								
09	9	E ∅ 230x130 - L 350	Sheet steel	(H)	00	61																																																																																																																																																																																																																							
				(V)	00																																																																																																																																																																																																																								
09	9	L ∅ 180 - L 370	Polietilene	(V)	00	67																																																																																																																																																																																																																							
				(H)	00																																																																																																																																																																																																																								
10	10	C Ø 200 - L 373	Sheet steel	(H)	00	58																																																																																																																																																																																																																							
				(V)	00																																																																																																																																																																																																																								
10	10	D Ø 217 - L 273	Sheet steel	(H)	00	59																																																																																																																																																																																																																							
				(V)	00																																																																																																																																																																																																																								
10	10	L ∅ 180 - L 410	Polyethylene	(H)	00	67																																																																																																																																																																																																																							
				(V)	00																																																																																																																																																																																																																								
12	12	D Ø 217 - L 370	Sheet steel	(H)	00	59																																																																																																																																																																																																																							
				(V)	00																																																																																																																																																																																																																								
14	14	E ∅ 255x193 - L 366	Sheet steel	(V)	00-01	62																																																																																																																																																																																																																							
25	25	E ∅ 250x255 - L 436	Sheet steel	(H)	00-01	63																																																																																																																																																																																																																							
				(V)	00-01																																																																																																																																																																																																																								

/1(std)
/2
/3
/4

69

IV
V

Sect. IV - Tanks / Sect. V - Tubes kit



* ** * (H) ** * - Tanks Ø 123 - Sheet steel, capacity 1-2-3 liters - Horizontal mounting (black painted)

Capacity	Features	Mounting	Variant (1)	L (mm)	Capacity (liters)			Tank (with plug)	Tank fixing kit (screws and O-Ring)
					Nominal	Full	Usable		
01				141	1	1.0	0.7	90310000	17010080
02	A	(H)	00	200	2	1.6	1.5	90310001	
03				330	3	3	2.8	90310002	

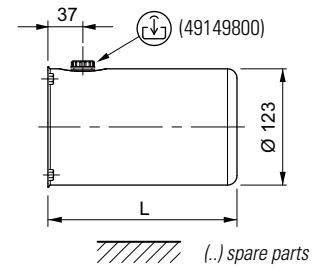

(1) Variant - OMIT if without tank but with tubes kit

Other variants

Variant				Tank				Variant				Tank				Variant				Tank			

* ** * (V) ** * - Tanks Ø 123 - Sheet steel, capacity 1-2-3 liters - Vertical mounting (black painted)

Capacity	Features	Mounting	Variant (1)	L (mm)	Capacity (liters)			Tank (with plug)	Tank fixing kit (screws and O-Ring)
					Nominal	Full	Usable		
01				141	1	0.9	0.7	90310009	17010080
02	A	(V)	00	200	2	1.6	1.5	90310010	
03				330	3	2.9	2.9	90310011	

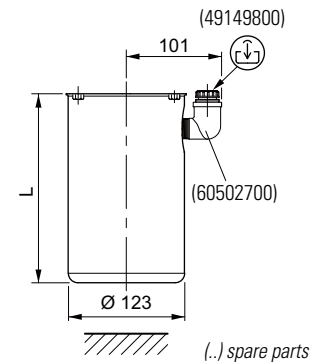

(1) Variant - OMIT if without tank but with tubes kit

Other variants

Variant				Tank				Variant				Tank				Variant				Tank			

Sect. IV - Tanks / Sect. V - Tubes kit



* ** * (H) ** * - Tanks Ø 175 - Sheet steel, capacity 5-6-8 liters - Horizontal mounting (black painted)

Capacity	Features	Mounting	Variant (1)	L (mm)	Capacity (liters)			Tank (with plugs)	Tank fixing kit (screws and O-Ring)
					Nominal	Full	Usable		
05				246	5	4.7	4.5	90310003	17010080
06	B	(H)	00	308	6	6	5.9	90310004	
08				370	8	8	7.3	90310005	

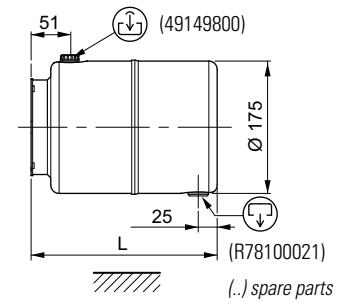

(1) Variant - OMIT if without tank but with tubes kit

Other variants

Variant				Tank		Variant				Tank		Variant				Tank							
05				90310003		05				90310149		05				90310134		05				90310176	
06	B	(H)	01			06	B	(H)	02			06	B	(H)	03			06	B	(H)	04		
08						08						08						08					

--	--	--	--	--	--	--	--	--	--	--	--	--	--	--	--

* ** * (V) ** * - Tanks Ø 175 - Sheet steel, capacity 5-6-8 liters - Vertical mounting (black painted)

Capacity	Features	Mounting	Variant (1)	L (mm)	Capacity (liters)			Tank (with plugs)	Tank fixing kit (screws and O-Ring)
					Nominal	Full	Usable		
05				246	5	4.3	4.1	90310012	17010080
06	B	(V)	00	308	6	5.8	5.5	90310013	
08				370	8	7.5	7.2	90310015	

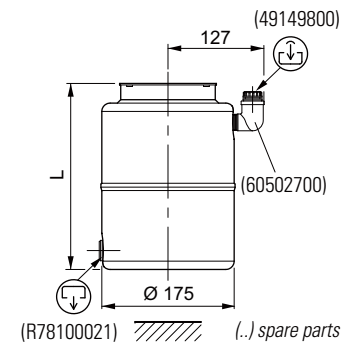

(1) Variant - OMIT if without tank but with tubes kit

Other variants

Variant		Tank		Variant		Tank		Variant		Tank		Variant		Tank	

Sect. IV - Tanks / Sect. V - Tubes kit



* ** * (H) ** * - Tanks Ø 200 - Sheet steel, capacity 5-8-10 liters - Horizontal mounting (black painted)

Capacity	Features	Mounting	Variant (1)	L (mm)	Capacity (liters)			Tank (with plugs)	Tank fixing kit (screws and O-Ring)
					Nominal	Full	Usable		
05				205	5	5.3	5.0	90310425	17010080
08	C	(H)	00	301	8	8.0	7.7	90310428	
10				368	10	10	9.3	90310431	

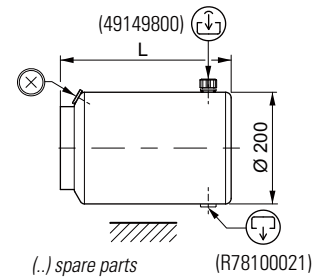

(1) Variant - OMIT if without tank but with tubes kit

Other variants

Variant	Tank	Variant	Tank	Variant	Tank	Variant	Tank
				05	90310453		
				08 C (H) 03	90310443		
				10	90310483		

(49107500) (R78100021)
Ø 200

* ** * (V) ** * - Tanks Ø 200 - Sheet steel, capacity 5-8-10 liters - Vertical mounting (black painted)

Capacity	Features	Mounting	Variant (1)	L (mm)	Capacity (liters)			Tank (with plugs)	Tank fixing kit (screws and O-Ring)
					Nominal	Full	Usable		
05				205	5	4.6	4.3	90310444	17010080
08	C	(V)	00	301	8	7.5	7.1	90310437	
10				368	10	9.5	9.1	90310439	

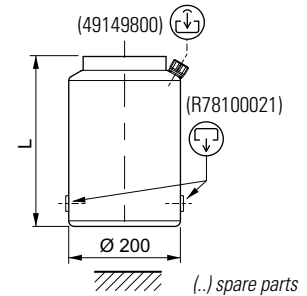

(1) Variant - OMIT if without tank but with tubes kit

Other variants

Variant	Tank	Variant	Tank	Variant	Tank	Variant	Tank

Sect. IV - Tanks / Sect. V - Tubes kit



* ** * (H) ** * - Tanks Ø 217 - Sheet steel, capacity 10-12 liters - Horizontal mounting (black painted)

Capacity	Features	Mounting	Variant (1)	L (mm)	Capacity (liters)			Tank (with plugs)	Tank fixing kit (screws and O-Ring)
					Nominal	Full	Usable		
10	D (H) 00			273	10	8	7.6	90310006	17010080
12				370	12	12	11	90310058	

(1) Variant - OMIT if without tank but with tubes kit

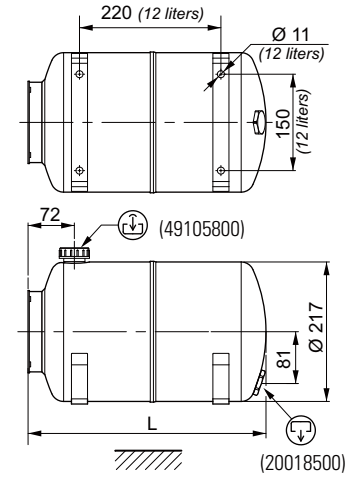

Other variants

(..) spare parts

(20018500)

Variant	Tank	Variant	Tank	Variant	Tank	Variant	Tank

* ** * (V) ** * - Tanks Ø 217 - Sheet steel, capacity 10-12 liters - Vertical mounting (black painted)

Capacity	Features	Mounting	Variant (1)	L (mm)	Capacity (liters)			Tank (with plugs)	Tank fixing kit (screws and O-Ring)
					Nominal	Full	Usable		
10	D (V) 00			273	10	7	6.8	90310029	17010080
12				370	12	10.3	10.1	90310100	

(1) Variant - OMIT if without tank but with tubes kit

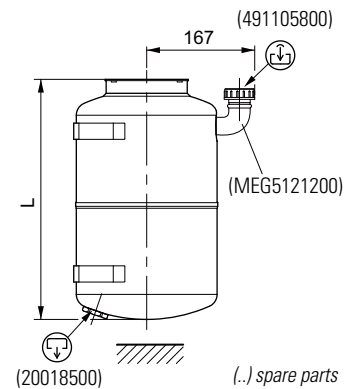

(20018500)

(..) spare parts

Other variants

Variant	Tank	Variant	Tank	Variant	Tank	Variant	Tank

Sect. IV - Tanks / Sect. V - Tubes kit



* ** * (V) ** * - Rectangular tanks - Sheet steel, capacity 7 liters - Vertical mounting (black painted)

Capacity	Features	Mounting	Variant (1)	L (mm)	Capacity (liters)			Tank (with plugs)	Tank fixing kit (screws and O-Ring)
					Nominal	Full	Usable		
07	E	(V)	00	299	7	5.5	5.1	90310014	17010080

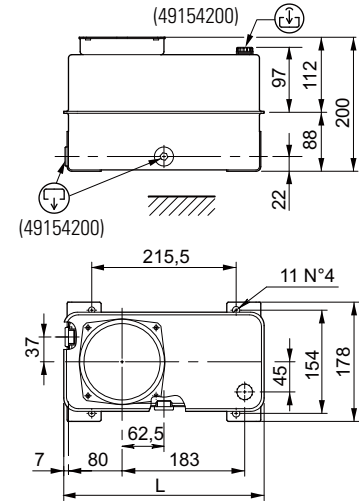

(1) Variant - OMIT if without tank but with tubes kit

(..) spare parts

Other variants

Variant				Tank				Variant				Tank				Variant				Tank			
07	E	(V)	01	90310036																			

IV
V

Sect. IV - Tanks / Sect. V - Tubes kit



* ** * (H) ** * - Rectangular tanks - Sheet steel, capacity 9 liters - Horizontal mounting (black painted)

Capacity	Features	Mounting	Variant (1)	L (mm)	Capacity (liters)			Tank (with plugs)	Tank fixing kit (screws and O-Ring)
					Nominal	Full	Usable		
09	E	(H)	00	350	9	9	8	90310142	17010080

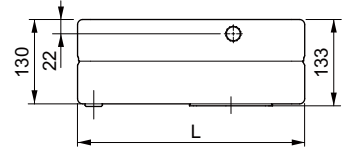
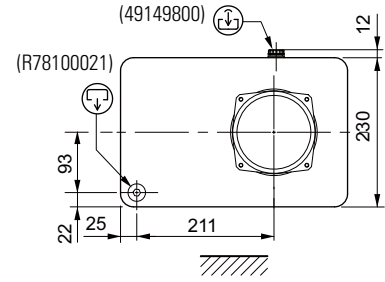

(1) Variant - OMIT if without tank but with tubes kit

(..) spare parts

Other variants

Variant	Tank	Variant	Tank	Variant	Tank	Variant	Tank

* ** * (V) ** * - Rectangular tanks - Sheet steel, capacity 9 liters - Vertical mounting (black painted)

Capacity	Features	Mounting	Variant (1)	L (mm)	Capacity (liters)			Tank (with plugs)	Tank fixing kit (screws and O-Ring)
					Nominal	Full	Usable		
09	E	(V)	00	350	9	8.6	7.5	90310142	17010080

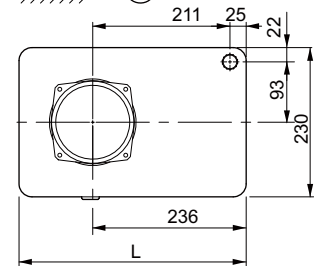
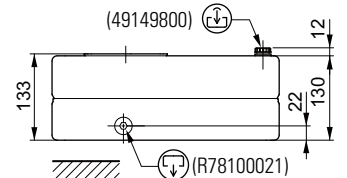

(1) Variant - OMIT if without tank but with tubes kit

(..) spare parts

Other variants

Variant	Tank	Variant	Tank	Variant	Tank	Variant	Tank

IV
V

Sect. IV - Tanks / Sect. V - Tubes kit



* ** * (*) ** * - Rectangular tanks - Sheet steel, capacity 14 liters - Vertical mounting (black painted)

Capacity	Features	Mounting	Variant (1)	L (mm)	Capacity (liters)			Tank (with plugs)	Tank fixing kit (screws and O-Ring)
					Nominal	Full	Usable		
14	E	(V)	00	366	14	14	13	90310045	17010080

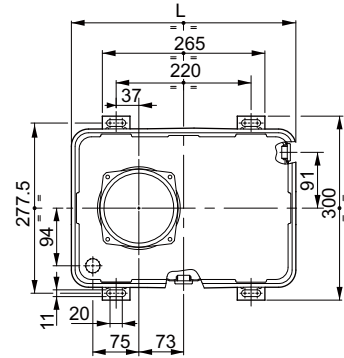
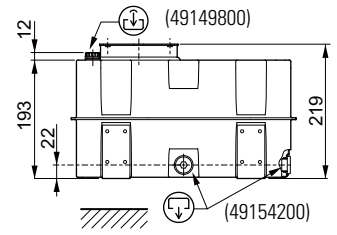

(1) Variant - OMIT if without tank but with tubes kit

(..) spare parts

Other variants

Variant				Tank				Variant				Tank			
14	E	(V)	01	90310046											

IV
V

Sect. IV - Tanks / Sect. V - Tubes kit



* ** * (*) ** * - **Rectangular tanks - Sheet steel, capacity 25 liters - Horizontal mounting (black painted)**

Capacity	Features	Mounting	Variant (1)	L (mm)	Capacity (liters)			Tank (with plugs)	Tank fixing kit (screws and O-Ring)
					Nominal	Full	Usable		
25	E	(H)	00	436	25	22	21	90310060	17010080

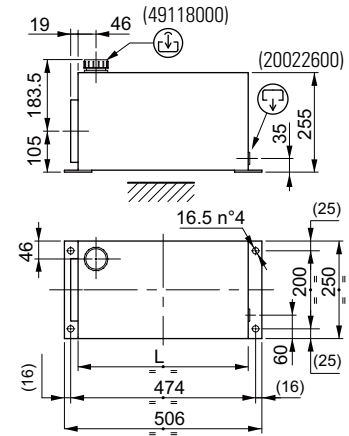

(1) Variant - OMIT if without tank but with tubes kit

(..) spare parts

Other variants

Variant	Tank	Variant	Tank	Variant	Tank	Variant	Tank
25 E (H) 01	90310083						

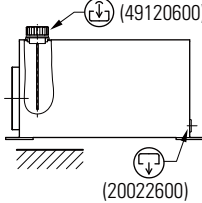

* ** * (*) ** * - **Rectangular tanks - Sheet steel, capacity 25 liters - Vertical mounting (black painted)**

Capacity	Features	Mounting	Variant (1)	L (mm)	Capacity (liters)			Tank (with plugs)	Tank fixing kit (screws and O-Ring)
					Nominal	Full	Usable		
25	E	(V)	00	436	25	25	22	90310071	17010080

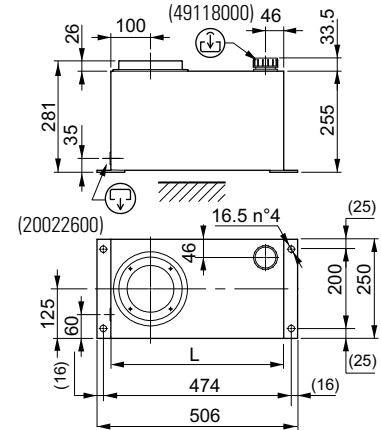

(1) Variant - OMIT if without tank but with tubes kit

(..) spare parts

Other variants

Variant	Tank	Variant	Tank	Variant	Tank	Variant	Tank
25 E (V) 01	90310124						

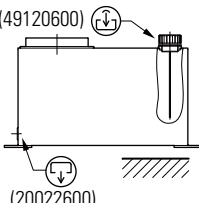

**IV
V**

Sect. IV - Tanks / Sect. V - Tubes kit



* ** * (H) ** * - **Square polypropylene tanks capacity 5-7 liters - Horizontal mounting**

Capacity	Features	Mounting	Variant (1)	L (mm)	Capacity (liters)			Tank (with plug, brackets, nuts)	Tank fixing kit (screws and O-Ring)
					Nominal	Full	Usable		
05	F	(H)	00	242	5	5.4	4.5	90310313	17010083
07				308	7	7.4	6.5	90310289	

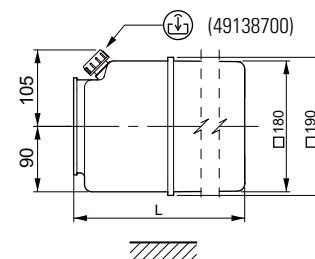

Operating temperature -10°C ÷ +60°C - (1) Variant - OMIT if without tank but with tubes kit

(..) spare parts

* ** * (V) ** * - **Square polypropylene tanks capacity 5-7 liters - Vertical mounting**

Capacity	Features	Mounting	Variant (1)	L (mm)	Capacity (liters)			Tank (with plug, brackets, nuts)	Tank fixing kit (screws and O-Ring)
					Nominal	Full	Usable		
05	F	(V)	00	242	5	5.4	4.5	90310313	17010083
07				306	7	7.4	6.5	90310289	

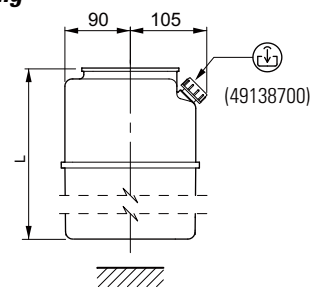

Operating temperature -10°C ÷ +60°C - (1) Variant - OMIT if without tank but with tubes kit

(..) spare parts

Sect. IV - Tanks / Sect. V - Tubes kit



*** ** * (H) ** *** - **Square polyethylene tanks capacity 1.5-2.5-4 liters - Horizontal mounting**

Capacity	Features	Mounting	Variant (1)	L (mm)	Capacity (liters)			Tank (with plugs, clamp, nuts)	Tank fixing kit collar Ø123 (screws and O-Ring)
					Nominal	Full	Usable		
02				135	1.5	1.3	1	90310491	17010081
03	G	(H)	00	235	2.5	2.5	2	90310484	
04				295	4	3.4	2.5	90310422	

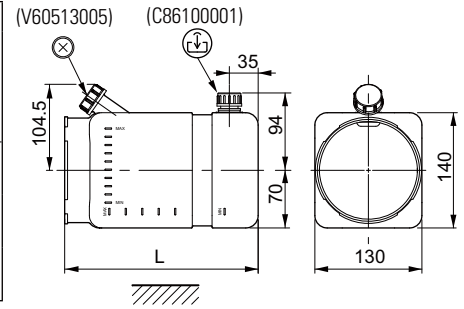

Operating temperature -10°C ÷ +70°C - (1) Variant - OMIT if without tank but with tubes kit

(..) spare parts

Other variants

Variant	Tank	Variant	Tank	Variant	Tank	Variant	Tank

*** ** * (V) ** *** - **Square polyethylene tanks capacity 1.5-2.5-4 liters - Vertical mounting**

Capacity	Features	Mounting	Variant (1)	L (mm)	Capacity (liters)			Tank (with plugs, clamp, nuts)	Tank fixing kit collar Ø123 (screws and O-Ring)
					Nominal	Full	Usable		
02				135	1.5	1.1	0.7	90310486	17010081
03	G	(V)	00	235	2.5	2.7	2.3	90310419	
04				296	4	3.5	3.1	90310402	

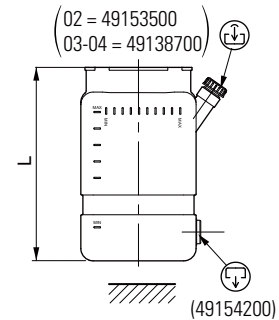

Operating temperature -10°C ÷ +70°C - (1) Variant - OMIT if without tank but with tubes kit

(..) spare parts

Other variants

Variant	Tank	Variant	Tank	Variant	Tank	Variant	Tank

**IV
V**

Sect. IV - Tanks / Sect. V - Tubes kit



*** ** * (*) ** *** - **Square polyethylene tanks capacity 7-10 liters - Horizontal mounting**

Capacity	Features	Mounting	Variant (1)	L (mm)	Capacity (liters)			Tank (with plugs, clamp, nuts)	Tank fixing kit collar Ø123 (screws and O-Ring)
					Nominal	Full	Usable		
07	L (H) 00			310	7	6.7	5.5	90310330	17010081
10				410	10	8.7	7.5	90310339	

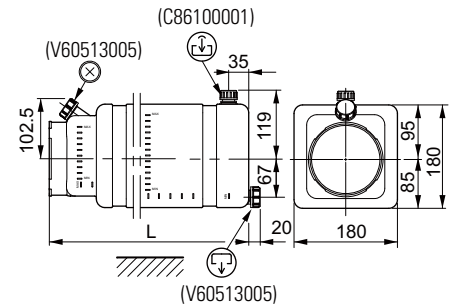

Operating temperature -10°C ÷ +70°C - (1) Variant - OMIT if without tank but with tubes kit

(..) spare parts

*** ** * (*) ** *** - **Square polyethylene tanks capacity 7-10 liters - Vertical mounting**

Capacity	Features	Mounting	Variant (1)	L (mm)	Capacity (liters)			Tank (with plugs, clamp, nuts)	Tank fixing kit collar Ø123 (screws and O-Ring)
					Nominal	Full	Usable		
07	L (V) 00			310	7	6.7	6	90310403	17010081
10				410	10	9.8	9	90310338	

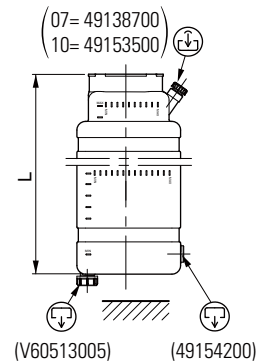

Operating temperature -10°C ÷ +70°C - (1) Variant - OMIT if without tank but with tubes kit

(..) spare parts

*** ** * (*) ** *** - **Square polyethylene tanks capacity 9 liters - Vertical mounting**

Capacity	Features	Mounting	Variant (1)	L (mm)	Capacity (liters)			Tank (with plugs, clamp, nuts)	Tank fixing kit collar Ø123 (screws and O-Ring)
					Nominal	Full	Usable		
09	L (V) 00			370	9	8.6	8	90310371	17010081

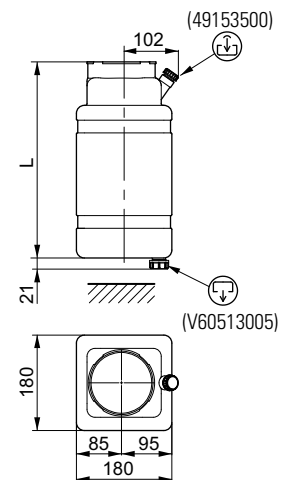

Operating temperature -10°C ÷ +70°C - (1) Variant - OMIT if without tank but with tubes kit

(..) spare parts

**IV
V**

Sect. IV - Tanks / Sect. V - Tubes kit



*** ** * (H) ** *** - *Special square polyethylene tanks capacity 7 liters - Horizontal mounting*

Capacity	Features	Mounting	Variant (1)	L (mm)	Capacity (liters)			Tank (with plugs, clamp, nuts)	Tank fixing kit collar Ø123 (screws and O-Ring)
					Nominal	Full	Usable		
07	M	(H)	00	335	7	7.3	6.6	90310380	17010081

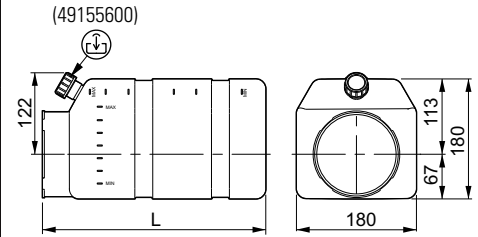

Operating temperature -10°C ÷ +70°C - (1) Variant - OMIT if without tank but with tubes kit

(..) spare parts

Other variants

Variant	Tank	Variant	Tank	Variant	Tank	Variant	Tank

*** ** * (V) ** *** - *Special square polyethylene tanks capacity 7 liters - Vertical mounting*

Capacity	Features	Mounting	Variant (1)	L (mm)	Capacity (liters)			Tank (with plugs, clamp, nuts)	Tank fixing kit collar Ø123 (screws and O-Ring)
					Nominal	Full	Usable		
07	M	(V)	00	335	7	7.2	6.4	90310380	17010081

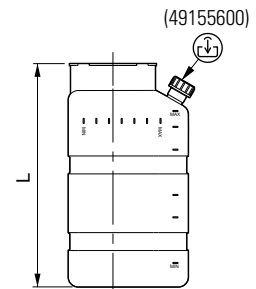

Operating temperature -10°C ÷ +70°C - (1) Variant - OMIT if without tank but with tubes kit

(..) spare parts

Other variants

Variant	Tank	Variant	Tank	Variant	Tank	Variant	Tank

IV
V

Sect. IV - Tanks / Sect. V - Tubes kit



* ** * (*) ** /* - Tanks orientation according to the mounting position

For tanks			(*)	Mounting position	/* Orientation			
S	**	A B C D			/1 (standard)	/2	/3	/4
Horizontal			(H)		 (1)			

For tanks			(*)	Mounting position	/* Orientation			
S	09	E			/1 (standard)			
Horizontal			(H)					

For tanks			(*)	Mounting position	/* Orientation			
S	25	E			/1 (standard)			
Horizontal			(H)					

For tanks			(*)	Mounting position	/* Orientation			
S	**	F G L			/1 (standard)	/2	/3	/4
Horizontal			(H)		 (1)			

(1) Orientation TO BE USED with blocks

IV
V

Sect. IV - Tanks / Sect. V - Tubes kit



* ** * (*) ** /* - Tanks orientation according to the mounting position

For tanks			(*)	Mounting position	/* Orientation			
			(V)	Vertical	/1 (standard)	/2	/3	/4
S	**	A B C D F G L	(V)		 (2)			

For tanks			(*)	Mounting position	/* Orientation			
			(V)	Vertical	/1 (standard)	/2	/3	/4
S	07	E	(V)		 (1)			

For tanks			(*)	Mounting position	/* Orientation			
			(V)	Vertical	/1 (standard)	/2	/3	/4
S	09 25	E	(V)		 (1)			

For tanks			(*)	Mounting position	/* Orientation			
			(V)	Vertical	/1 (standard)	/2	/3	/4
S	14	E	(V)		 (1)			

(1) Orientation TO BE USED with blocks
 (2) D Orientation DO NOT USE with blocks

IV
V

Sect. VI - DC Motors

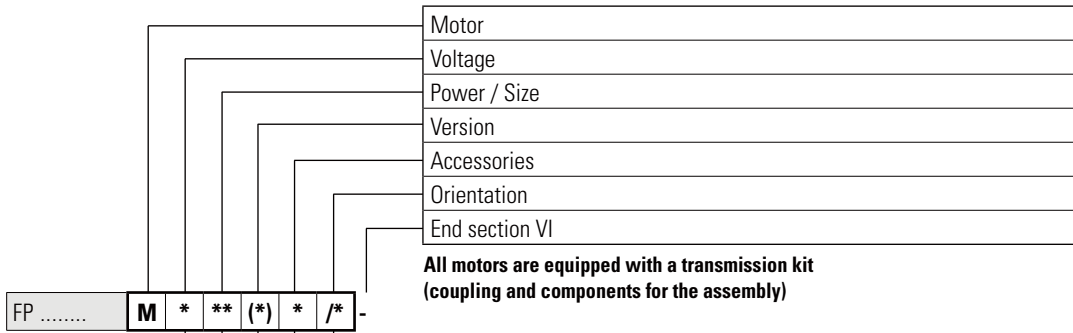

All motors are equipped with a transmission kit (coupling and components for the assembly)

* Voltage	** Power	Size	(*) Version	Page	* Accessories	/ * Orientation	Page	
2 12 VDC	GA	350 W	Ø 80	(1) Std	72	0 - B	/1 /2 Std /3 /4	76
	GC	700 W	Ø 80	(1) Std	72	0 - B		
	AA	1500 W	Ø 115	(1) Std	73	0 - B - C - D - F - G - H		
	EN	1600 W	Ø 115	(1) Std	73	0 - B - C - E		
	GN	1600 W	Ø 115	(1) Std	74	0 - B - C - E		
4 24 VDC	GB	400 W	Ø 80	(1) Std	72	0 - B		
	GD	800 W	Ø 80	(1) Std	72	0 - B		
	AB	2000 W	Ø 115	(1) Std	73	0 - B - C - D - F - G - H		
	ES	2200 W	Ø 115	(1) Std	73	0 - B - C - E		
	GP	2200 W	Ø 115	(1) Std	74	0 - B - C - E		
	GJ	3000 W	Ø 125	(1) Std	74	0 - B - C - E		
	FB	3000 W	Ø 125	(1) Std	74	0 - B - C - E		

* Accessories description	Page
0 Without accessories	—
B Starting switch	75
C Thermal protection	—
D (•) Ventilation	75
E Starting switch + thermal protection	—
F (•) Starting switch + ventilation	—
G Thermal protection + ventilation	—
H (•) Starting switch + thermal protection + ventilation	—

(•)= IP protection level becomes effective after installation on power pack. Acquires IP 10 level with "ventilation" accessory.

VI
DC

For more details, features and performances DC motors, see catalog Dana code DOC00053.

Sect. VI - DC Motors



Motors: 12 VDC 350 W / 24 VDC 400 W (permanent magnets)

	Voltage	W	A	rpm	Nm	S2 min	S3%	IP	IC	Ø mm	Code (⊗)
M 2 GA (1) * /*	12 VDC	350	40	3300	1.0	10	35	54	F	80	25021400
M 4 GB (1) * /*	24 VDC	400	30	3100	1.2	5	20	54	F	80	25021500

IP protection level becomes effective after installation on power pack.
 (⊗) Motor without accessories

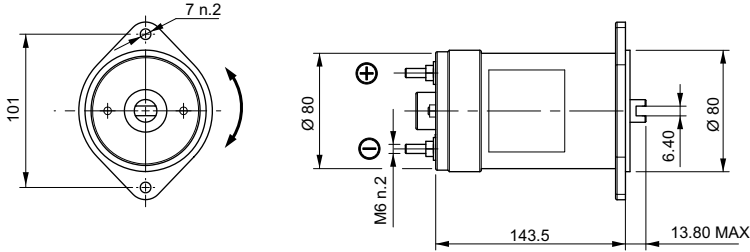

M * ** (*) * /* - Accessories (page 75)

* Description
0 Without accessories
B Starting switch 120A fixing with clamp

Code trasmission kit: page 83

Motors: 12 VDC 700 W / 24 VDC 800 W (permanent magnets)

	Voltage	W	A	rpm	Nm	S2 min	S3%	IP	IC	Ø mm	Code (⊗)
M 2 GC (1) * /*	12 VDC	700	90	3300	2.0	2.5	10	54	F	80	25021600
M 4 GD (1) * /*	24 VDC	800	70	3000	2.5	2	5	54	F	80	25021700

IP protection level becomes effective after installation on power pack.
 (⊗) Motor without accessories

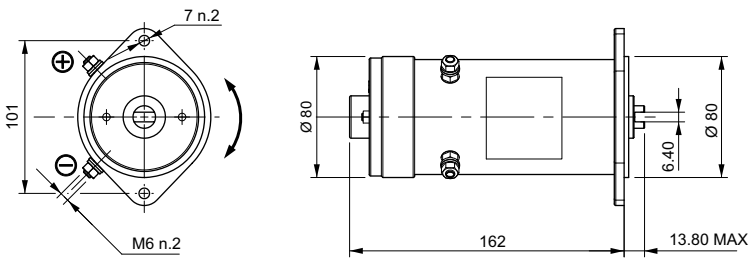

M * ** (*) * /* - Accessories (page 75)

* Description
0 Without accessories
B Starting switch 120A

Code trasmission kit: page 83

For more details, features and performances DC motors, see catalog Dana code DOC00053.

Sect. VI - DC Motors



Motors: 12 VDC 1500 W / 24 VDC 2000 W (wound field compound)

	Voltage	W	A	rpm	Nm	S2 min	S3%	IP	IC	Ø mm	Code (⊗)
M 2 AA (1) * /*	12 VDC	1500	225	2500	5.5	1	5	54	F	115	25022200
M 4 AB (1) * /*	24 VDC	2000	150	2250	8	2	5	54	F	115	25022300

IP protection level becomes effective after installation on power pack.

(⊗) Motor without accessories

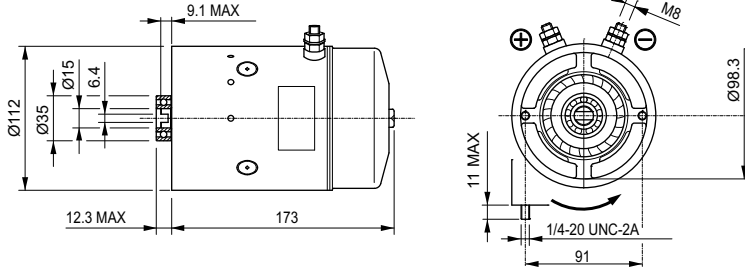

Code transmission kit: page 83

M * ** (*) * /* - Accessories (page 75)

* Description
0 Without accessories
B Starting switch 120A
D Ventilation
F Ventilation + Starting switch
G Ventilation + Thermal protection
H Ventilation + Thermal protection + Starting switch

Acquires IP 10 protection level with "ventilation" accessory.

Motors: 12 VDC 1600 W / 24 VDC 2200 W (wound field compound)

	Voltage	W	A	rpm	Nm	S2 min	S3%	IP	IC	Ø mm	Code (⊗)
M 2 EN (1) * /*	12 VDC	1600	230	2600	5	2	10	54	F	115	25021100
M 4 ES (1) * /*	24 VDC	2200	140	2700	8	1.2	5	54	F	115	25021200

IP protection level becomes effective after installation on power pack.

() Motor without accessories

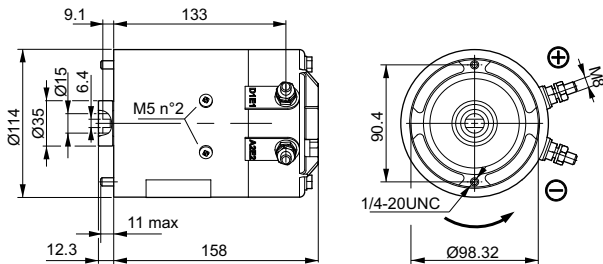

Code transmission kit: page 83

M * ** (*) * /* - Accessories (page 75)

* Description
0 Without accessories
B Starting switch 120A
C Thermal protection
E Starting switch + thermal protection

For more details, features and performances DC motors, see catalog Dana code DOC00053.

Sect. VI - DC Motors



Motors: 12 VDC 1600 W / 24 VDC 2200 W (wound field serie)

	Voltage	W	A	rpm	Nm	S2 min	S3%	IP	IC	Ø mm	Code (⊗)
M 2 GN (1) * /*	12 VDC	1600	220	2600	6	4	8	54	F	115	25022600
M 4 GP (1) * /*	24 VDC	2200	140	2600	6	2	7.5	54	F	115	25022700

IP protection level becomes effective after installation on power pack.
 (⊗) Motor without accessories

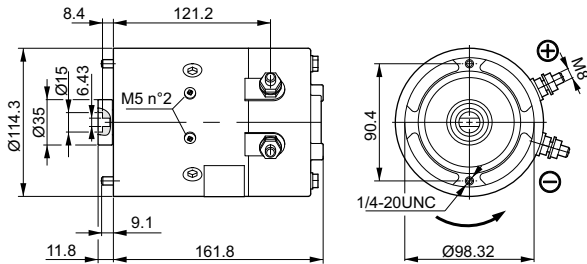

M * ** (*) * /* - Accessories (page 75)

* Description
0 Without accessories
B Starting switch 120A
Code trasmission kit: page 83

Motors: 24 VDC 3000 W (wound field compound)

	Voltage	W	A	rpm	Nm	S2 min	S3%	IP	IC	Ø mm	Code (⊗)
M 4 FB (1) * /*	24 VDC	3000	200	3300	8.5	4	15	20	F	125	25021300
M 4 GJ (1) * /*	24 VDC	3000	180	3500	8.5	3.5	15	20	F	125	25022400

IP protection level becomes effective after installation on power pack.
 (⊗) Motor without accessories

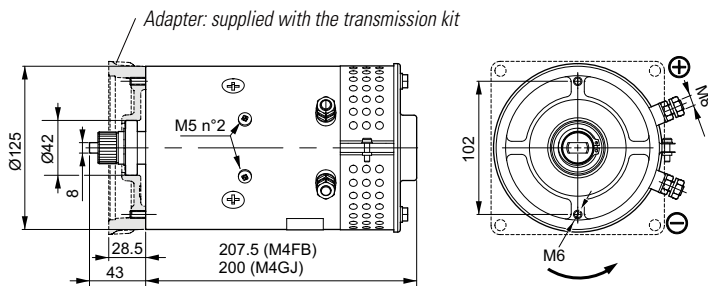

M * ** (*) * /* - Accessories (page 75)

** * Description
0 Without accessories
B Starting switch 150A
D Ventilation
F Ventilation + Starting switch
G Ventilation + Thermal protection
H Ventilation + Thermal protection + Starting switch
Code trasmission kit: page 83

For more details, features and performances DC motors, see catalog Dana code DOC00053.

Sect. VI - DC Motors



M * ** (*) **C** /* - **Accessory: Thermal protection**

Thermal protection		
Code	Ø mm	For motors
90340009	16	M2EN - M4ES

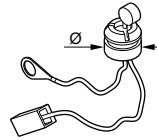

M * ** (*) **B** /* - **Accessory: Starting switch**

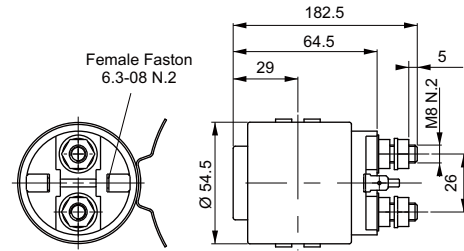
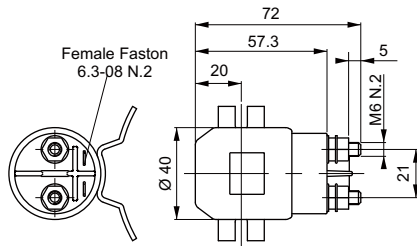

120A starting switch		
Code (•)	VDC	For motors
KIT07012.027	12	M2GA - M2GC
KIT07012.032	24	M4GB - M4GD
KIT07012.033	12	M2AA
KIT07012.034	24	M4AB
KIT07012.025	12	M2EN - M2GN
KIT07012.026	24	M4ES - M2GP

150A starting switch		
Code (•)	VDC	For motors
KIT07012.019	24	M4FB - M4GJ

(•) Complete kit with all assembly components.

For more details, features and performances DC motors, see catalog Dana code DOC00053.

M * ** (*) ***** /* - **Accessory: Ventilation (motor included)**

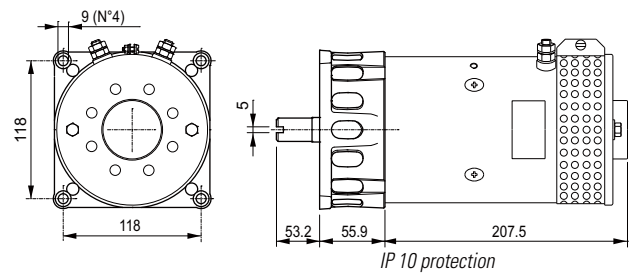
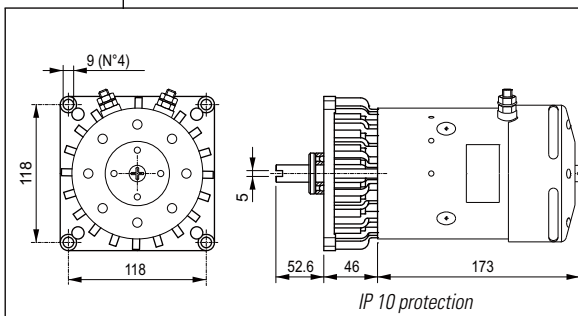

VI
DC

*	Code (•)	VDC	For motors
D	KIT09008.061	12	M2AA
G	KIT09008.062	12	M2AA + thermal protection
D	KIT09008.031	24	M4AB
G	KIT09008.063	24	M4AB + thermal protection

*	Code (•)	VDC	For motors
D	KIT09008.029	24	M4FB

(•) Complete kit with all assembly components (motor, transmission kit, etc).

For more details, features and performances DC motors, see catalog Dana code DOC00053.

M * ** (*) * /* - Motor orientation

Starting switch and poles position.

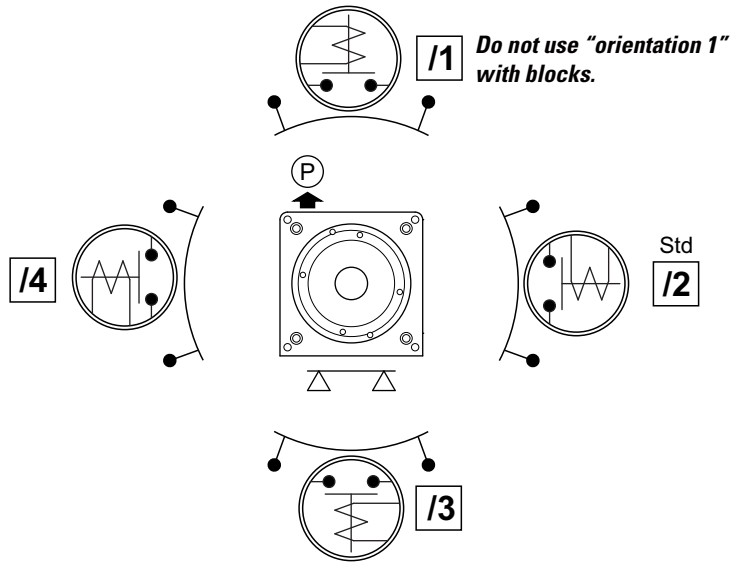
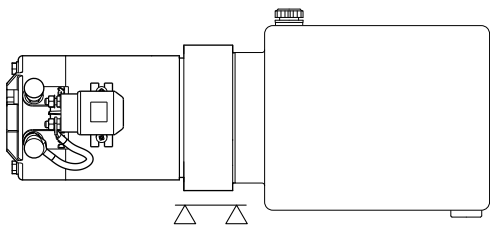

Sect. VI - AC Motors

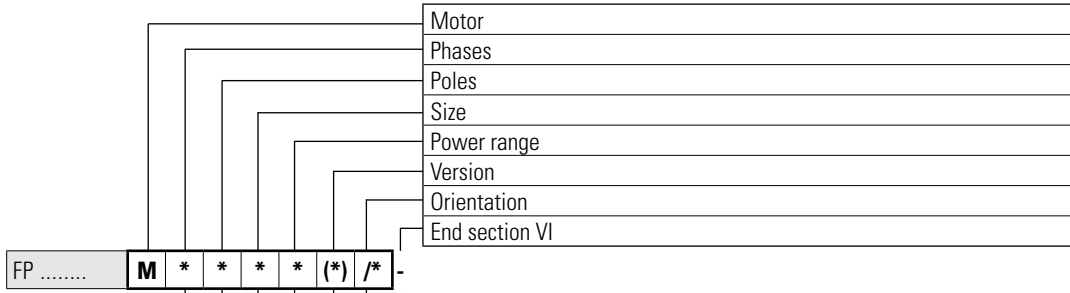

*	Phases	* Poles	*	Size	* Power range		Page	(*) Version	/* Orientation	Page	
					Power	Voltage					
M	Single phase	2	L	71	A	0.37 kW	230 Vac 50 Hz	78	(1) Std	/1 /2 /3 /4 Std	82
			L	71	B	0.55 kW	230 Vac 50 Hz	78			
			S	71	A	0.75 kW	230 Vac 50 Hz	80			
			S	71	B	1.10 kW	230 Vac 50 Hz	80			
			M	80	A	0.75 kW	230 Vac 50 Hz	78			
			M	80	B	1.10 kW	230 Vac 50 Hz	78			
			N	90	A	1.50 kW	230 Vac 50 Hz	78			
			N	90	B	2.20 kW	230 Vac 50 Hz	78			
			P	100	A	3.00 kW	230 Vac 50 Hz	78			
			L	71	A	0.25 kW	230 Vac 50 Hz	78			
		L	71	B	0.37 kW	230 Vac 50 Hz	78				
		S	71	C	0.85 kW	230 Vac 50 Hz	80				
		M	80	A	0.55 kW	230 Vac 50 Hz	78				
		M	80	B	0.75 kW	230 Vac 50 Hz	78				
		N	90	A	1.10 kW	230 Vac 50 Hz	78				
		N	90	B	1.50 kW	230 Vac 50 Hz	78				
		V	90	A	1.80 kW	230 Vac 50 Hz	81				
		V	90	B	3.00 kW	230 Vac 50 Hz	81				
		P	100	A	2.20 kW	230 Vac 50 Hz	78				
		T	Three phase	2	R	63	A	0.18 kW			
R	63				B	0.25 kW	230/400 Vac 50 Hz	79			
L	71				A	0.37 kW	230/400 Vac 50 Hz	79			
L	71				B	0.55 kW	230/400 Vac 50 Hz	79			
S	71				A	0.75 kW	230/400 Vac 50 Hz	80			
S	71				B	1.10 kW	230/400 Vac 50 Hz	80			
M	80				A	0.75 kW	230/400 Vac 50 Hz	79			
M	80				B	1.10 kW	230/400 Vac 50 Hz	79			
T	80				A	2.70 kW	230/400 Vac 50 Hz	81			
T	80				B	2.70 kW	230/400 Vac 50 Hz	81			
N	90				A	1.50 kW	230/400 Vac 50 Hz	79			
N	90				B	2.20 kW	230/400 Vac 50 Hz	79			
P	100				A	3.00 kW	230/400 Vac 50 Hz	79			
P	112				B	4.00 kW	230/400 Vac 50 Hz	79			
R	63			A	0.12 kW	230/400 Vac 50 Hz	79				
R	63			B	0.18 kW	230/400 Vac 50 Hz	79				
L	71			A	0.25 kW	230/400 Vac 50 Hz	79				
L	71			B	0.37 kW	230/400 Vac 50 Hz	79				
S	71			A	0.75 kW	230/400 Vac 50 Hz	80				
M	80			A	0.55 kW	230/400 Vac 50 Hz	79				
M	80			B	0.75 kW	230/400 Vac 50 Hz	79				
T	80			A	2.20 kW	230/400 Vac 50 Hz	81				
T	80			B	2.20 kW	230/400 Vac 50 Hz	81				
T	80			C	2.20 kW	230/400 Vac 50 Hz	81				
T	80			D	3.00 kW	230/400 Vac 50 Hz	81				
N	90			A	1.10 kW	230/400 Vac 50 Hz	79				
N	90			B	1.50 kW	230/400 Vac 50 Hz	79				
P	100			A	2.20 kW	230/400 Vac 50 Hz	79				
P	100	B	3.00 kW	230/400 Vac 50 Hz	79						
P	112	C	4.00 kW	230/400 Vac 50 Hz	79						

Motors supplied with all assembly components (transmission kit, coupling, etc).

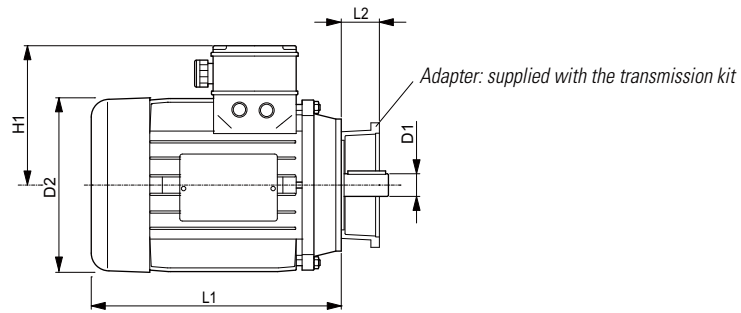

Single-phase motors 2-4 Poles - 230 Vac 50Hz - Version B14

M	M	Poles	Size	D1 (•)	D2 (•)	H1 (•)	L1 (•)	Power range					Cable gland metric thread	Adapter			Single Motor	Transmission kit (for pump)					
								Power kW	Voltage	IP	IC	S1		Code	Screw UNI 5931	L2							
M	M	2	L	A	(1)	2	2	71	14	148	115	208	0.37	230 Vac 50 Hz	54	F	Si	20-25	61000700	M6x20	19.5	M12E2000	KIT08019.011 (Gr.05)
M	M	2	L	B	(1)	2	2	71	14	148	115	208	0.55	230 Vac 50 Hz	54	F	Si	20-25	61000700	M6x20	19.5	M12F2000	KIT08019.012 (Gr.1)
M	M	2	M	A	(1)	2	2	80	19	170	126	234	0.75	230 Vac 50 Hz	54	F	Si	20-25	61000800	M6x20	30.4	M13G2000	KIT08019.013 (Gr.05)
M	M	2	M	B	(1)	2	2	80	19	170	126	234	1.10	230 Vac 50 Hz	54	F	Si	20-25	61000800	M6x20	30.4	M13H2000	KIT08019.014 (Gr.1)
M	M	2	N	A	(1)	2	2	90	24	185	142	247	1.50	230 Vac 50 Hz	54	F	Si	20-25	61000900	M8x21	40.4	M14L2000	KIT08019.015 (Gr.05)
M	M	2	N	B	(1)	2	2	90	24	185	142	272	2.20	230 Vac 50 Hz	54	F	Si	20-25	61000900	M8x21	40.4	M14N2000	KIT08019.016 (Gr.1)
M	M	2	P	A	(1)	2	2	100	28	210	155	310	3.00	230 Vac 50 Hz	54	F	Si	25-32	61001000	M8x28	75	M15P2000	KIT08019.017 (Gr.05)
																							KIT08019.018 (Gr.1)
M	M	4	L	A	(1)	2	4	71	14	148	115	208	0.25	230 Vac 50 Hz	54	F	Si	20-25	61000700	M6x20	19.5	M12D4000	KIT08019.011 (Gr.05)
M	M	4	L	B	(1)	2	4	71	14	148	115	208	0.37	230 Vac 50 Hz	54	F	Si	20-25	61000700	M6x20	19.5	M12E4000	KIT08019.012 (Gr.1)
M	M	4	M	A	(1)	2	4	80	19	170	126	234	0.55	230 Vac 50 Hz	54	F	Si	20-25	61000800	M6x20	30.4	M13F4000	KIT08019.013 (Gr.05)
M	M	4	M	B	(1)	2	4	80	19	170	126	234	0.75	230 Vac 50 Hz	54	F	Si	20-25	61000800	M6x20	30.4	M13G4000	KIT08019.014 (Gr.1)
M	M	4	N	A	(1)	2	4	90	24	185	142	247	1.10	230 Vac 50 Hz	54	F	Si	20-25	61000900	M8x21	40.4	M14H4000	KIT08019.015 (Gr.05)
M	M	4	N	B	(1)	2	4	90	24	185	142	272	1.50	230 Vac 50 Hz	54	F	Si	20-25	61000900	M8x21	40.4	M14L4000	KIT08019.016 (Gr.1)
M	M	4	P	A	(1)	2	4	100	28	210	155	310	2.20	230 Vac 50 Hz	54	F	Si	25-32	61001000	M8x28	75	M15N4000	KIT08019.017 (Gr.05)
																							KIT08019.018 (Gr.1)

(•)= Approximate dimensions

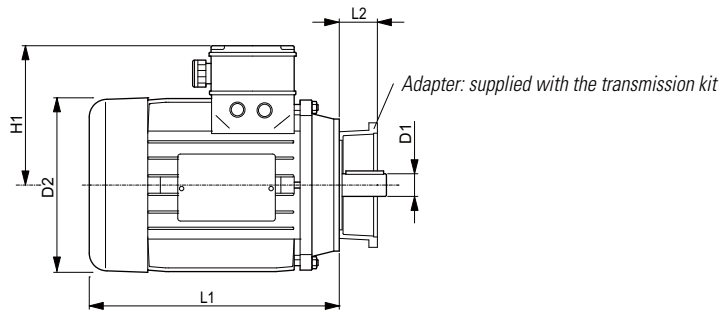

Three-phase motors 2-4 Poles - 230/400 Vac 50Hz - Version B14

M	T	Poles	Size	D1 (*)	D2 (*)	H1 (*)	L1 (*)	Power range					Cable gland metric thread	Adapter			Single Motor	Transmission kit (for pump)					
								Power kW	Voltage	IP	IC	S3		Code	Screw UNI 5931	L2							
M	T	2	R	A	(1)	3	2	63	11	125	95	189	0.18	230/400 Vac 50 Hz	54	F	60%	16-20	61004300	M5x16	19.5	M31C2000	KIT08019.009 (Gr.05)
M	T	2	R	B	(1)	3	2	63	11	125	95	189	0.25	230/400 Vac 50 Hz	54	F	60%	16-20	61004300	M5x16	19.5	M31D2000	KIT08019.010 (Gr.1)
M	T	2	L	A	(1)	3	2	71	14	148	115	208	0.37	230/400 Vac 50 Hz	54	F	60%	20-25	61000700	M6x20	19.5	M32E2000	KIT08019.011 (Gr.05)
M	T	2	L	B	(1)	3	2	71	14	148	115	208	0.55	230/400 Vac 50 Hz	54	F	60%	20-25	61000700	M6x20	19.5	M32F2000	KIT08019.012 (Gr.1)
M	T	2	M	A	(1)	3	2	80	19	170	126	234	0.75	230/400 Vac 50 Hz	54	F	60%	20-25	61000800	M6x20	30.4	M33G2000	KIT08019.013 (Gr.05)
M	T	2	M	B	(1)	3	2	80	19	170	126	234	1.10	230/400 Vac 50 Hz	54	F	60%	20-25	61000800	M6x20	30.4	M33H2000	KIT08019.014 (Gr.1)
M	T	2	N	A	(1)	3	2	90	24	185	142	247	1.50	230/400 Vac 50 Hz	54	F	60%	20-25	61000900	M8x21	40.4	M34L2000	KIT08019.015 (Gr.05)
M	T	2	N	B	(1)	3	2	90	24	185	142	272	2.20	230/400 Vac 50 Hz	54	F	60%	20-25	61000900	M8x21	40.4	M34N2000	KIT08019.016 (Gr.1)
M	T	2	P	A	(1)	3	2	100	28	210	155	310	3.00	230/400 Vac 50 Hz	54	F	60%	25-32	61001000	M8x28	75	M35P2000	KIT08019.017 (Gr.05)
M	T	2	P	B	(1)	3	2	112	28	225	182	325	4.00	230/400 Vac 50 Hz	54	F	60%	25-32	61001000	M8x28	75	M36Q2000	KIT08019.018 (Gr.1)
M	T	4	R	A	(1)	3	4	63	11	125	95	189	0.12	230/400 Vac 50 Hz	54	F	60%	16-20	61004300	M5x16	19.5	M31B4000	KIT08019.009 (Gr.05)
M	T	4	R	B	(1)	3	4	63	11	125	95	189	0.18	230/400 Vac 50 Hz	54	F	60%	16-20	61004300	M5x16	19.5	M31C4000	KIT08019.010 (Gr.1)
M	T	4	L	A	(1)	3	4	71	14	148	115	208	0.25	230/400 Vac 50 Hz	54	F	60%	20-25	61000700	M6x20	19.5	M32D4000	KIT08019.011 (Gr.05)
M	T	4	L	B	(1)	3	4	71	14	148	115	208	0.37	230/400 Vac 50 Hz	54	F	60%	20-25	61000700	M6x20	19.5	M32E4000	KIT08019.012 (Gr.1)
M	T	4	M	A	(1)	3	4	80	19	170	126	234	0.55	230/400 Vac 50 Hz	54	F	60%	20-25	61000800	M6x20	30.4	M33F4000	KIT08019.013 (Gr.05)
M	T	4	M	B	(1)	3	4	80	19	170	126	234	0.75	230/400 Vac 50 Hz	54	F	60%	20-25	61000800	M6x20	30.4	M33G4000	KIT08019.014 (Gr.1)
M	T	4	N	A	(1)	3	4	90	24	185	142	247	1.10	230/400 Vac 50 Hz	54	F	60%	20-25	61000900	M8x21	40.4	M34H4000	KIT08019.015 (Gr.05)
M	T	4	N	B	(1)	3	4	90	24	185	142	272	1.50	230/400 Vac 50 Hz	54	F	60%	20-25	61000900	M8x21	40.4	M34L4000	KIT08019.016 (Gr.1)
M	T	4	P	A	(1)	3	4	100	28	210	155	310	2.20	230/400 Vac 50 Hz	54	F	60%	25-32	61001000	M8x28	75	M35N4000	KIT08019.017 (Gr.05)
M	T	4	P	B	(1)	3	4	100	28	210	155	310	3.00	230/400 Vac 50 Hz	54	F	60%	25-32	61001000	M8x28	75	M35P4000	KIT08019.018 (Gr.1)
M	T	4	P	C	(1)	3	4	112	28	225	182	325	4.00	230/400 Vac 50 Hz	54	F	60%	25-32	61001000	M8x28	75	M36Q4000	

(*)= Approximate dimensions

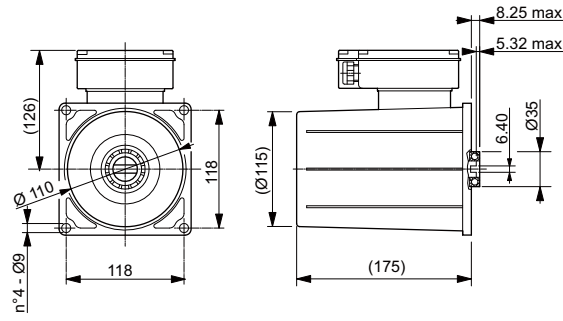

Single-phase motors 2-4 Poles - 230 Vac 50Hz - Special housing

M	M	Poles	Size	Power range				Cable gland metric thread	Single Motor	Transmission kit	Note
				Power kW	Voltage	IP	IC				
M	M	2	71	0.75	230 Vac 50 Hz	54	F	Light-duty	20	M12GY3FF.001 KIT08019.005 (for pumps Gr.1) KIT08019.006 (for pumps Gr.0.5)	Without fan
M	M	2	71	1.10	230 Vac 50 Hz	54	F	Light-duty	20	M12HY3FF.000 KIT08019.005 (for pumps Gr.1) KIT08019.006 (for pumps Gr.0.5)	Without fan
M	M	4	71	0.85	230 Vac 50 Hz	54	F	Light-duty	20	M12YY3FF.001 KIT08019.005 (for pumps Gr.1) KIT08019.006 (for pumps Gr.0.5)	Without fan

IP protection level becomes effective after installation on power pack.

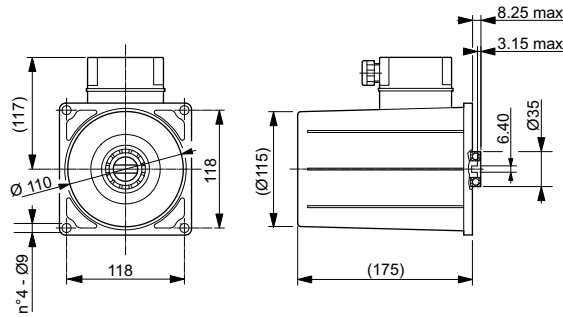

Three-phase motors 2-4 Poles - 230/400 Vac 50Hz - Direct fixing

M	T	Poles	Size	Power range				Cable gland metric thread	Single Motor	Transmission kit	Note
				Power kW	Voltage	IP	IC				
M	T	2	71	0.75	230/400 Vac 50 Hz	54	F	Light-duty	20	M32GY3FL.003 KIT08019.005 (for pumps Gr.1) KIT08019.006 (for pumps Gr.0.5)	Without fan
M	T	2	71	1.10	230/400 Vac 50 Hz	54	F	Light-duty	20	M32HY3FL.001 KIT08019.005 (for pumps Gr.1) KIT08019.006 (for pumps Gr.0.5)	Without fan
M	T	4	71	0.75	230/400 Vac 50 Hz	54	F	Light-duty	20	M32GY3FL.002 KIT08019.005 (for pumps Gr.1) KIT08019.006 (for pumps Gr.0.5)	Without fan

IP protection level becomes effective after installation on power pack.

With fan

Without fan

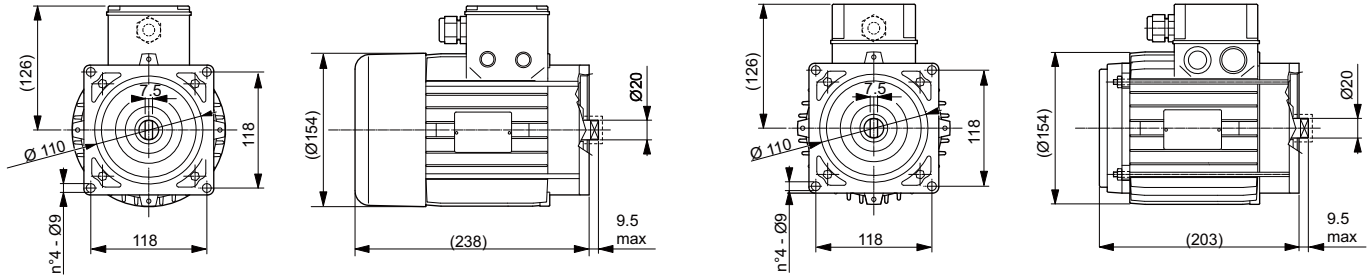

Three-phase motors 2-4 Poles - 230/400 Vac 50Hz - Direct fixing

Phases	Poles	Size	Power range					Cable gland metric, thred	Single Motor	Transmission kit	Note
			Power kW	Voltage	IP	IC	Service				
M	T 2 T A (1)	3 2 80	2.7	230/400 Vac 50 Hz	44	F	Light-duty	20-25	M33YD1FF.000	KIT08019.007 (for pumps Gr.0.5) KIT08019.008 (for pumps Gr.1)	With fan
M	T 2 T B (1)	3 2 80	2.7	230/400 Vac 50 Hz	44	F	Light-duty	20-25	M33YD1FF.001	KIT08019.007 (for pumps Gr.0.5) KIT08019.008 (for pumps Gr.1)	Without fan
M	T 4 T A (1)	3 4 80	2.2	230/400 Vac 50 Hz	44	F	S3 - 4%	20-25	M33NF1FF.001	KIT08019.007 (for pumps Gr.0.5) KIT08019.008 (for pumps Gr.1)	Without fan
M	T 4 T B (1)	3 4 80	2.2	230/400 Vac 50 Hz	55	F	S3 - 4%	20-25	M33NF4FF.000	KIT08019.007 (for pumps Gr.0.5) KIT08019.008 (for pumps Gr.1)	With fan
M	T 4 T C (1)	3 4 80	2.2	230/400 Vac 50 Hz	44	F	S3 - 4%	20-25	M33NF1FF.000	KIT08019.007 (for pumps Gr.0.5) KIT08019.008 (for pumps Gr.1)	With fan
M	T 4 T D (1)	3 4 80	3.0	230/400 Vac 50 Hz	54	F	Light-duty	20-25	M33PF3FF.000	KIT08019.007 (for pumps Gr.0.5) KIT08019.008 (for pumps Gr.1)	With fan

IP protection level becomes effective after installation on power pack.

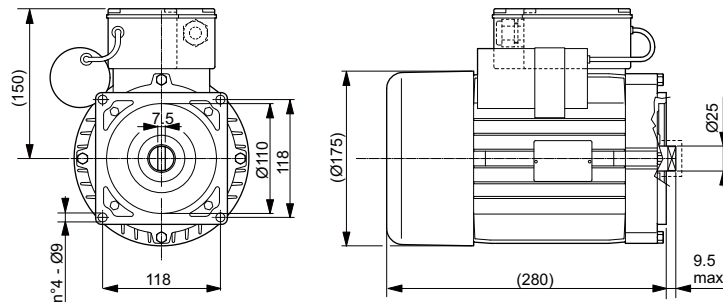

Single-phase motors 4 Poles - 230 Vac 50Hz - Direct fixing

Phases	Poles	Size	Power range					Cable gland metric, thred	Single Motor	Transmission kit	Note
			Power kW	Voltage	IP	IC	Service				
M	M 4 V A (1)	2 4 90	1.8	230 Vac 50 Hz	44	F	Light-duty	20-25	M14MF1FF.001	KIT08019.007 (for pumps Gr.0.5) KIT08019.008 (for pumps Gr.1)	With fan Start torque 13Nm
M	M 4 V B (1)	2 4 90	3.0	230 Vac 50 Hz	55	F	S3 - 7%	20-25	M14PF4FF.000	KIT08019.007 (for pumps Gr.0.5) KIT08019.008 (for pumps Gr.1)	With fan

IP protection level becomes effective after installation on power pack.

Sect. VI - AC Motors



M * * * * (*) / * - Motor orientation

Connector box position on power pack.

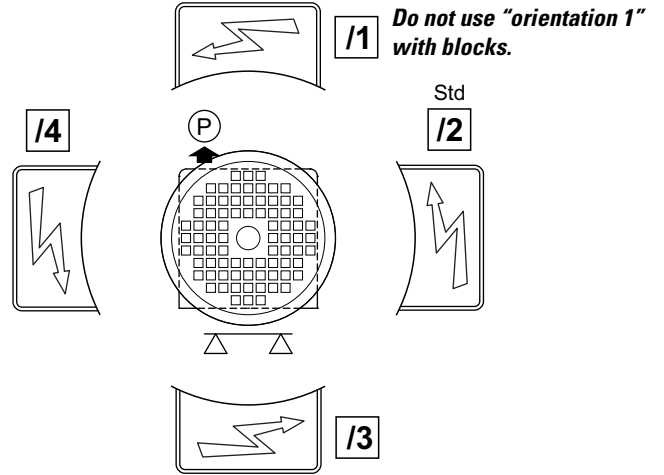
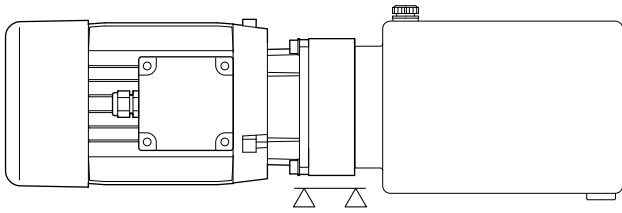

Sect. VII - Transmission kit DC motors



Transmission kit (only for motors on the catalog)
Type
End section VII

Specify the transmission kit whether you requested the joint and accessories assembly (without motor).

FP T **

**	Transmission kit				For DC motors
	Code	Pump	L	Ø	
01	KIT08019.000	Gr. 0.5	63.3	14	GA (350 W - Ø 80 - Page 72) GC (700 W - Ø 80 - Page 72) GB (400 W - Ø 80 - Page 72) GD (800 W - Ø 80 - Page 72)
	KIT08019.001	Gr. 1	46.9	14	

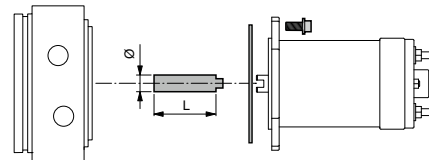

**	Transmission kit				For DC motors
	Code	Pump	L	Ø	
02	KIT08019.002	Gr. 0.5	64.5	14	AA (1500 W - Ø 115 - Page 73) EN (1600 W - Ø 115 - Page 73) AB (2000 W - Ø 115 - Page 73) ES (2200 W - Ø 115 - Page 73) GN (1600 W - Ø 115 - Page 74) GP (2200 W - Ø 115 - Page 74)
	KIT08019.003	Gr. 1	48.2	14	

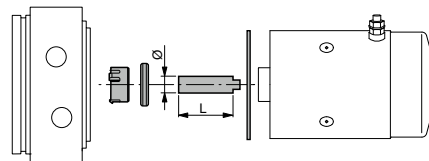

**	Transmission kit				For DC motors
	Code	Pump	L	Ø	
03	KIT08019.004	Gr. 1	45.4	20	GJ (3000 W - Ø 125 - Page 74) FB (3000 W - Ø 125 - Page 74)

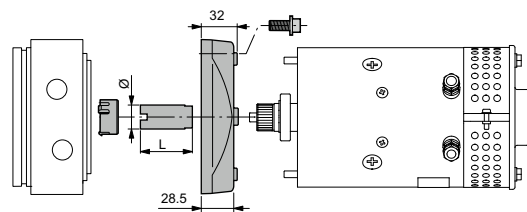

Note: in ventilated motors (accessory "D" page 74) the transmission is included in the kit ventilation

Sect. VII - Transmission kit AC motors



Transmission kit (only for motors on the catalog)
Type
End section VII

Specify the transmission kit whether you requested the joint and accessories assembly (without motor).

FP T **

	Transmission kit						For AC motors		Page
	Code	Pump	L	Ø	L1	Z	Ref.	Size	
1R	KIT08019.009	Gr. 0.5	47.1	14	30	62.7	R	63 (B14)	79
	KIT08019.010	Gr. 1	30.6	20	30	42.8			

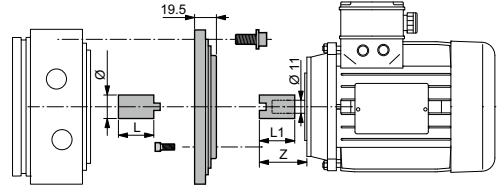

	Transmission kit						For AC motors		Page
	Code	Pump	L	Ø	L1	Z	Ref.	Size	
1L	KIT08019.011	Gr. 0.5	47.1	14	26.5	42	L	71 (B14)	78
	KIT08019.012	Gr. 1	30.7	20	26.5	42			

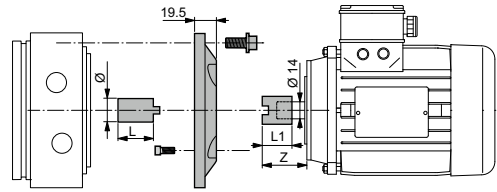

	Transmission kit						For AC motors		Page
	Code	Pump	L	Ø	L1	Z	Ref.	Size	
1M	KIT08019.013	Gr. 0.5	47.1	14	38	53	M	80 (B14)	78
	KIT08019.014	Gr. 1	30.7	20	38	53			

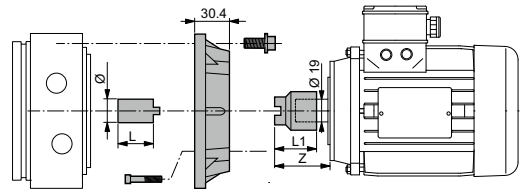

	Transmission kit						For AC motors		Page
	Code	Pump	L	Ø	L1	Z	Ref.	Size	
1N	KIT08019.015	Gr. 0.5	47.1	14	45.4	63	N	90 (B14)	78
	KIT08019.016	Gr. 1	30.7	20	45.4	63			

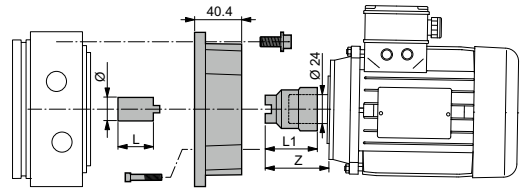

	Transmission kit						For AC motors		Page
	Code	Pump	L	Ø	L1	Z	Ref.	Size	
1P	KIT08019.017	Gr. 0.5	62.9	14/20	57	81.5	P	100-112 (B14)	78
	KIT08019.018	Gr. 1	46.6	20	57	81.5			

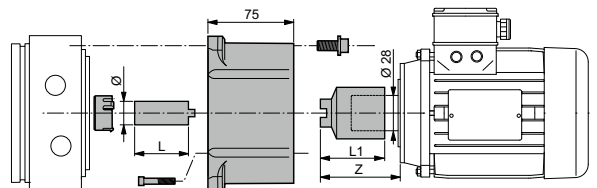

	Transmission kit						For AC motors		Page
	Code	Pump	L	Ø	L1	Z	Ref.	Size	
1S	KIT08019.005	Gr. 0.5		64.5	14		S	71 (direct fixing)	80
	KIT08019.006	Gr. 1		48.2	14				

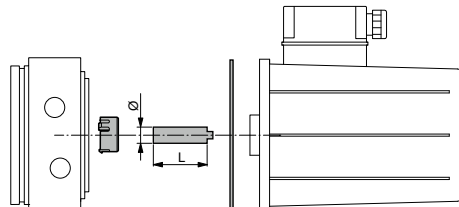

	Transmission kit						For AC motors		Page
	Code	Pump	L	Ø	L1	Z	Ref.	Size	
1T	KIT08019.007	Gr. 0.5		68	14		TV	80-90 (direct fixing)	81
	KIT08019.008	Gr. 1		51.7	20				

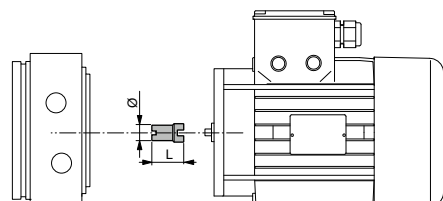

"Z" : dimension of the coupling side motor

Sect. VIII - Blocks and CETOP valves

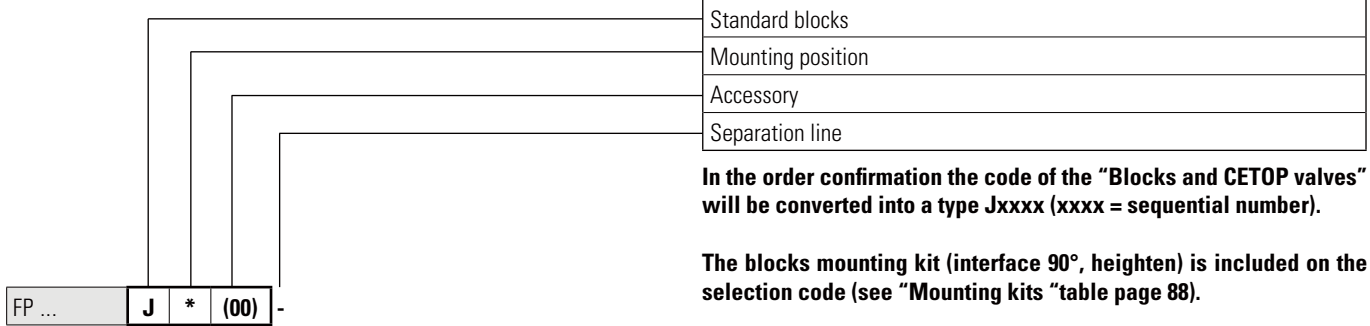

In the order confirmation the code of the "Blocks and CETOP valves" will be converted into a type Jxxxx (xxxx = sequential number).

The blocks mounting kit (interface 90°, heighten) is included on the selection code (see "Mounting kits" table page 88).

Blocks mounting on horizontal power pack

<p>J 0</p> <p>Blocks orthogonal to the axis Except AC motors ref. size M-N-P</p>	<p>J A</p> <p>Blocks orthogonal to the axis with heighten For AC motors ref. size M-N-P</p>	<p>J B</p> <p>Blocks parallel to the axis with interface 90° Except AC motors ref. size P</p>	<p>J C</p> <p>Blocks parallel to the axis with heighten and interface 90° For AC motors ref. size P</p>
--	---	---	---

The blocks can not be mounted with motors oriented in position "1" (DC motors, see page 76. AC motors, see page 82).

Blocks mounting on vertical power pack

<p>J 0</p> <p>Blocks orthogonal to the axis Except AC motors ref. size M-N-P</p>	<p>J A</p> <p>Blocks orthogonal to the axis with heighten For AC motors ref. size M-N-P</p>	<p>J B</p> <p>Blocks parallel to the axis with interface 90° Except AC motors ref. size P</p>	<p>J C</p> <p>Blocks parallel to the axis with heighten and interface 90° For AC motors ref. size P</p>
--	---	---	---

The blocks can not be mounted with motors oriented in position "1" - DC motors, see page 76. AC motors, see page 82.

Sect. VIII - Blocks and CETOP valves

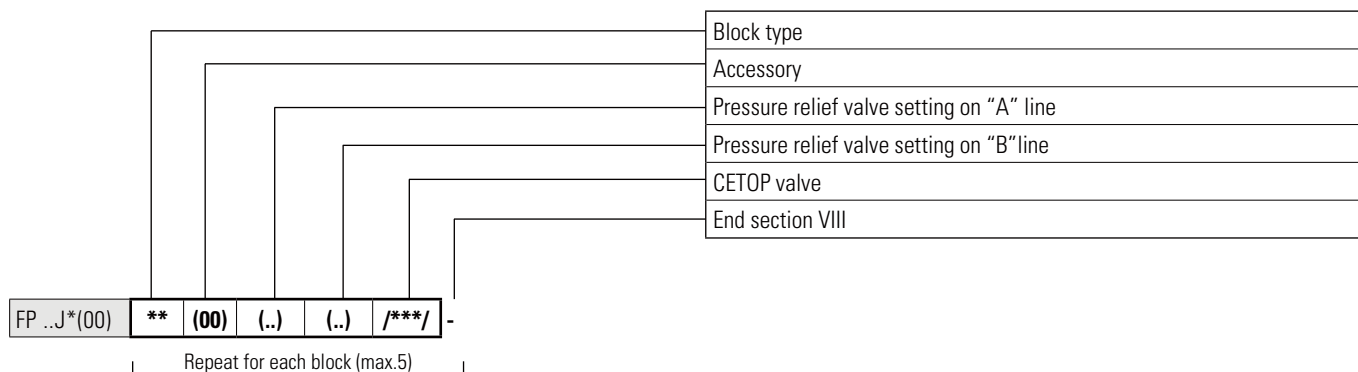

****** (00) (..) (..) /***/ - **Block type**

**	(00)	(..)	(..)	Description	Code	Drawing	Scheme
A2	(00)	(0)	(0)	Middle parallel - Lateral ports G3/8"	V60403010		
A3	(00)	(0)	(0)	Middle parallel - Rear ports G3/8"	V60403001		
B2	(00)	(0)	(0)	Middle series - Lateral ports G3/8"	V60403011		
B3	(00)	(0)	(0)	Middle series - Rear ports G3/8"	V60403003		
E1	(00)	(0)	(0)	With pilot check valve on "A" port . Rear ports G1/4"	V60413002		
E2	(00)	(0)	(0)	With pilot check valve on "B" port. Rear ports G1/4"	V60413003		
E3	(00)	(0)	(0)	With pilot check valve on "A" and "B" ports. Rear ports G1/4"	V60413001		

P1 - T1: thread, closing with plug G1/8" (Plug Q26622251 + Washer Q51435012)

Sect. VIII - Blocks and CETOP valves



** (00) (..) (..) /***/ - *Block type*

**	(00)	(..)	(..)	Description	Code	Drawing	Scheme
F1	(00)	(D)	(0)	With pressure relief valve on "A" port Setting 15 ÷ 50 bar - Lateral ports G1/4"	1318828		
		(E)	(0)	With pressure relief valve on "A" port Setting 50 ÷ 110 bar - Lateral ports G1/4"	1318829		
		(F)	(0)	With pressure relief valve on "A" port Setting 110 ÷ 220 bar - Lateral ports G1/4"	1318830		
		(G)	(0)	With pressure relief valve on "A" port Setting 220 ÷ 290 bar - Lateral ports G1/4"	1318831		
F2	(00)	(0)	(D)	With pressure relief valve on "B" port Setting 15 ÷ 50 bar - Lateral ports G1/4"	1318832		
		(0)	(E)	With pressure relief valve on "B" port Setting 50 ÷ 110 bar - Lateral ports G1/4"	1318833		
		(0)	(F)	With pressure relief valve on "B" port Setting 110 ÷ 220 bar - Lateral ports G1/4"	1318834		
		(0)	(G)	With pressure relief valve on "B" port Setting 220 ÷ 290 bar - Lateral ports G1/4"	1318835		
F3	(00)	(D)	(D)	With pressure relief valve on "A" and "B" Setting 15 ÷ 50 bar - Lateral ports G1/4"	1318836		
		(E)	(E)	With pressure relief valve on "A" and "B" Setting 50 ÷ 110 bar - Lateral ports G1/4"	1318837		
		(F)	(F)	With pressure relief valve on "A" and "B" Setting 110 ÷ 220 bar - Lateral ports G1/4"	1318838		
		(G)	(G)	With pressure relief valve on "A" and "B" Setting 220 ÷ 290 bar - Lateral ports G1/4"	1318839		

P1 - T1: thread, closing with plug G1/8" (Plug Q26622251 + Washer Q51435012)

Mounting kits

Mounting kit: blocks	For No. blocks	Code
Mounting position 0-2-3	1	V60513007
	2	V60513008
	3	V60513009
	4	V60513010
Mounting position 1 (with heighten)	1	V60513011
	2	V60513012
	3	V60513013
	4	V60513014

Mounting kit: interface 90°	Code
Mounting position 2	V60513051

Mounting kit: interface 90° with heighten	Code
Mounting position 3	V60513049

The blocks mounting kit (interface 90°, heighten) is included on the selection code (see mounting position, page 85).

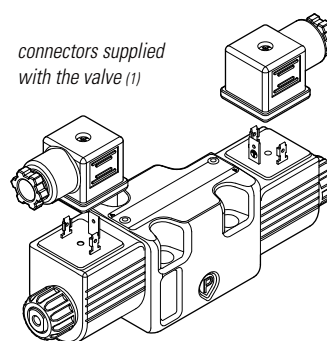

** (00) (..) (..) /***/ - **CETOP 3 valves**

/***/	Voltage	Code	Spool ⁽²⁾		Scheme	Screw kit for valve mounting
			Type	Mounting		
/000/	Without valve					
/001/	24 VDC (M)	ADC3E01CM001	01	C		V60513015
/002/	12 VDC (L)	ADC3E01CL001				
/003/	24 VDC (M)	ADC3E02CM001	02	C		
/004/	12 VDC (L)	ADC3E02CL001				
/005/	24 VDC (M)	ADC3E03CM001	03	C		
/006/	12 VDC (L)	ADC3E03CL001				
/007/	24 VDC (M)	ADC3E04CM001	04	C		
/008/	12 VDC (L)	ADC3E04CL001				

1 = Valves supplied with connector. Without connector see accessories page 89

2 = More details, features and performances, see catalog Dana "Valves and Electronics" code DOC00078

Sect. IX - Accessories

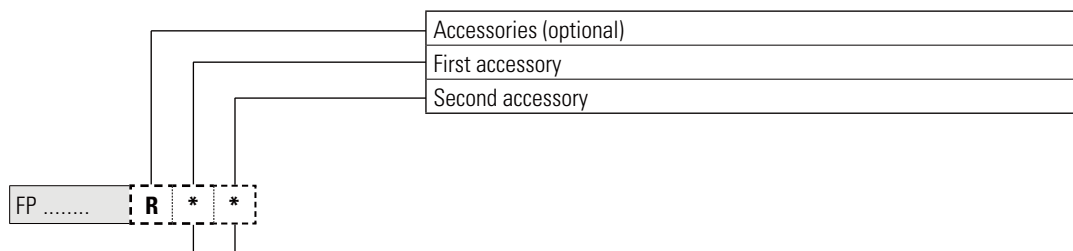

*	Description	Drawing	Code	Note
A	Standard foot, (galvanized sheet steel) thickness 2.5 mm (unassembled)		Kit (foot and screws): 17010075	All motors are compatible except orientation / 3 Tanks compatible (except for orientation / 3) S**A S**B S**C S**G S**L
B	Non-removable red plastic plug for pressure relief valve (unassembled)		Plug: 60309200	
C	Protection device for DC motors (supplied assembled)		Kit (protectin, nut, tierods, washers): 17010048	For motors: M2EN M4ES With blocks, please add the block code 91006000.000
D	High foot, (galvanized sheet steel) thickness 2 mm (unassembled)		Kit (foot and screws): 17010053	All motors are compatible except orientation / 3 Tanks compatible (except for orientation / 3) S**A S**B S**C S**D S**F S**G S**L
E	Collar in welded sheet steel, thickness 2 mm (unassembled)		Collar: 25000300 Tank fixing kit (screws and O-Ring): 17010080	
F	Without valves connectors			

Examples with FPA endhead

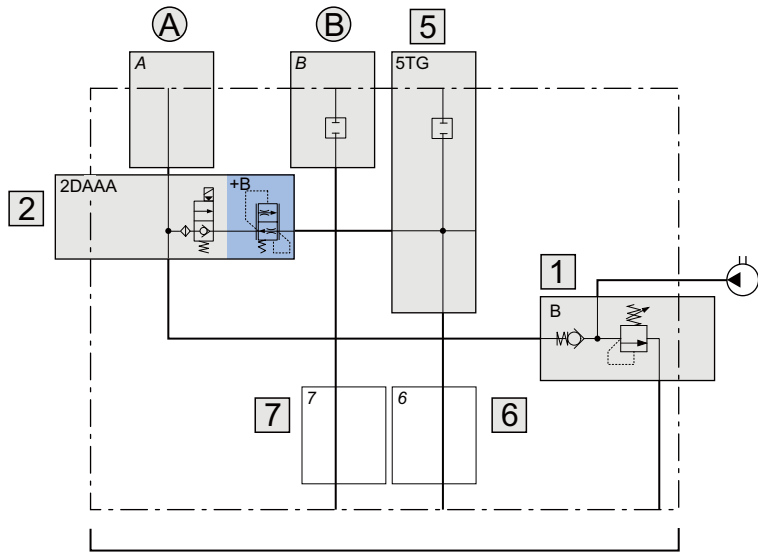

FPA 0 F1 2DAAA+B 5TG -03 - ..

Cavity	Code	Description	Page
-	0	Thread ports P-T G1/4" (blocks interface)	13
1	F1	Pressure relief valve with check valve (75 ÷ 220 bar) with screw and detachable closing, standard setting 150 bar	14
2	2DAAA +B	Piloted solenoid valve normally closed, without emergency. Voltage 12 VDC + Flow control valve 1.4 l/min	16
5	5TG	Plug	18
6-7		Not specified, return lines 6 and 7 open	—
A-B	-03	Combinations plugs on ports (A= open; B= with plug)	20
-	-	End section	—

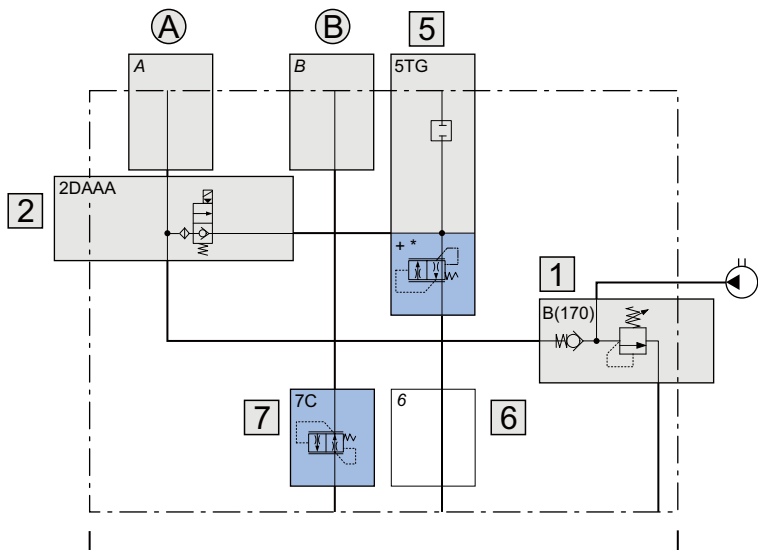

FPA 0 E1(90) 2DAAA 5TG+B 7C -00 - ..

Cavity	Code	Description	Page
-	0	Thread ports P-T G1/4" (blocks interface)	13
1	E1(90)	Pressure relief valve with check valve with screw and detachable closing, special setting 90 bar	14
2	2DAAA	Piloted solenoid valve normally closed, without emergency. Voltage 12 VDC	16
5	5TG +B	Plug + Flow control valve 1.4 l/min	18
6		Not specified, return line 6 open	—
7	7C	Flow control valve on return 7, flow 2.1 l/min	19
A-B	-00	Combinations plugs on ports (A,B= open)	20
-	-	End section	—

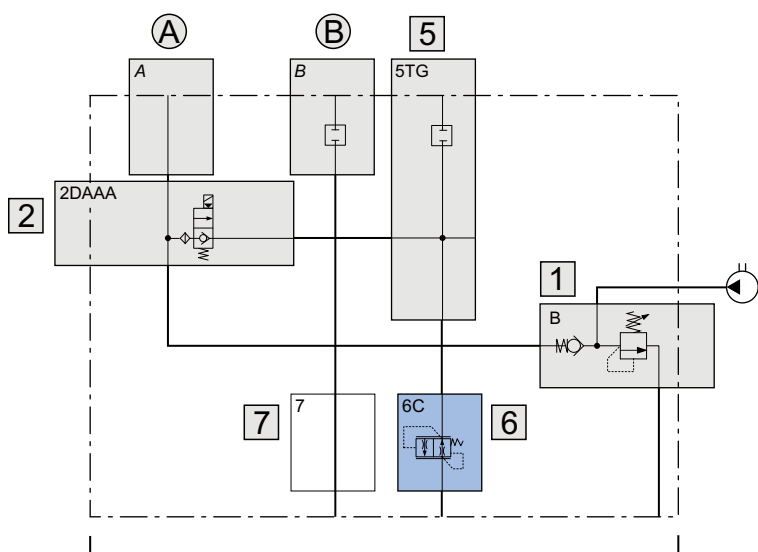

FPA 0 F1 2DAAA 5TG 6C -03 - ..

Cavity	Code	Description	Page
-	0	Thread ports P-T G1/4" (blocks interface)	13
1	F1	Pressure relief valve with check valve (75 ÷ 220 bar) with screw and detachable closing, standard setting 150 bar	14
2	2DAAA	Piloted solenoid valve normally closed, without emergency. Voltage 12 VDC	16
5	5TG	Plug	18
6	6C	Not specified, return line 6 open	19
7		Not specified, return line 7 open	—
A-B	-03	Combinations plugs on ports (A= open; B= with plug)	20
-	-	End section	—

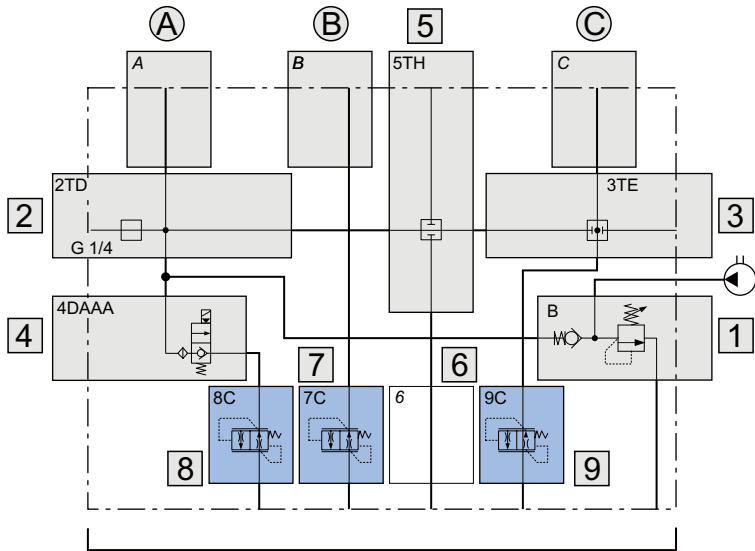

FPC 0 F1 2TD 3TE 4DAAAA 5TH 7C 8C 9C -01 - ..									
Cavity	Code	Description	Page						
-	0	Thread ports P-T G1/4" (blocks interface)	13						
1	F1	Pressure relief valve with check valve (75 ÷ 220 bar) with screw and detachable closing, standard setting 150 bar	21						
2	2TD	Plug (union G1/4)	24						
3	3TE	Plug	27						
4	4DAAAA	Piloted solenoid valve normally closed, without emergency. Voltage 12 VDC	29						
5	5TH	Plug	31						
6		Not specified, return line 6 open	—						
7	7C	Flow control valve 2.1 l/min	32						
8	8C	Flow control valve 2.1 l/min	32						
9	9C	Flow control valve 2.1 l/min	32						
A-B-C	-01	Combinations plugs on ports (A-B-C= open)	33						
-	-	End section	—						

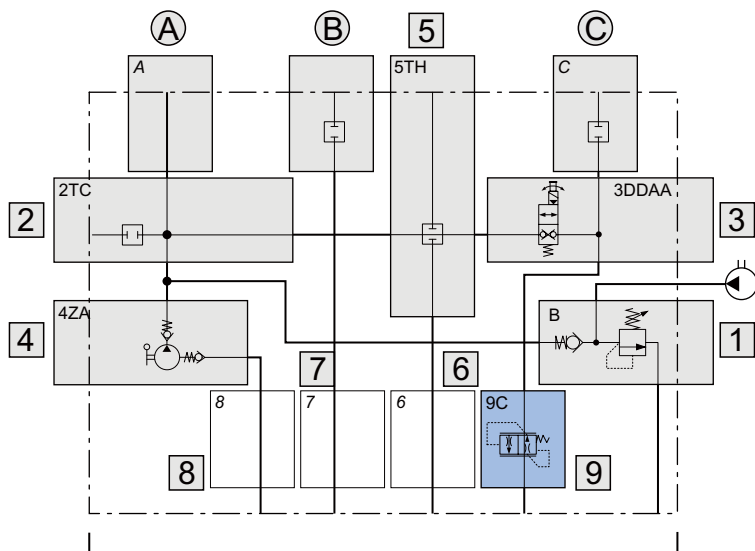

FPC 0 F1 2TC 3DDAA 4ZA 5TH 9C -05 - ..									
Cavity	Code	Description	Page						
-	0	Thread ports P-T G1/4" (blocks interface)	13						
1	F1	Pressure relief valve with check valve (75 ÷ 220 bar) with screw and detachable closing, standard setting 150 bar	21						
2	2TC	Plug	24						
3	3DDAA	Piloted solenoid valve normally closed, with emergency. Voltage 12 VDC	26						
4	4ZA	Hand pump displacement 1cc	30						
5	5TH	Plug	31						
6-7-8		Not specified, return lines 6-7-8 open	—						
9	9C	Flow control valve 2.1 l/min	32						
A-B-C	-05	Combinations plugs on ports (A = open; B-C= with plug)	33						
-	-	End section	—						

Examples with FPL endhead

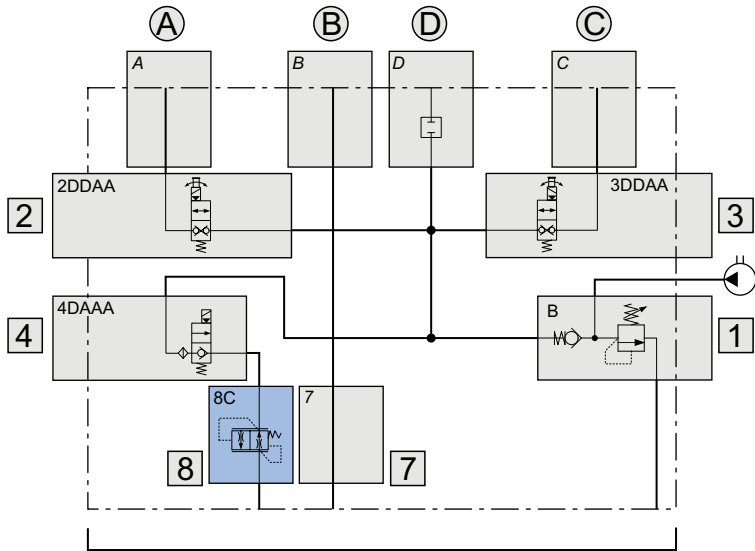

FPL	0	F1	2DDAA	3DDAA	4DAAA	8C	-04	-	..
Cavity	Code	Description							Page
-	0	Thread ports P-T G1/4" (blocks interface)							13
1	F1	Pressure relief valve with check valve (75 ÷ 220 bar) with screw and detachable closing, standard setting 150 bar							34
2	2DDAA	Direct operated solenoid valve normally closed, with emergency Voltage 12 VDC							36
3	3DDAA	Direct operated solenoid valve normally closed, with emergency Voltage 12 VDC							39
4	4DAAA	Piloted solenoid valve normal closed, without emergency. Voltage 12 VDC							42
7		Not specified, return line 7 open							—
8	8C	Flow control valve 2.1 l/min							44
A-B-C-D	-04	Combinations plugs on ports (A-B-C= open; D= with plug)							45
-	-	End section							—

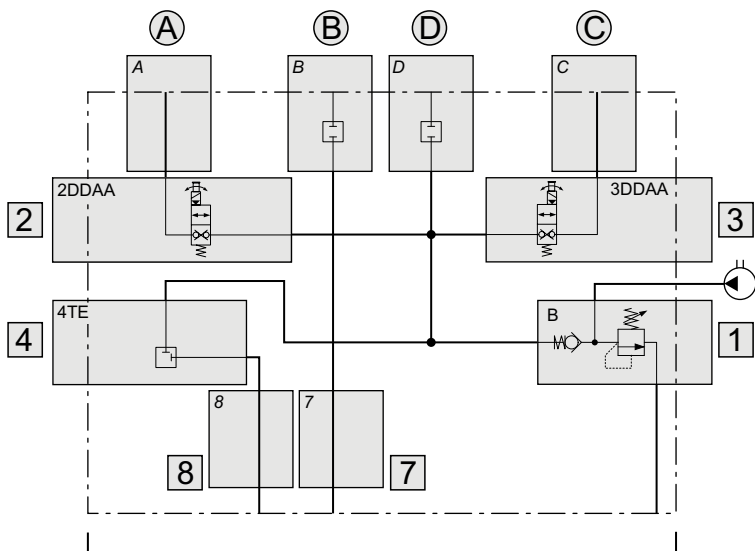

FPL	0	F1(100)	2DDAA	3DDAA	4TE	-04	-	..	
Cavity	Code	Description							Page
-	0	Thread ports P-T G1/4" (blocks interface)							13
1	F1(100)	Pressure relief valve with check valve with screw and detachable closing, special setting 100 bar							34
2	2DDAA	Direct operated solenoid valve normally closed, with emergency Voltage 12 VDC							36
3	3DDAA	Direct operated solenoid valve normally closed, with emergency Voltage 12 VDC							39
4	4TE	Piloted solenoid valve normal closed, without emergency. Voltage 12 VDC							43
7-8		Not specified, return lines 7-8 open							—
A-B-C-D	-04	Combinations plugs on ports (A-C= open; B-D= with plug)							45
-	-	End section							—

Examples with FPE endhead

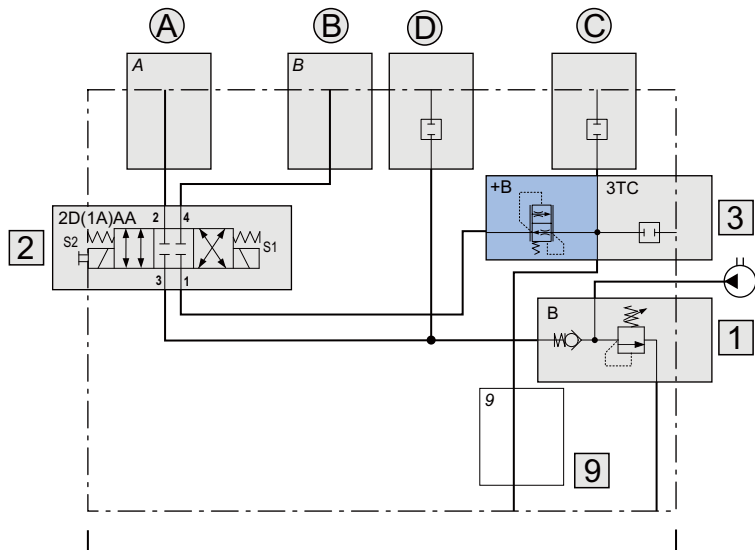

FPE 0 F1 2D(1A)AA 3TC+B -04 - ..

Cavity	Code	Description	Page
-	0	Thread ports P-T G1/4" (blocks interface)	13
1	F1	Pressure relief valve with check valve (75 ÷ 220 bar) with screw and detachable closing, standard setting 150 bar	46
2	2D(1A)AA	Directional control valve 4 way 3 positions with emergency. Voltage 12 Vdc (closed centre "C" spool)	48
3	3TC+B	Plug + Flow control valve 1.4 l/min	50
9		Not specified, return 9 open	—
A-B-C-D	-04	Combinations plugs on ports (A-B= with protection; C-D= with plug)	52
-	-	End section	—

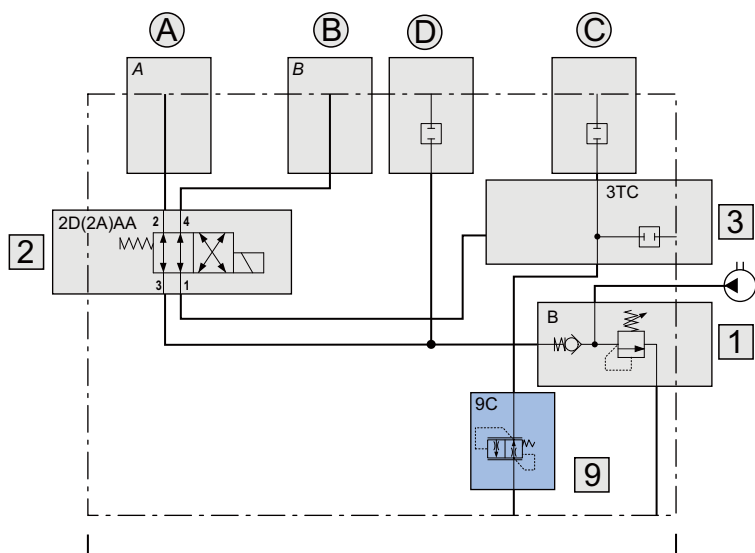

FPE 0 F1 2D(2A)AA 3TC 9C -04 - ..

Cavity	Code	Description	Page
-	0	Thread ports P-T G1/4" (blocks interface)	13
1	F1	Pressure relief valve with check valve (75 ÷ 220 bar) with screw and detachable closing, standard setting 150 bar	46
2	2D(2A)AA	Directional control valve 4 way 3 positions with emergency. Voltage 12 Vdc (closed centre "C" spool)	48
3	3TC	Plug	50
9	9C	Flow control valve 2.1 l/min	51
A-B-C-D	-04	Combinations plugs on ports (A-B= with protection; C-D= with plug)	52
-	-	End section	—



BREVINI[®]
Motion Systems

DC6A1A1_B90-000
05 2022

Product Catalog

Brevini[®] Power Units **DTR Power Packs**

Custom mini powerpacks for telescopic dock levelers

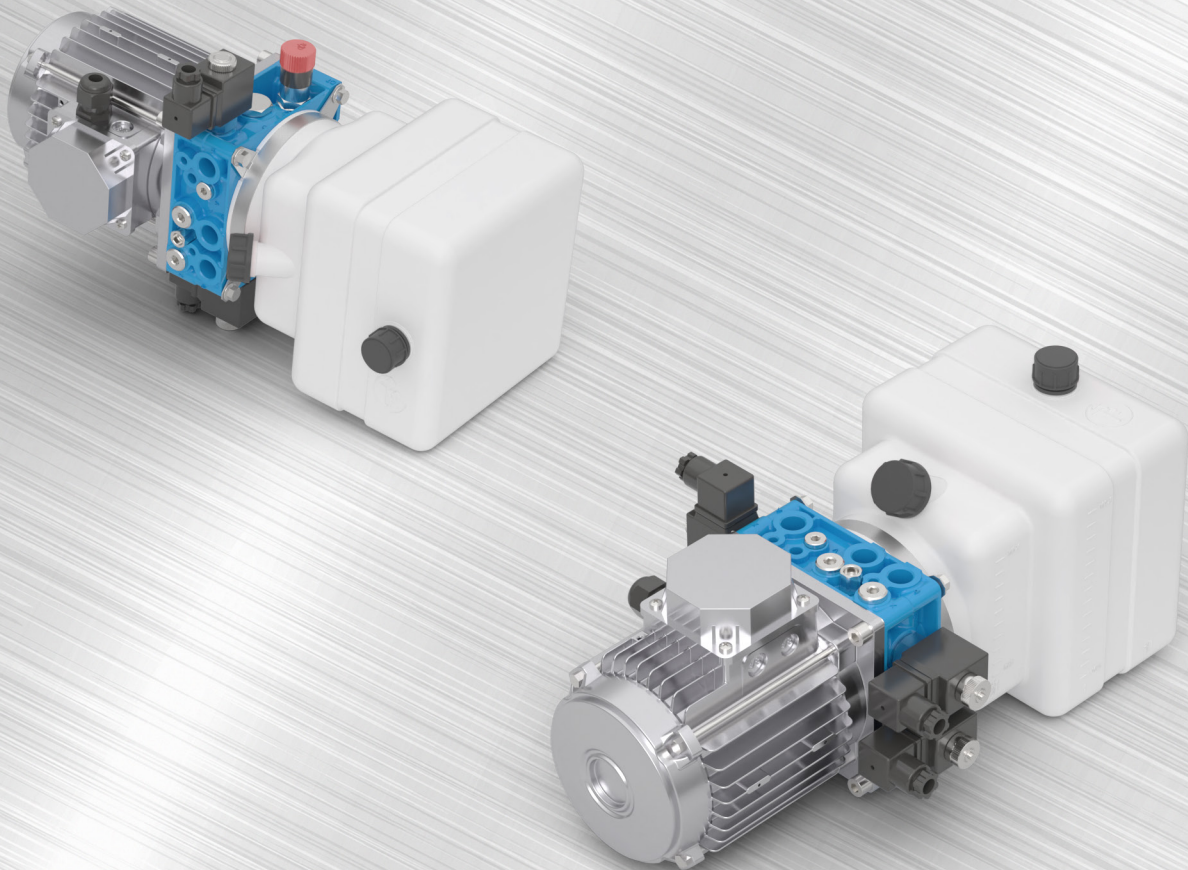

Power Packs

The DTR series power pack is an easy-to-assemble, compact electro-hydraulic unit with high flexibility and modularity



Introduction	2
Endhead configuration	3
Power pack sections	4
Selection code	5
Endhead overall dimensions	8
Cavities dimensions	9
Section I - Endhead choice	10
Section II - DTR Cavities	11
Cavity E	11
Cavity D	12
Cavity B	13
Cavity G	14
Cavity 6 (optional)	15
Cavity H	16
Section II - DTR Ports A-P-C-X-L	17
Section III - Pumps	18
Section IV - Tanks and Tubes kit	20
Section V - AC Motors	28
Section VI - Transmission kit AC motors	32
Section VII - Accessories (optional)	33
Example	34

Dana has introduced the introductive index, page symbols and bookmars, which allow you to arrive and print the relevant section faster.
 Clicking the Dana logo at the bottom page, you'll come back to the index.

The DTR series power pack is an easy-to assemble, compact, electro-hydraulic unit. It offers application driven solutions for any kind of telescopic dock levellers. This catalogue has been written to help the user to choose the components for the power pack required for the specific application. However, the catalogue cannot foresee all the combinations that may be executed, so in some cases it may be necessary to consult our local Dana Sales.

You can chose from a wide variety of components with the following specifications:

- Gear pumps - Group 1 - from 0.90 to 4.3 cc. Single and triple-phase motors with power ratings of up to 4 Kw - in a standard version or built to the customer's specifications (with minimum overall dimensions)
- Tanks in sheet steel with capacities of up to 12 litres
- Tanks in plastic with capacities of up to 10 litres

A fundamental part of the power pack is the endhead, which is made of die-cast aluminum alloy. The parts and dimensions of this component are shown below.

Operating limits

- Intermittent peak pressure: 220 bar (depending on pump type)
- Maximum flow rate: 20 l/min
- Maximum operating temperature:
 - 80°C (with sheet steel tank)
 - 70°C (with polyethylene tank)
 - 60°C (with polypropylene tank)
- Mineral-based hydraulic fluid: ISO 6743-4 (DIN 51524)
 - Minimum viscosity: 12 mm²/s
 - Maximum viscosity: 80 mm²/s
 - Maximum viscosity at start-up: 500 mm²/s
- Minimum ambient temperature -15°C
- Maximum ambient temperature 40°C (with peaks of 50°C)
- The validation of the endhead follows a life-test with 210 bar pulsed pressure repeated for 200.000 cycles



Operating pressure is controlled by the maximum pressure valve and the type of pump used (in terms of performance) may be determined by the maximum pressure valve. Therefore, it is essential not to change the maximum pressure valve. If necessary, contact our technical service.

Installation

1. The power pack must be mounted using the M10 holes on the endhead.
2. The power pack must not come into contact with sheet metal, protective guards or any parts that may vibrate and transmit noise.
3. The ports on the endhead have been identified by the letters X-L-P-C-A. The hydraulic connection must be made with fittings with cylindrical thread and with copper or rubber sealing gaskets (O-rings).
4. After the electrical connections have been made, check the direction of motor rotation by executing short pulses of 1 second each (max.): the motor must turn anti-clockwise, as shown in the figure.

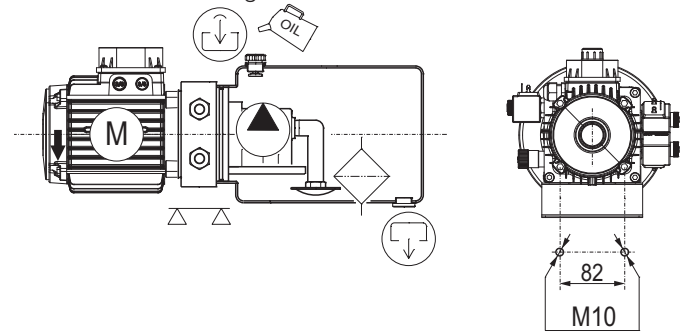

The tank must be filled with new mineral-based, ISO 6743/4 fluid: it is important to filter the fluid while filling the tank.

Symbology

	Important data/information
	Mounting endhead side
	Ground floor
	Electrical connection boxes on AC motors
	Fill plug with breather and level stick
	Fill plug with breather
	Standard plug (closed)
	Standard oil fill plug
	Fill plug with breather
	Fill plug
	Fill plug with check valve
	Fill plug with back check
	Drain plug with magnet
	Plug (or level stick) with visual indicator
	Drain plug
*	Fields to be completed

Power pack endhead configuration

DTR

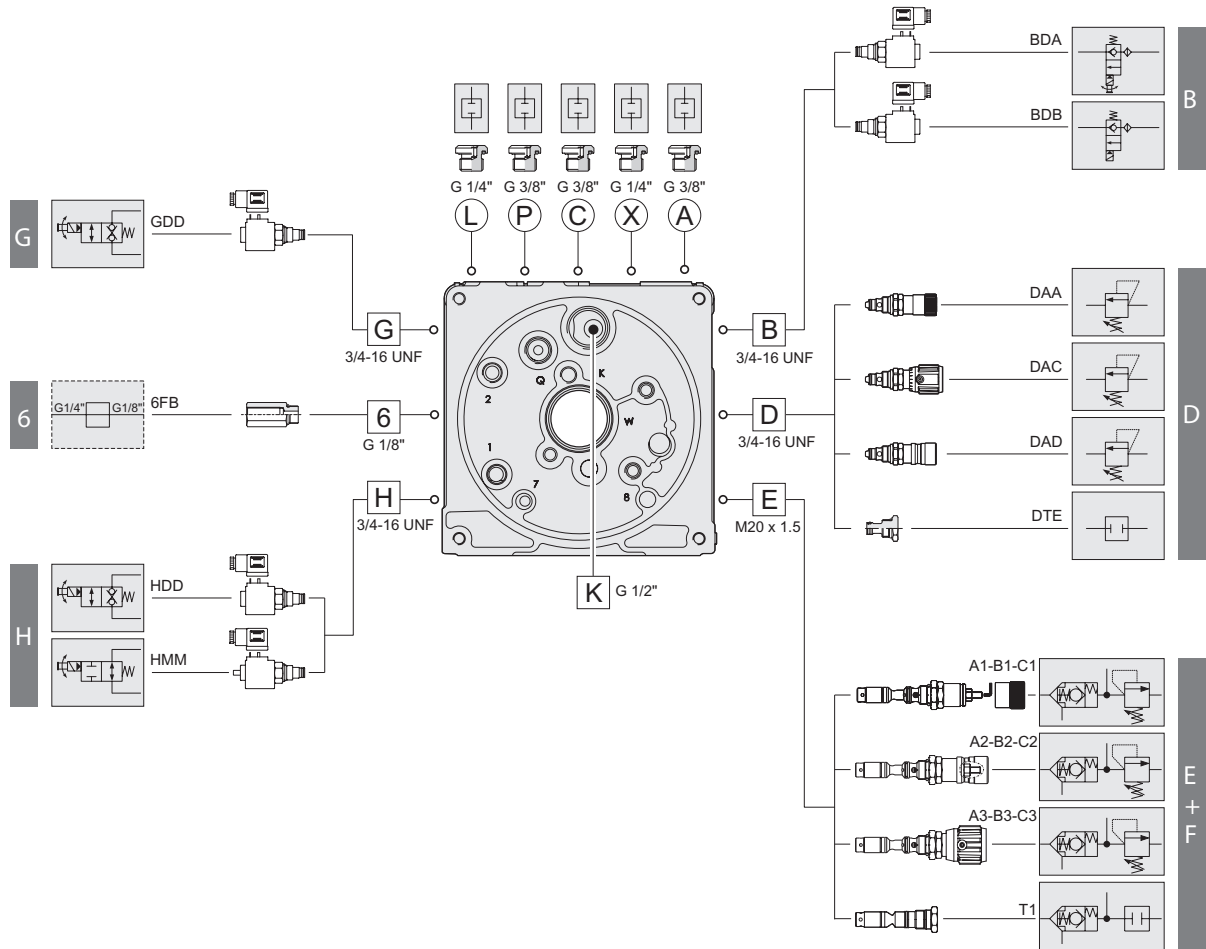

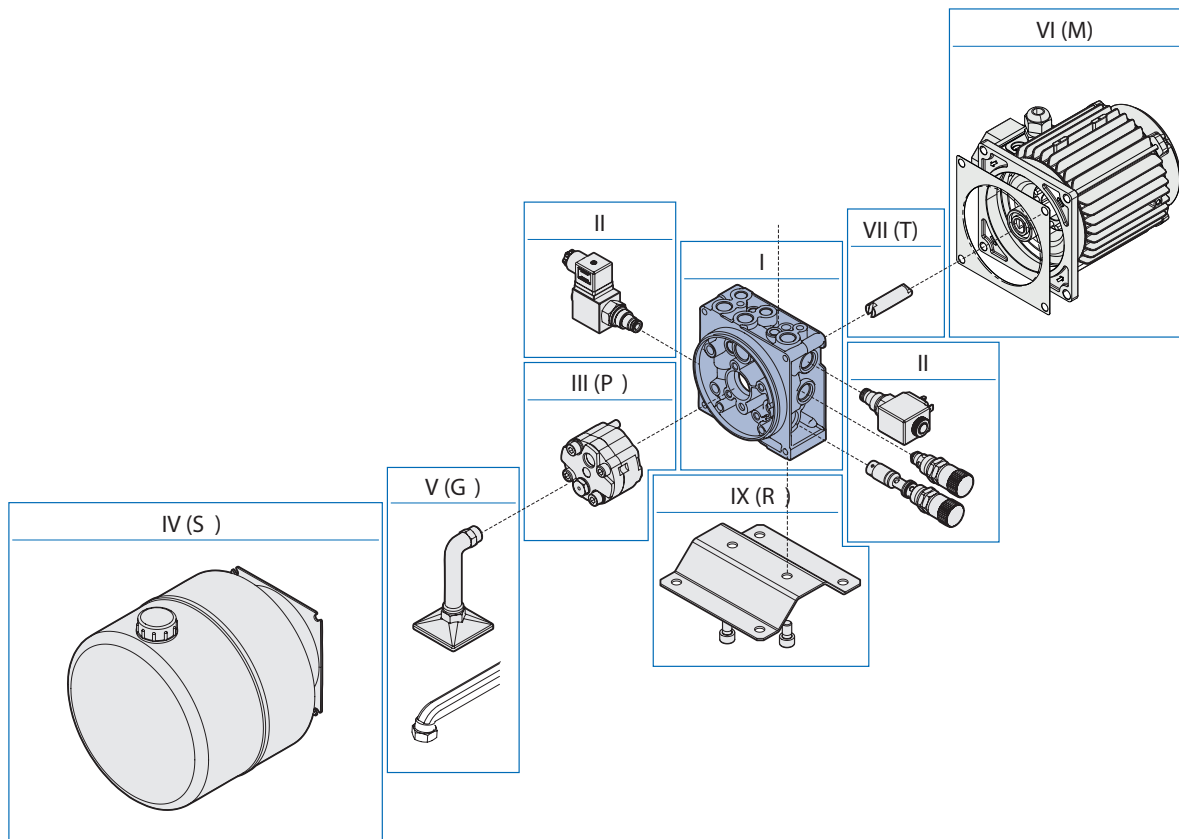

With its great modularity, the DTR series of power packs can create multiple configurations which satisfy requirements in a wide range of applications. To make it easier to choose components, the power pack is subdivided into sections.

Section I - Serie, Flange Type, Valves on Cavity E+F

DTR Series Powerpacks are based on the Flange features. The Flange is the core of the unit, on the flange are mounted all the valves, the pump, the motor and the reservoir. The DTR Flange is available in several Versions (with different tooling options). The Flange Version must be chosen depending on the type of Hydraulic Circuit Layout required. Together with the Flange Version, it is required to select the Valves to be mounted in the Various Cavities E+F (Main Pressure Relief Valve).

Section II - Valves

Depending on the Type of Hydraulic Circuit Layout to be realized, it is required to select the Valves for each of the available Cavities. In order to correctly build up the Ordering Code, it is required to use the following procedure. Peripheral Cavities (it is mandatory to mention all the Cavities in sequential Order): starting from Cavity D, mention all the Cavities and the Valves, Plugs or Fittings to be mounted in said Cavity. Internal Cavities, mention the Internal Cavities where a Valve (usually a Return Line Valve) is mounted. Outputs, see description in the Table.

Section III- Pumps

It is mandatory to mention this section, defined by the letter P. Depending on the required features, select the pump from the table provided.

Section IV - Tanks

This section is defined by the letter S. Depending on the required features, select the reservoir from the list provided. If no Reservoir is required, and also no Suction / Return Kit is required, please omit this section. If no Reservoir is required, but a Suction / Return Kit is required, please jump to Section V (defined by letter G).

Section V -Tubes Kit (suction and return, only for tanks on the catalog)

This section is defined by the letter G. In order to define this Section, please select the Reservoir Type anyways.

Section VI - Motors

This section is defined by the letter M. Depending on the Type of Hydraulic Circuit Layout to be realized, it is required to Select the Motor Type. If no Motor is required, and no Transmission Kit is required, please omit this section. If no Motor is required, but a Transmission Kit is required, please jump to Section VII (defined by letter T).

Section VII - Transmission Kit (only for motors on the catalog)

This section is defined by the letter T. Select the kit as per Table provided.

Section VIII - Accessories

This section it is not mandatory, is defined by the letter R. Check the available options in the list provided. Accessories must be listed in Alphabetical Order.

SECTION I - SERIE, ENDHEAD, VALVES ON CAVITY 1 AND 1R

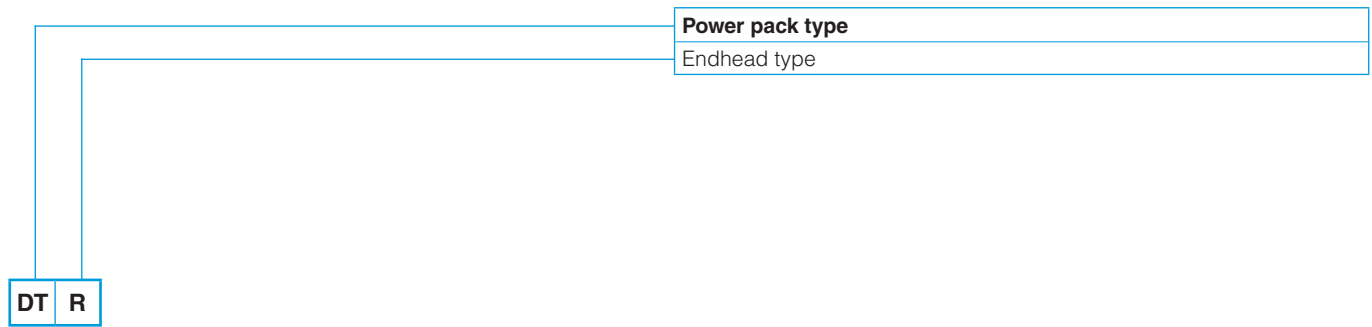

SECTION II - VALVES

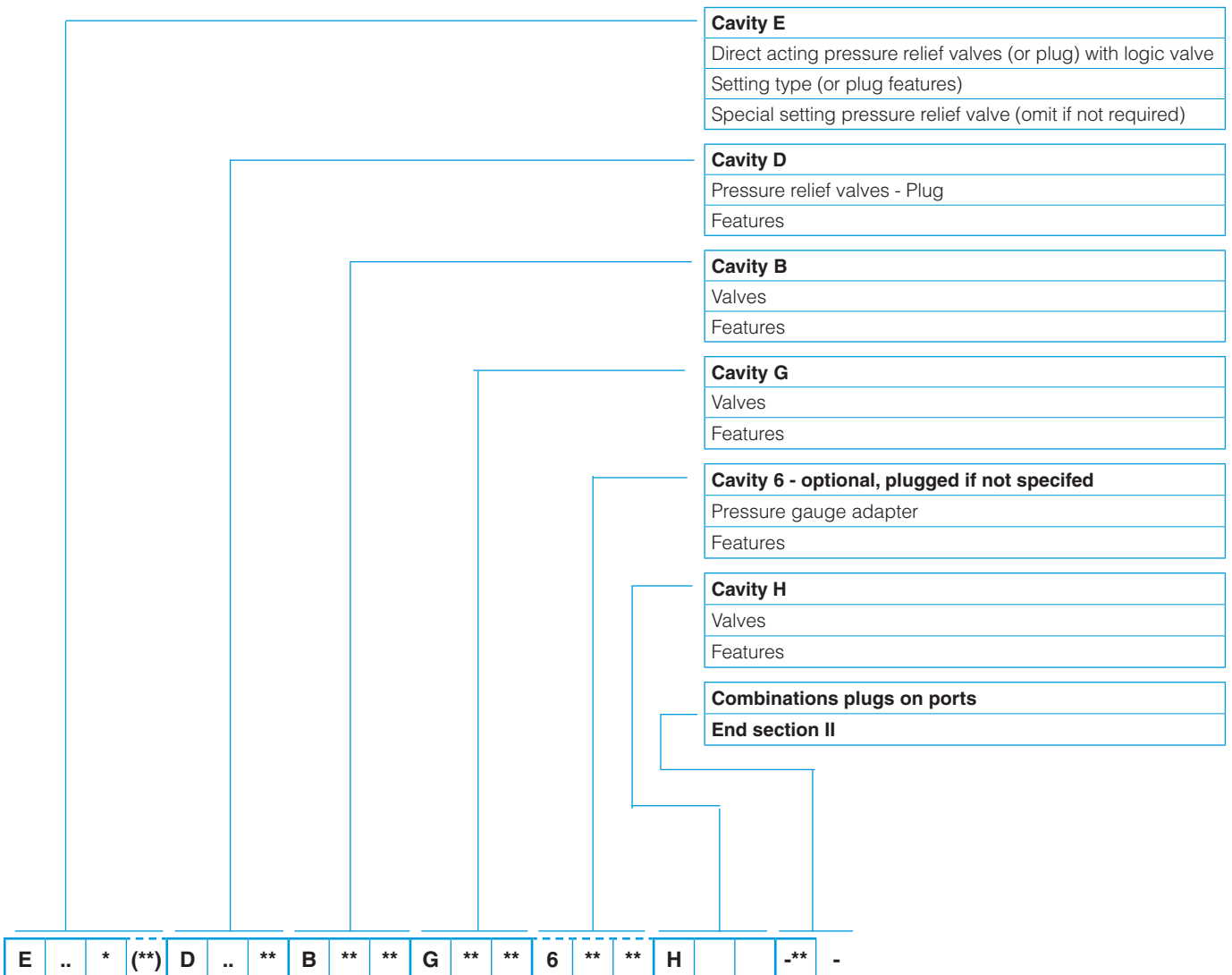

Selection code

6

i

SECTION III - PUMPS

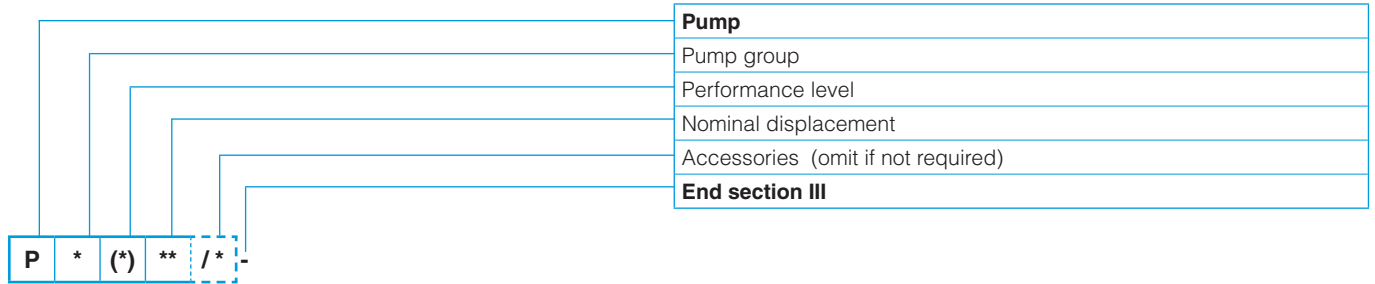

SECTION IV - TANKS and TUBES KIT

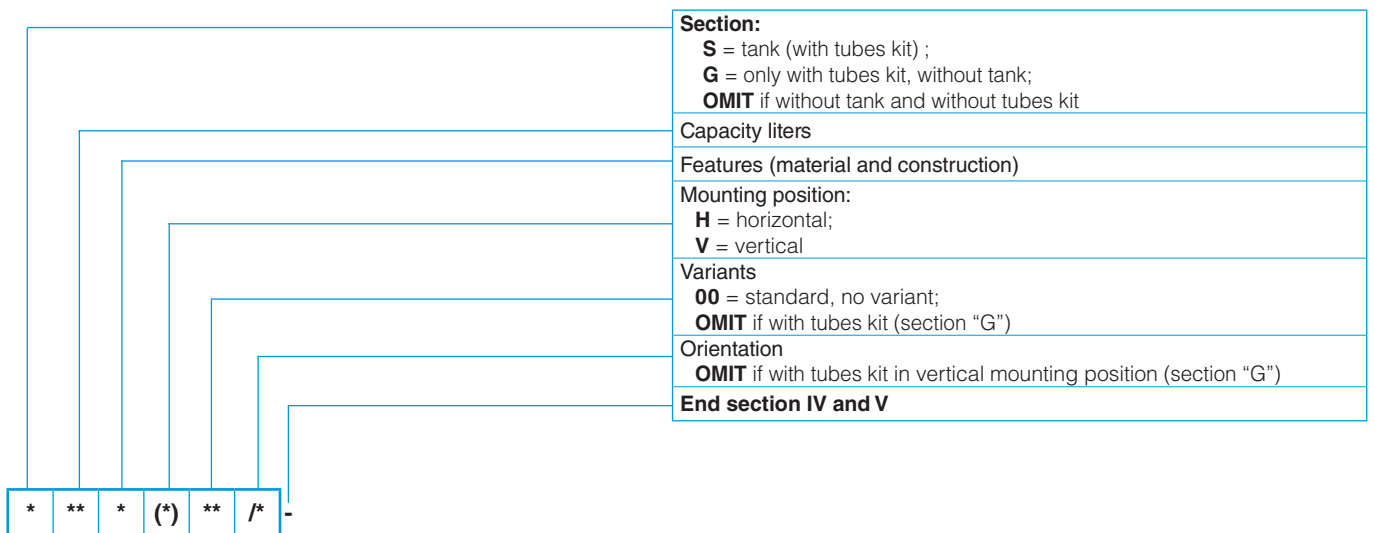

SECTION V - MOTORS

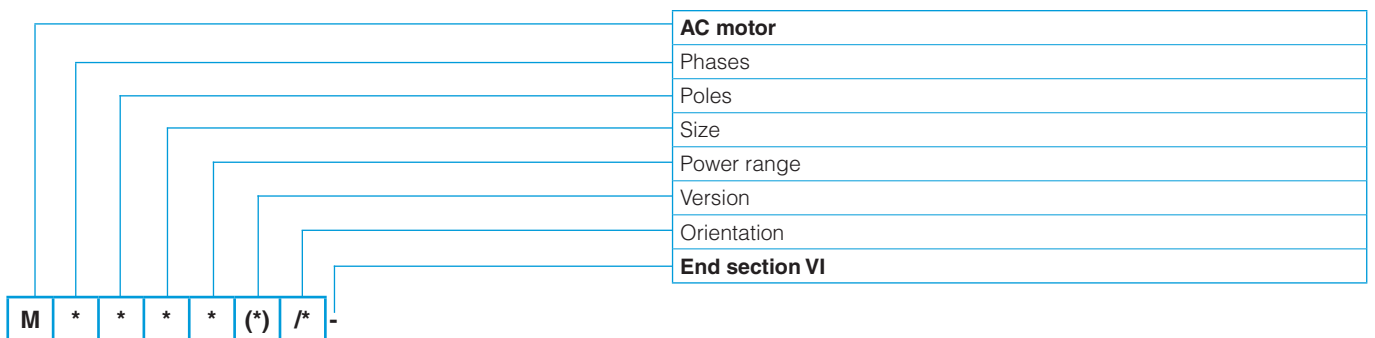

SECTION VI - TRANSMISSION KIT (only for motors on the catalog)

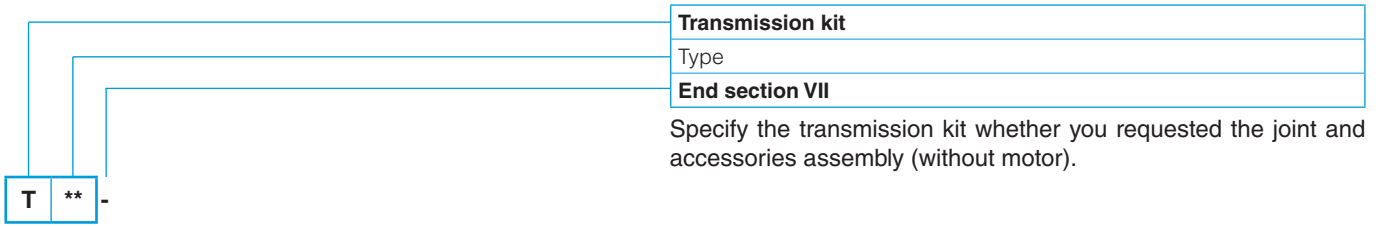

SECTION VII - ACCESSORIES

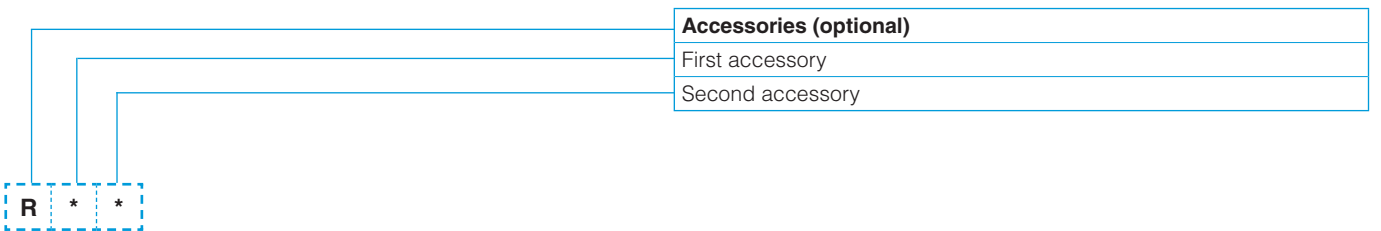

Endhead overall dimensions

Cavities on endhead:

Cavity		Thread
X-L	Ports	G1/4"
P-C-A	Ports	G3/8"
E	Peripheral	M20 x 1.5
D-B-G-H	Peripheral	3/4" 16 UNF
Y	Peripheral	M10 x 1
6	Peripheral pressure gauge	G1/8" STD plugged
K	Return	G1/2"
Q	Return	G1/4"
7-8	Return	Ø 8 not thread
W	Return	Ø 10 not thread

There are three types of cavities:

- Peripheral cavities, which can be accessed externally
- Return cavities, inside of the tank.
- Ports

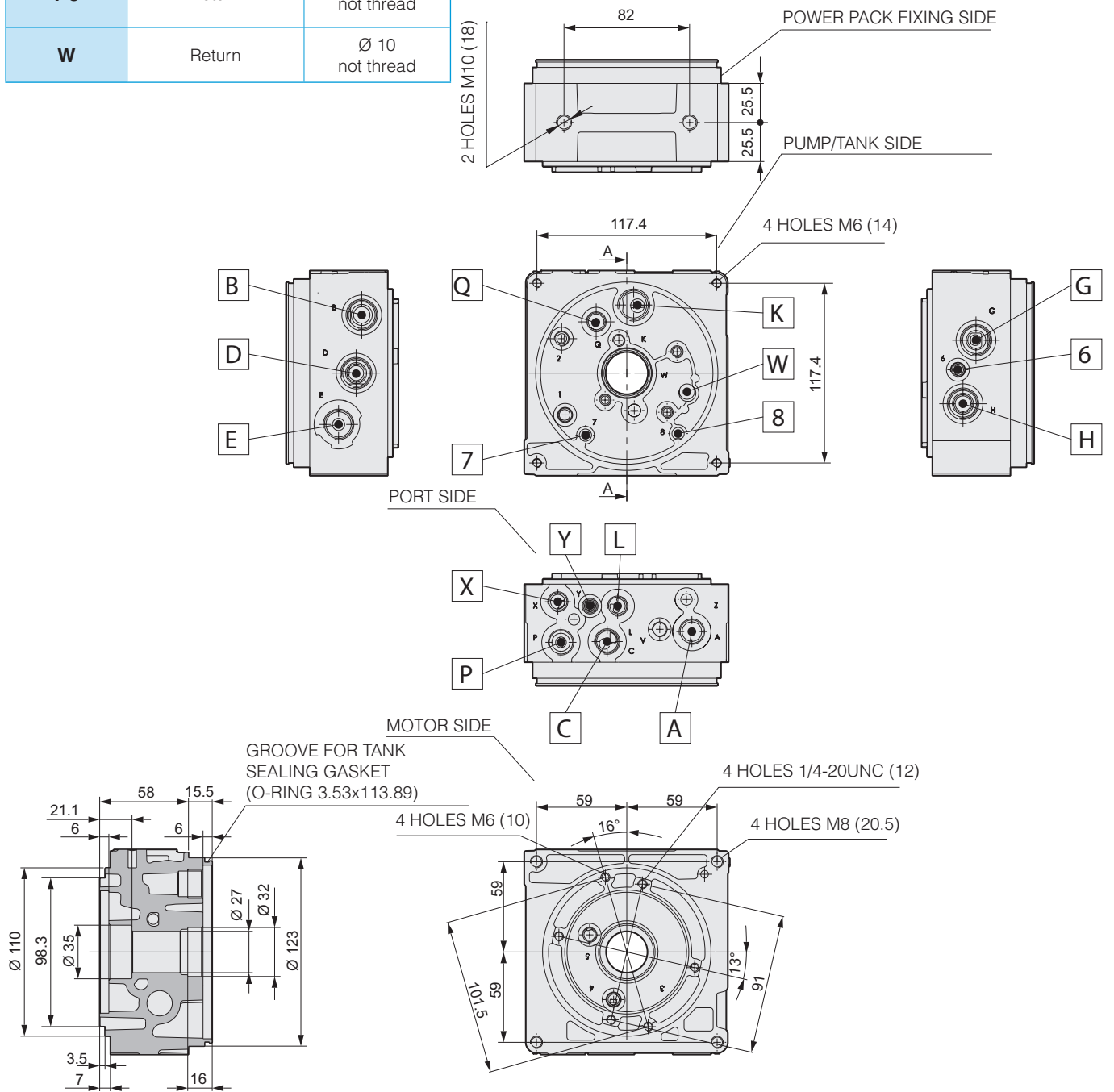

In the drawing are shown the common dimensions.

	Cavity	Thread	Drawing
E	Peripheral	M20 x 1.5	<p style="text-align: right;">CN044003</p> <p>Technical drawing of cavity CN044003. The drawing shows a cross-section of a cylindrical cavity with various diameters and lengths. Key dimensions include: outer diameter $\varnothing 32$, inner diameter $\varnothing 21^{+0.05}$, and a pre-drilled hole $\varnothing 20.4^{+0.04}_{-0.01}$ with a prefinish of $\varnothing 18.5$. The thread is M20 x 1.5. Other diameters include $\varnothing 0.15$, $\varnothing 0.03$, $\varnothing 11$ max., $\varnothing 16.5^{+0.05}_{-0.01}$, and $\varnothing 17.5^{+0.05}_{-0.01}$. Lengths are specified as 77.5 max, 69 min, 47 max, 26 min, 19 max, 12 min, 47.0 min, 13.0 min, 19.0 min, and 78 ± 0.05. Surface finishes include $3.2/\sqrt{c}$ and 0.03 A. A note indicates '77 (ratio min. alesato min. bored)'. A section line A-A is shown.</p>
D B G H	Peripheral	3/4" 16 UNF	<p style="text-align: right;">CD018014</p> <p>Technical drawing of cavity CD018014. The drawing shows a cross-section of a cylindrical cavity with a 3/4" 16 UNF thread. Key dimensions include: outer diameter $\varnothing 26$, inner diameter $\varnothing 20.6^{+0.1}$, and a pre-drilled hole $\varnothing 20.6^{+0.1}$. The thread is 3/4" 16 UNF. Other diameters include $\varnothing 0.02$, $\varnothing 0.05$, $\varnothing 11.5$ max., and $\varnothing 12.7^{+0.05}_0$. Lengths are specified as 30.5 ± 0.1, 19.5 ± 0.1, 17.5, 13, 2.5 ± 0.4, 9.5 min, and 17.5 max. Surface finishes include $3.2/\sqrt{c}$, 0.05 A, and 0.05 B. A note indicates 'R0.2 ± 0.05'. A section line A-A is shown.</p>
Y	Peripheral	M10 x 1	<p style="text-align: right;">CN019006</p> <p>Technical drawing of cavity CN019006. The drawing shows a cross-section of a cylindrical cavity with an M10x1 thread. Key dimensions include: outer diameter $\varnothing 15.5$, inner diameter $\varnothing 8$ H8 ($^{+0.022}_0$) with a prefinish of $\varnothing 7.8$, and a pre-drilled hole $\varnothing 8$ H8 ($^{+0.022}_0$). The thread is M10x1. Other diameters include $\varnothing 0.05$, $\varnothing 4.5 \pm 0.05$, and $\varnothing 0.02$. Lengths are specified as 28 ± 0.1, 12.5 ± 0.1, 10 min, 0.7x45°, 22.5 min, 27.5 max., and 31.5. Surface finishes include $1.6/\sqrt{c}$, 0.03 B, and 0.01. A note indicates 'R0.2 max.'. A section line A-A is shown.</p>

Section I - Endhead choice

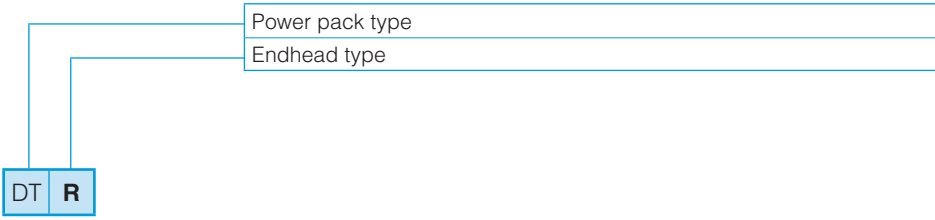

* Endhead type

* Endhead type	Cavity	Type	Thread
R	X-L	Ports	G1/4"
	P-C-A	Ports	G3/8"
	E	Peripheral	M20 x 1.5
	D-B-G-H	Peripheral	3/4" 16 UNF
	6	Peripheral pressure gauge	G1/8" STD plugged
	K	Return	G1/2"

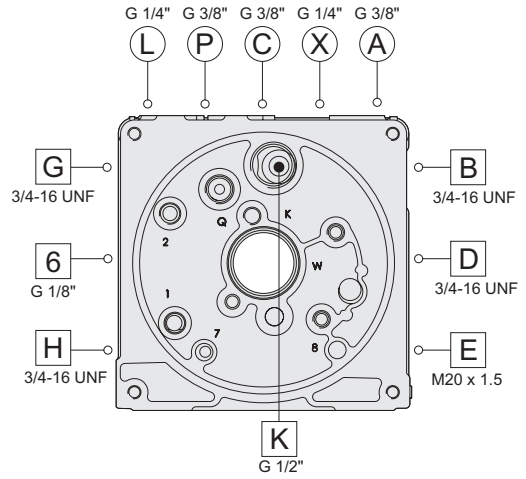

Endhead code
M17190001.000

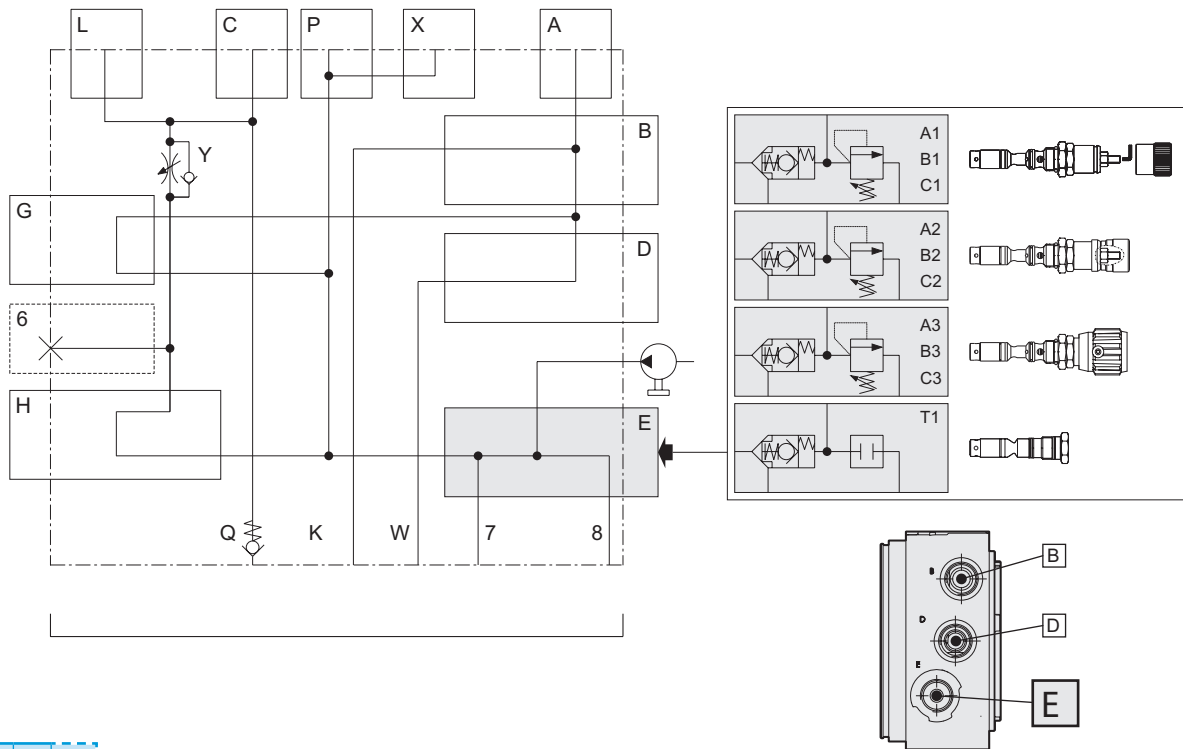
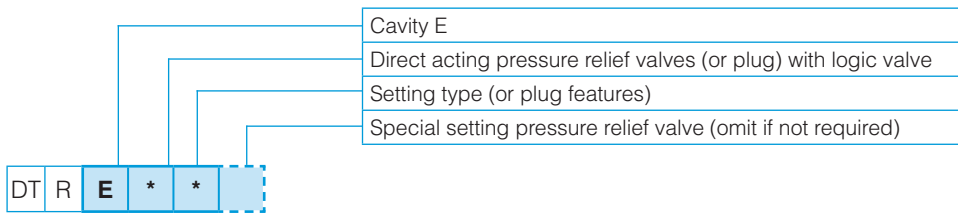

E * * (...) Direct acting pressure relief valves with logic valve

* *	Pressure (bar)	STD setting (bar)	(...) Special setting (bar)	Setting type	Code	Symbol	Drawing
A	15 ÷ 50	30	15 ÷ 50 (5 to 5)	Detachable closing	CPMK04S0001		
				Non removable closing (1)	CPMK04P0001		
				Plastic knob	CPMK04M0001		
B	35 ÷ 110	50	35 ÷ 110 (5 to 5)	Detachable closing	CPMK04S1001		
				Non removable closing (1)	CPMK04P1001		
				Plastic knob	CPMK04M1001		
C	75 ÷ 220	150	75 ÷ 220 (5 to 5)	Detachable closing	CPMK04S2001		
				Non removable closing (1)	CPMK04P2001		
				Plastic knob	CPMK04M2001		

1 = Supplied assembled. Unassembled, see accessories page 33

E * * Plug with logic valve

* *	Description	Code	Symbol	Drawing
T 1	Plug to replace pressure relief valve	27000026.000		

Section II - DTR Cavity D

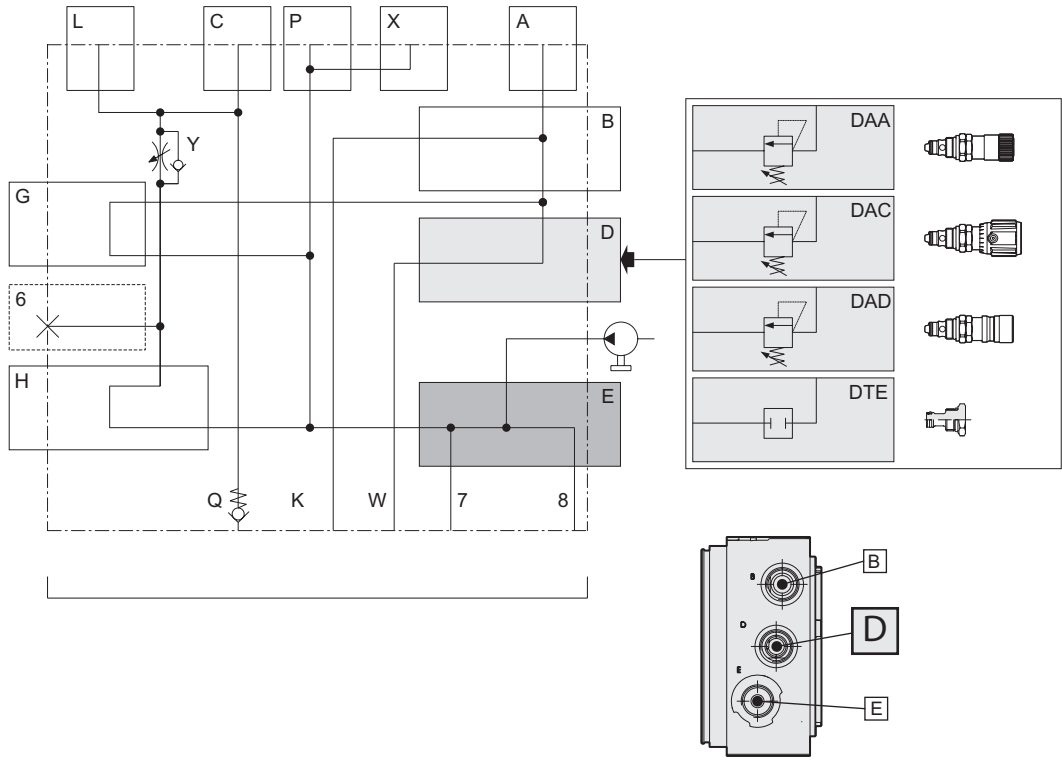
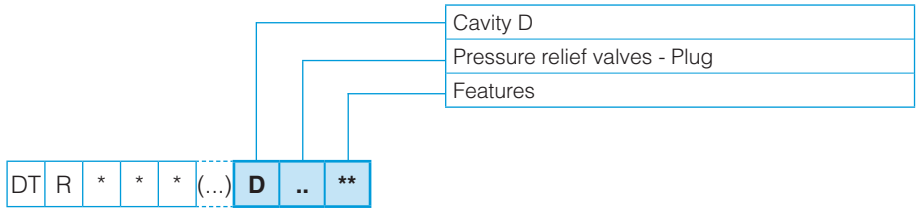

D A ** (...) Pressure relief valves

**	Description	(...) Special setting (bar)	Code	Symbol	Drawing
AD	Short screw adjustment + detachable closing	Min 15 - Max 50	CMP04AS0002		
AE		Min 35 - Max 110	CMP04AS1002		
AF		Min 75 - Max 220	CMP04AS2002		
AG	Min 160 - Max 290	CMP04AS3002			
CD	Plastic knob adjustment	Min 15 - Max 50			CMP04AM0002
CE		Min 35 - Max 110			CMP04AM1002
CF		Min 75 - Max 220	CMP04AM2002		
CG	Min 160 - Max 290	CMP04AM3002			
DD	Short screw + sealed cap	Min 15 - Max 50			CMP04AP0002
DE		Min 35 - Max 110		CMP04AP1002	
DF		Min 75 - Max 220		CMP04AP2002	
DG		Min 160 - Max 290	CMP04AP3002		

D T * Plug

*	Description	Code	Symbol	Drawing
E	Long plug 3/4 16 UNF	20003800		

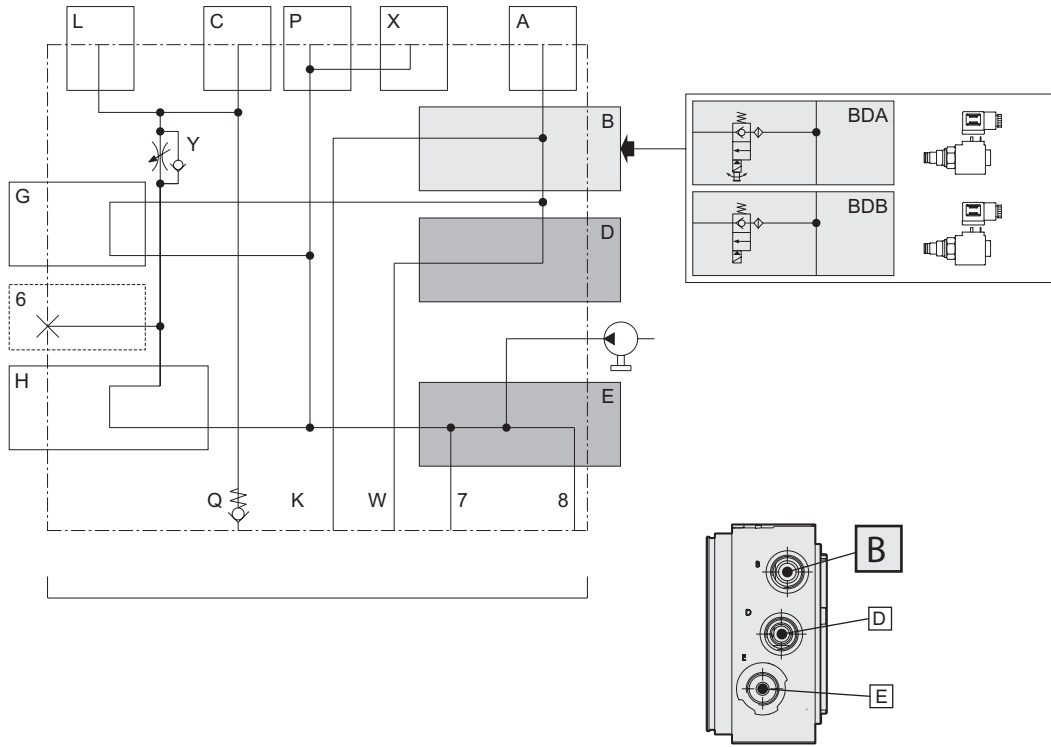
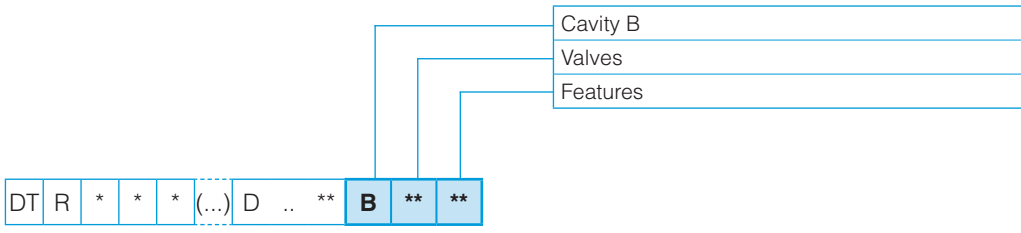

B DA ** Piloted solenoid valves normally closed, without emergency (1)

**	Description	Code (valve + connector)	Symbol	Drawing
AA	Voltage 12 Vdc	CRP0418NCASL003 + V86050002		
AB	Voltage 24 Vdc	CRP0418NCASM003 + V86050002		

B DB ** Piloted solenoid valves normally closed, with rotary emergency (1)

**	Description	Code (valve + connector)	Symbol	Drawing
AA	Voltage 12 Vdc	CRP0418NCAEL003 + V8605002		
AB	Voltage 24 Vdc	CRP0418NCAEM003 + V86050002		

1 = Valves supplied with connector. Without connector see accessories page 33

Section II - DTR Cavity G

Cavity G
Valves
Features

DT R * * * (...) D .. ** B ** ** **G** ** **

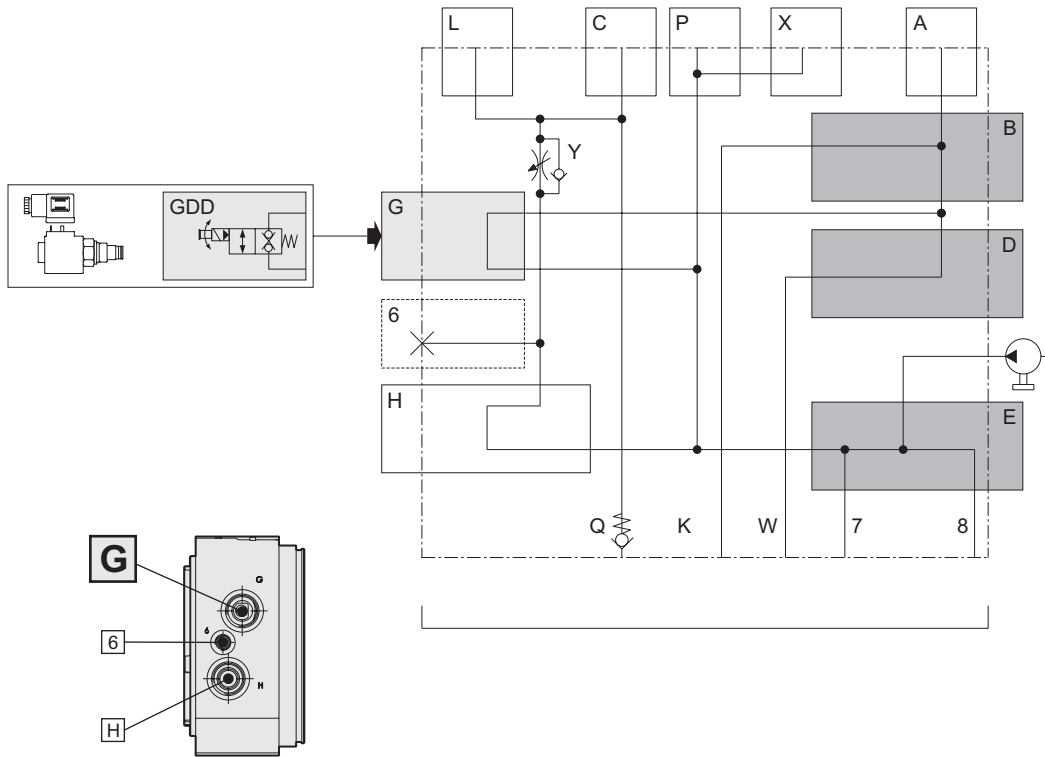

G DD ** Direct operated solenoid valve normally closed, with button emergency (1)

**	Description	Code (valve + connector)	Symbol	Drawing
AA	Voltage 12 Vdc	CRD0418NCAEL002 + V86050002		
AB	Voltage 24 Vdc	CRD0418NCAEM002 + V86050002		

1 = Valves supplied with connector. Without connector see accessories page 33

Section II - DTR Cavity 6 (optional)

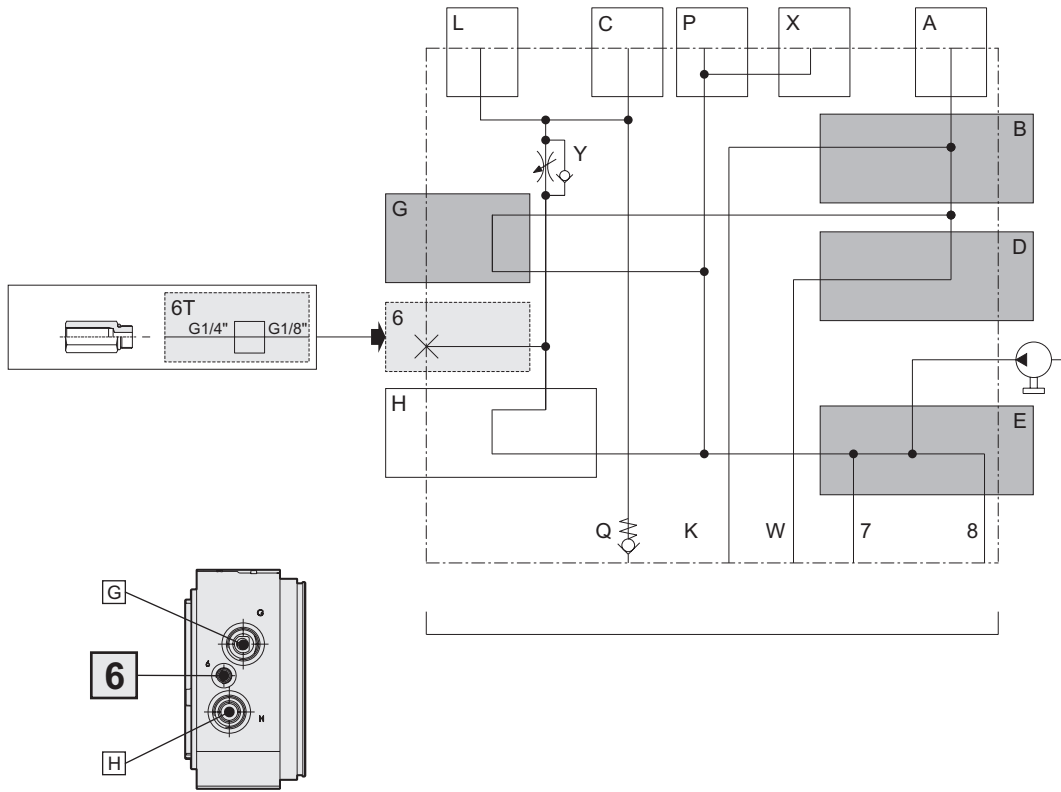
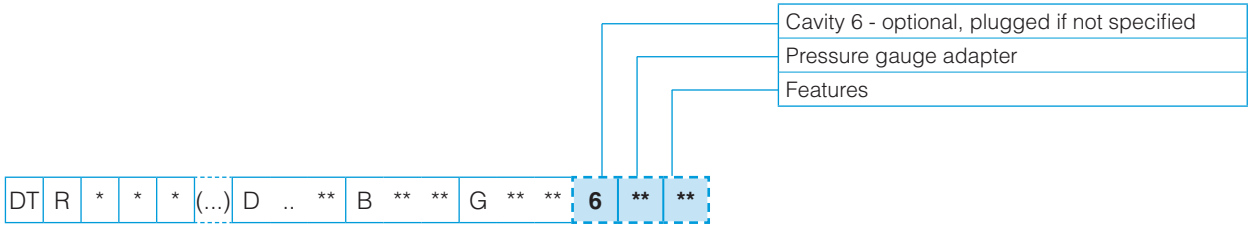

6 T * Pressure gauge adapter

*	Description	Code	Symbol	Drawing
M	Pressure gauge adapter G1/4" (male G1/8")	1321820		

Cavity H
Valves
Features

DT R * * * (...) D .. ** B ** ** G ** ** 6 ** ** **H** ** **

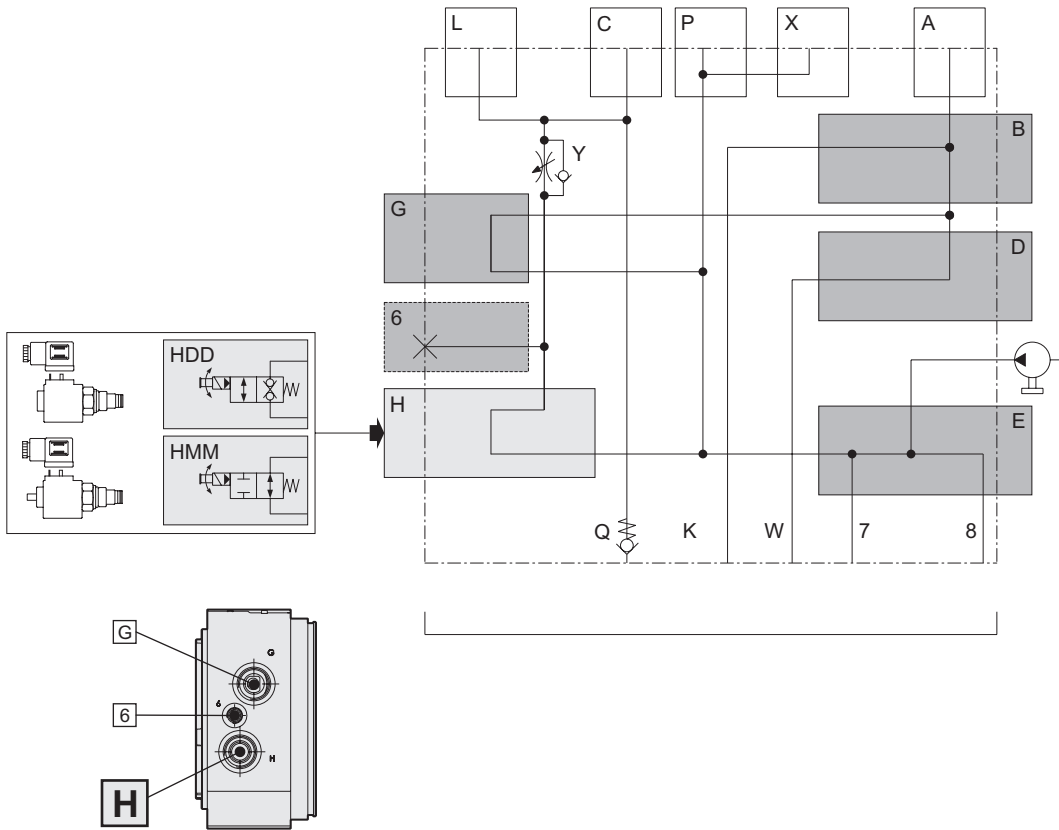

H DD ** Direct operated solenoid valve normally closed, with button emergency (1)

**	Description	Code (valve + connector)	Symbol	Drawing
AA	Voltage 12 Vdc	CRD0418NCAEL002 + V86050002		
AB	Voltage 24 Vdc	CRD0418NCAEM002 + V86050002		

H MM ** Direct operated solenoid valve normally opened, with button emergency (1)

**	Description	Code (valve + connector)	Symbol	Drawing
AA	Voltage 12 Vdc	C2V0422NAAEL002 + V86050002		
AB	Voltage 24 Vdc	CRD0418NCAEM002 + V86050002		

1 = Valves supplied with connector. Without connector see accessories page 33

Combinations plugs on ports
End section II

DT R * * * (...) D .. ** B ** ** G ** ** 6 ** ** H ** ** -**

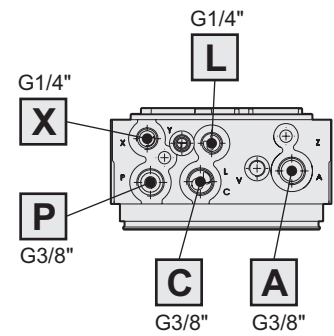
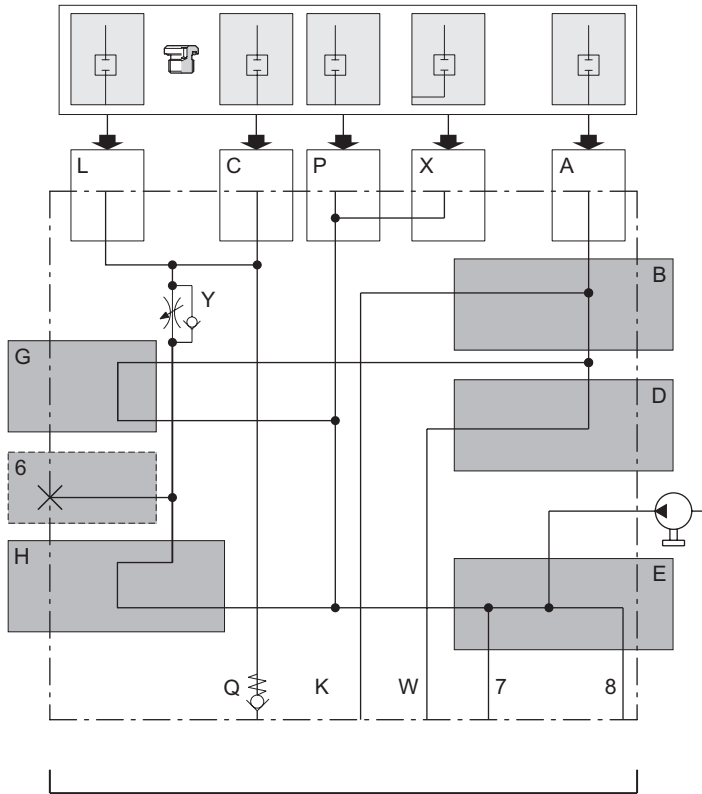

-** Plugs combinations

-**	A	P	C	X	L
-00	↑	↑	↑	⊗	⊗
-01	↑	⊗	⊗	↑	↑
-02	↑	⊗	↑	↑	⊗
-03	↑	⊗	↑	↑	↑

Symbols description

Type	Description	Thread	Code	Symbol	Drawing
⊗	Port closed with plug	G 1/4"	20024000	⊞	
		G 3/8"	Q26630006		
↑	Port open		—	—	—

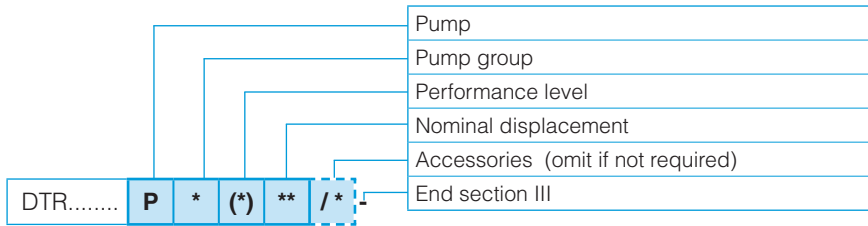

P 1 (2) ** Pumps group 1 with vent valve - Performance level 2

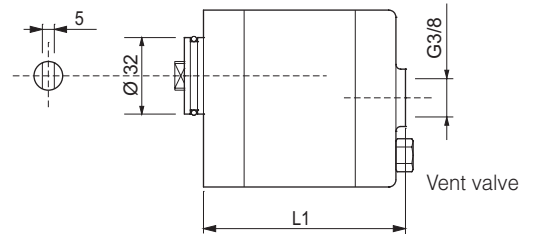

**	Nominal displacement	Tolerance on geometric displacement	P2 bar	P3 bar	Code complete kit	L1 mm
09	0.90 cc	0.83 ÷ 0.95	210	250	17050088.014	42.2
12	1.20 cc	1.10 ÷ 1.30	210	250	17050005.014	43.5
17	1.70 cc	1.50 ÷ 1.70	210	250	17050006.014	45.3
22	2.20 cc	2.10 ÷ 2.30	210	250	17050007.014	49.2
26	2.60 cc	2.50 ÷ 2.70	210	250	17050008.014	50.7
32	3.20 cc	3.10 ÷ 3.32	210	250	17050009.014	60.9
38	3.80 cc	3.60 ÷ 3.99	210	250	17050010.014	63.1
43	4.30 cc	4.00 ÷ 4,35	210	250	17050011.014	63.4

P2 = Intermittent operating pressure
 P3 = Intermittent peak pressure (20 sec. max)

P 1 (2) ** / * Pumps group 1 with start valve - Performance level 2 (1)

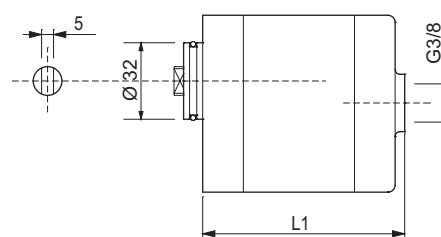

**	Nominal displacement	Tolerance on geometric displacement	P2 bar	P3 bar	Code complete kit	L1 mm
09	0.90 cc	0.83 ÷ 0.95	210	250	17050096.014	42.2
12	1.20 cc	1.10 ÷ 1.30	210	250	17050041.014	43.5
17	1.70 cc	1.50 ÷ 1.70	210	250	17050042.014	45.3
22	2.20 cc	2.10 ÷ 2.30	210	250	17050043.014	49.2
26	2.60 cc	2.50 ÷ 2.70	210	250	17050044.014	50.7
32	3.20 cc	3.10 ÷ 3.32	210	250	17050045.014	60.9
38	3.80 cc	3.60 ÷ 3.99	210	250	17050046.014	63.1
43	4.30 cc	4.00 ÷ 4,35	210	250	17050047.014	63.4

1 = Specify Accessory (see table below "Accessories for pumps group 1")
 P2 = Intermittent operating pressure
 P3 = Intermittent peak pressure (20 sec. max)

P 1 (1) ** / * Accessories for pumps group 1

*	Description	Type	Code	Symbol
/A	Single-phase motor start valve - on auxiliary outlet	0.8 ÷ 2.5 l/min	VAM0400L	
/B		> 2.5 ÷ 8.0 l/min	VAM0400M	
/C		> 8.0 ÷ 14 l/min	VAM0400H	
/D	Soft start valve - on auxiliary outlet	hole Ø 0.4 mm	VAMS0404001	

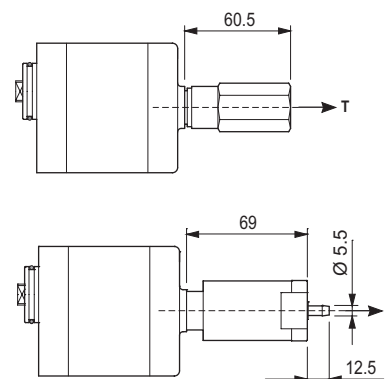

Section IV - Tanks and Tubes kit

Tank (**S** = with tank and tubes kit; **G** = only tubes kit, without tank; **OMIT** if without tank and without tubes kit)
 Capacity liters
 Features (material and construction)
 Mounting position: (**H** = horizontal; **V** = vertical)
 Variants (**00** = standard, no variant) - **OMIT if with tubes kit**
 Orientation - **OMIT if with tubes kit in vertical mounting position**
 End section IV and V

DTR... * ** * (*) ** /* -

**	Liters	*	Dimensions (mm)	Material	(*) Mounting	** Variants	Page	* Orientation
02	1,5	G	∅ 130x140 - L 135	Polyethylene	(H) (V)	00 00	24	/1(std) /2 /3 /4
03	2.5	G	∅ 130x140 - L 235	Polyethylene	(H) (V)	00 00	24	
	2.5	A	∅ 126 - L 235	Sheet steel	(H) (V)	00-01-02 00	21	
04	4	G	∅ 130x140 - L 295	Polyethylene	(H) (V)	00 00	24	
	4	L	∅ 180 - L 210	Polyethylene	(H) (V)	00 00	25	
05	5	C	∅ 200 - L 210	Sheet steel	(H) (V)	00-01-02-03 00	22	
07	7	L	∅ 180 - L 310	Polyethylene	(H) (V)	00 00	26	
08	8	C	∅ 200 - L 306	Sheet steel	(H) (V)	00-03 00	22	
10	10	C	∅ 200 - L 373	Sheet steel	(H) (V)	00 00	22	
	10	L	∅ 180 - L 410	Polyethylene	(H) (V)	00 00	26	
12	12	D	∅ 260 - L 273	Sheet steel	(H) (H)	00 01	23	
			∅ 200 - L 440		(V)	00		

Section IV - Tanks and Tubes kit

* ** * (H) ** * - Tanks Ø 126 - Sheet steel, capacity 2.5 liters - Horizontal mounting

Capacity	Features	Mounting	Variant (1)	L (mm)	Capacity (liters)			Tank (with plug)	Tank fixing kit (screws and O-Ring)
					Nominal	Full	Usable		
2.5	A	(H)	00	235	2.5	2.1	2	1321554	17010093

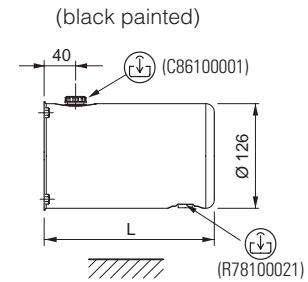

(1) Variant - OMIT if without tank but with tubes kit

(..) spare parts

Other variants

Variant				Tank				Variant				Tank			
2.5	A	(H)	01	1321555	2.5	A	(H)	02	1321553						

--	--

* ** * (V) ** * - Tanks Ø 126 - Sheet steel, capacity 2.5 - Vertical mounting

Capacity	Features	Mounting	Variant (1)	L (mm)	Capacity (liters)			Tank (with plug)	Tank fixing kit (screws and O-Ring)
					Nominal	Full	Usable		
2.5	A	(V)	00	235	2.5	2.1	2	1321764	17010093

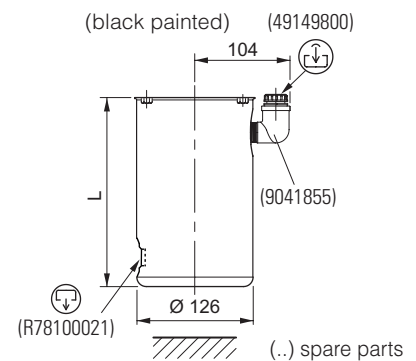

(1) Variant - OMIT if without tank but with tubes kit

(..) spare parts

Other variants

Variant		Tank		Variant		Tank		Variant		Tank	

Section IV - Tanks and Tubes kit

* ** * (H) ** * - Tanks Ø 200 - Sheet steel, capacity 5-8 liters - Horizontal mounting

Capacity	Features	Mounting	Variant (1)	L (mm)	Capacity (liters)			Tank (with plug)	Tank fixing kit (screws and O-Ring)
					Nominal	Full	Usable		
05	C	(H)	00	210	5	5	4.7	1321546	17010093
08				306	8	8.0	7.7	1321539	

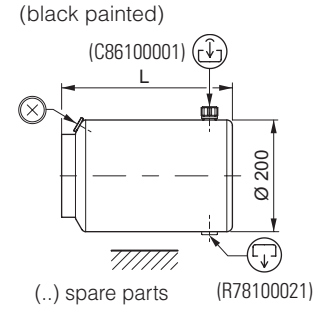

(1) Variant - OMIT if without tank but with tubes kit

Other variants

Variant				Tank																																																																											
05	B	(H)	01	1321542																																																																											
				<table border="1"> <thead> <tr> <th colspan="4">Variant</th> <th colspan="4">Tank</th> </tr> </thead> <tbody> <tr> <td>05</td> <td>B</td> <td>(H)</td> <td>02</td> <td colspan="4">1321544</td> </tr> <tr> <td colspan="4"> </td> <td colspan="4"> <table border="1"> <thead> <tr> <th colspan="4">Variant</th> <th colspan="4">Tank</th> </tr> </thead> <tbody> <tr> <td>05</td> <td>B</td> <td>(H) (V)</td> <td>03</td> <td colspan="4">1321545</td> </tr> <tr> <td colspan="4"> </td> <td colspan="4"> <table border="1"> <thead> <tr> <th colspan="4">Variant</th> <th colspan="4">Tank</th> </tr> </thead> <tbody> <tr> <td>08</td> <td>B</td> <td>(H)</td> <td>01</td> <td colspan="4">1321538</td> </tr> <tr> <td colspan="4"> </td> <td colspan="4"></td> </tr> </tbody> </table> </td> </tr> </tbody> </table> </td></tr></tbody></table>				Variant				Tank				05	B	(H)	02	1321544								<table border="1"> <thead> <tr> <th colspan="4">Variant</th> <th colspan="4">Tank</th> </tr> </thead> <tbody> <tr> <td>05</td> <td>B</td> <td>(H) (V)</td> <td>03</td> <td colspan="4">1321545</td> </tr> <tr> <td colspan="4"> </td> <td colspan="4"> <table border="1"> <thead> <tr> <th colspan="4">Variant</th> <th colspan="4">Tank</th> </tr> </thead> <tbody> <tr> <td>08</td> <td>B</td> <td>(H)</td> <td>01</td> <td colspan="4">1321538</td> </tr> <tr> <td colspan="4"> </td> <td colspan="4"></td> </tr> </tbody> </table> </td> </tr> </tbody> </table>				Variant				Tank				05	B	(H) (V)	03	1321545								<table border="1"> <thead> <tr> <th colspan="4">Variant</th> <th colspan="4">Tank</th> </tr> </thead> <tbody> <tr> <td>08</td> <td>B</td> <td>(H)</td> <td>01</td> <td colspan="4">1321538</td> </tr> <tr> <td colspan="4"> </td> <td colspan="4"></td> </tr> </tbody> </table>				Variant				Tank				08	B	(H)	01	1321538											
Variant				Tank																																																																											
05	B	(H)	02	1321544																																																																											
				<table border="1"> <thead> <tr> <th colspan="4">Variant</th> <th colspan="4">Tank</th> </tr> </thead> <tbody> <tr> <td>05</td> <td>B</td> <td>(H) (V)</td> <td>03</td> <td colspan="4">1321545</td> </tr> <tr> <td colspan="4"> </td> <td colspan="4"> <table border="1"> <thead> <tr> <th colspan="4">Variant</th> <th colspan="4">Tank</th> </tr> </thead> <tbody> <tr> <td>08</td> <td>B</td> <td>(H)</td> <td>01</td> <td colspan="4">1321538</td> </tr> <tr> <td colspan="4"> </td> <td colspan="4"></td> </tr> </tbody> </table> </td> </tr> </tbody> </table>				Variant				Tank				05	B	(H) (V)	03	1321545								<table border="1"> <thead> <tr> <th colspan="4">Variant</th> <th colspan="4">Tank</th> </tr> </thead> <tbody> <tr> <td>08</td> <td>B</td> <td>(H)</td> <td>01</td> <td colspan="4">1321538</td> </tr> <tr> <td colspan="4"> </td> <td colspan="4"></td> </tr> </tbody> </table>				Variant				Tank				08	B	(H)	01	1321538																																			
Variant				Tank																																																																											
05	B	(H) (V)	03	1321545																																																																											
				<table border="1"> <thead> <tr> <th colspan="4">Variant</th> <th colspan="4">Tank</th> </tr> </thead> <tbody> <tr> <td>08</td> <td>B</td> <td>(H)</td> <td>01</td> <td colspan="4">1321538</td> </tr> <tr> <td colspan="4"> </td> <td colspan="4"></td> </tr> </tbody> </table>				Variant				Tank				08	B	(H)	01	1321538																																																											
Variant				Tank																																																																											
08	B	(H)	01	1321538																																																																											

* ** * (V) ** * - Tanks Ø 200 - Sheet steel, capacity 5-8 liters - Vertical mounting

Capacity	Features	Mounting	Variant (1)	L (mm)	Capacity (liters)			Tank (with plug)	Tank fixing kit (screws and O-Ring)
					Nominal	Full	Usable		
05	C	(V)	00	210	5	4.6	4.3	1321543	17010093
08				306	8	7.5	7.1	1321539	

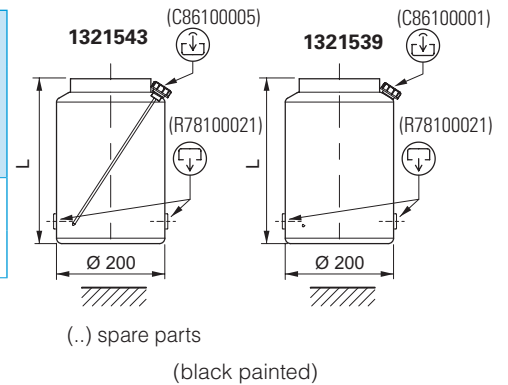

(1) Variant - OMIT if without tank but with tubes kit

Other variants

Variant		Tank		Variant		Tank		Variant		Tank	

Section IV - Tanks and Tubes kit

* ** * (H) ** * - Tanks Ø 200 and Ø 260 - Sheet steel, capacity 12 liters - Horizontal mounting

Capacity	Features	Mounting	Variant (1)	L (mm)	Capacity (liters)			Tank (with plug)	Tank fixing kit (screws and O-Ring)
					Nominal	Full	Usable		
12	D	(H)	00	273	12	10	9.6	1321508	17010093
12	D	(H)	01	440	12	10	9.6	1321534	

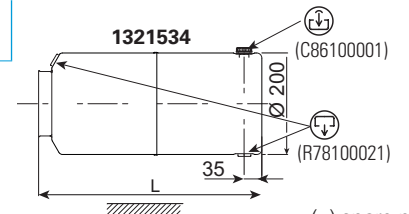
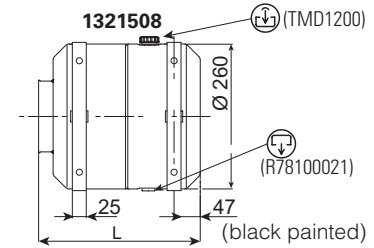

(1) Variant - OMIT if without tank but with tubes kit

Other variants

Variant	Tank	Variant	Tank	Variant	Tank	Variant	Tank

(..) spare parts

* ** * (V) ** * - Tanks Ø 200 - Sheet steel, capacity 12 liters - Vertical mounting

Capacity	Features	Mounting	Variant (1)	L (mm)	Capacity (liters)			Tank (with plug)	Tank fixing kit (screws and O-Ring)
					Nominal	Full	Usable		
12	D	(V)	00	440	12	10	9.6	1321534	17010093

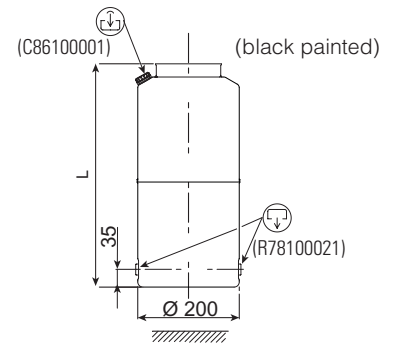

(1) Variant - OMIT if without tank but with tubes kit

(..) spare parts

Other variants

Variant	Tank	Variant	Tank	Variant	Tank	Variant	Tank

Section IV - Tanks and Tubes kit

* ** * (H) ** * - Square polyethylene tanks capacity 1.5-2.5-4 liters - Horizontal mounting

Capacity	Features	Mounting	Variant (1)	L (mm)	Capacity (liters)			Tank (with plug, clamp, nuts)	Tank fixing kit Ø123 (screws and O-Ring)
					Nominal	Full	Usable		
02				135	1.5	1.3	1	1321557	17010087
03	G	(H)	00	235	2.5	2.5	2	1321552	
04				295	4	3.4	2.5	1321550	

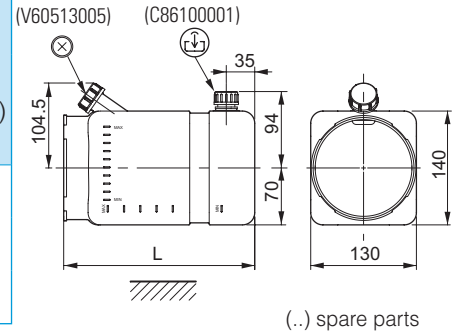

Operating temperature -10°C ÷ +70°C - (1) Variant - OMIT if without tank but with tubes kit

Other variants

Variant			Tank			Variant			Tank			Variant			Tank		

* ** * (V) ** * - Square polyethylene tanks capacity 1.5-2.5-4 liters - Vertical mounting

Capacity	Features	Mounting	Variant (1)	L (mm)	Capacity (liters)			Tank (with plug, clamp, nuts)	Tank fixing kit Ø123 (screws and O-Ring)
					Nominal	Full	Usable		
02				135	1.5	1.1	0.7	1321556	17010087
03	G	(V)	00	235	2.5	2.7	2.3	1321551	
04				295	4	3.5	3.1	1321549	

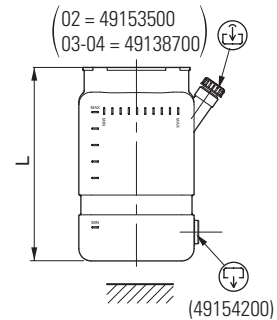

Operating temperature -10°C ÷ +70°C - (1) Variant - OMIT if without tank but with tubes kit

Other variants

Variant			Tank			Variant			Tank			Variant			Tank		

Section IV - Tanks and Tubes kit

* ** * (H) ** * - Square polyethylene tanks capacity 4 liters - Horizontal mounting

Capacity	Features	Mounting	Variant (1)	L (mm)	Capacity (liters)			Tank (with plug, clamp, nuts)	Tank fixing kit Ø123 (screws and O-Ring)
					Nominal	Full	Usable		
04	L	(H)	00	210	4	3.6	3	1321547	17010087

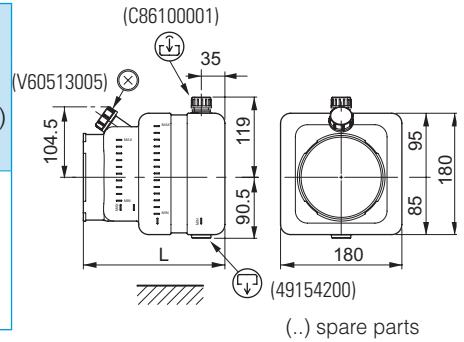

Operating temperature -10°C ÷ +70°C - (1) Variant - OMIT if without tank but with tubes kit

Other variants

Variant			Tank			Variant			Tank			Variant			Tank		

IV

* ** * (V) ** * - Square polyethylene tanks capacity 4 liters - Vertical mounting

Capacity	Features	Mounting	Variant (1)	L (mm)	Capacity (liters)			Tank (with plug, clamp, nuts)	Tank fixing kit Ø123 (screws and O-Ring)
					Nominal	Full	Usable		
04	L	(V)	00	210	4	3.7	3	1321548	17010087

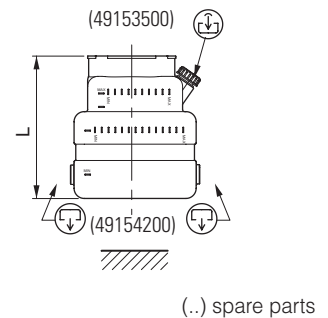

Operating temperature -10°C ÷ +70°C - (1) Variant - OMIT if without tank but with tubes kit

Other variants

Variant			Tank			Variant			Tank			Variant			Tank		

Section IV - Tanks and Tubes kit

* ** * (H) ** * - Square polyethylene tanks capacity 7-10 liters - Horizontal mounting

Capacity	Features	Mounting	Variant (1)	L (mm)	Capacity (liters)			Tank (with plug, clamp, nuts)	Tank fixing kit Ø123 (screws and O-Ring)
					Nominal	Full	Usable		
07	L	(H)	00	310	7	6.7	5.5	1321541	17010087
10				410	10	8.7	7.5	1321537	

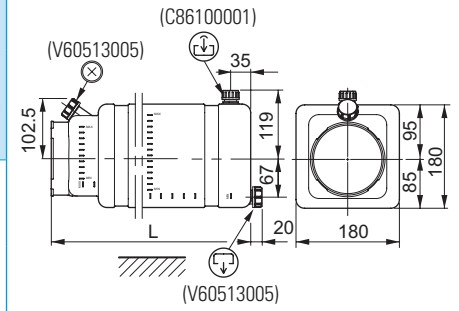

(..) spare parts

Operating temperature -10°C ÷ +70°C - (1) Variant - OMIT if without tank but with tubes kit

IV

* ** * (V) ** * - Square polyethylene tanks capacity 7-10 liters - Vertical mounting

Capacity	Features	Mounting	Variant (1)	L (mm)	Capacity (liters)			Tank (with plug, clamp, nuts)	Tank fixing kit Ø123 (screws and O-Ring)
					Nominal	Full	Usable		
07	L	(V)	00	310	7	6.7	6	1321540	17010087
10				410	10	9.8	9	1321535	

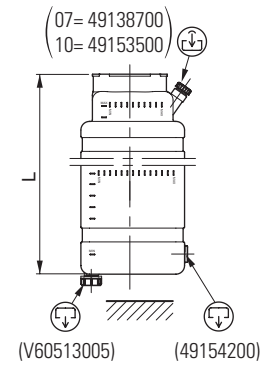

(..) spare parts

Operating temperature -10°C ÷ +70°C - (1) Variant - OMIT if without tank but with tubes kit

Section IV - Tanks and Tubes kit

* ** * (*) ** /* - Tanks orientation according to the mounting position

For tanks			(*)	Mounting position	/* Orientation			
S	**	A C D	(H)	Horizontal	/1 (standard)	/2	/3	/4
					(1)			

For tanks			(*)	Mounting position	/* Orientation			
S	12	D	(H)	Horizontal	/1 (standard)	/2	/3	/4

For tanks			(*)	Mounting position	/* Orientation			
S	**	G L	(H)	Horizontal	/1 (standard)	/2	/3	/4
					(1)			

For tanks			(*)	Mounting position	/* Orientation			
S	**	A C D G L	(V)	Vertical	/1 (standard)	/2	/3	/4
					(2)			

(1) Orientation TO BE USED with blocks

Section V - AC Motors

* Phases		* Poles	* Size	* Power range	Page	(* Version	/* Orientation				
				Power	Voltage						
M	Single-phase	2	L 71	A 0.37 kW	230 Vac 50 Hz	29	(1)	Std			
			L 71	B 0.55 kW	230 Vac 50 Hz	29					
			S 71	A 0.75 kW	230 Vac 50 Hz	31					
			S 71	B 1.10 kW	230 Vac 50 Hz	34					
			M 80	A 0.75 kW	230 Vac 50 Hz	29					
			M 80	B 1.10 kW	230 Vac 50 Hz	29					
			N 90	A 1.50 kW	230 Vac 50 Hz	29					
			N 90	B 2.20 kW	230 Vac 50 Hz	29					
			P 100	A 3.00 kW	230 Vac 50 Hz	29					
		4	L 71	A 0.25 kW	230 Vac 50 Hz	29					
			L 71	B 0.37 kW	230 Vac 50 Hz	29					
			M 80	A 0.55 kW	230 Vac 50 Hz	29					
			M 80	B 0.75 kW	230 Vac 50 Hz	29					
			N 90	A 1.10 kW	230 Vac 50 Hz	29					
			N 90	B 1.50 kW	230 Vac 50 Hz	29					
			P 100	A 2.20 kW	230 Vac 50 Hz	29					
			T	Three-phase	2	R 63			A 0.18 kW	230/400 Vac 50 Hz	30
						R 63			B 0.25 kW	230/400 Vac 50 Hz	30
L 71	A 0.37 kW	230/400 Vac 50 Hz				30					
L 71	B 0.55 kW	230/400 Vac 50 Hz				30					
S 71	A 0.75 kW	230/400 Vac 50 Hz				31					
M 80	A 0.75 kW	230/400 Vac 50 Hz				30					
M 80	B 1.10 kW	230/400 Vac 50 Hz				30					
N 90	A 1.50 kW	230/400 Vac 50 Hz				30					
N 90	B 2.20 kW	230/400 Vac 50 Hz				30					
4	P 100	A 3.00 kW			230/400 Vac 50 Hz	30					
	P 112	B 4.00 kW			230/400 Vac 50 Hz	30					
	R 63	A 0.12 kW			230/400 Vac 50 Hz	30					
	R 63	B 0.18 kW			230/400 Vac 50 Hz	30					
	L 71	A 0.25 kW			230/400 Vac 50 Hz	30					
	L 71	B 0.37 kW			230/400 Vac 50 Hz	30					
	S 71	A 0.75 kW			230/400 Vac 50 Hz	31					
	M 80	A 0.55 kW			230/400 Vac 50 Hz	30					
	M 80	B 0.75 kW			230/400 Vac 50 Hz	30					
N 90	A 1.10 kW	230/400 Vac 50 Hz	30								
N 90	B 1.50 kW	230/400 Vac 50 Hz	30								
P 100	A 2.20 kW	230/400 Vac 50 Hz	30								
P 100	B 3.00 kW	230/400 Vac 50 Hz	30								
P 112	C 4.00 kW	230/400 Vac 50 Hz	30								



DTR M * * * * (*) /* -

Motors supplied with all assembly components (transmission kit, coupling, etc).



M * * * * (*)

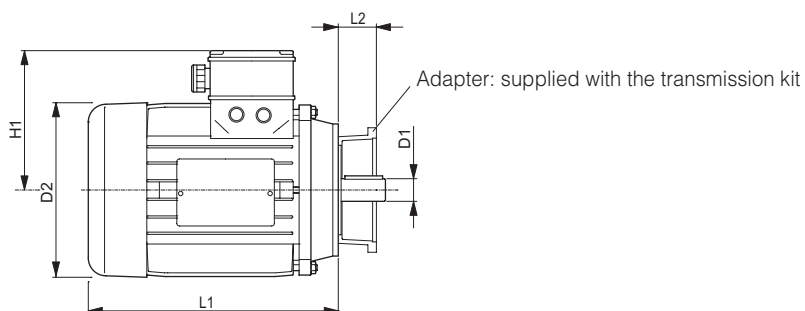

Single-phase motors 2-4 Poles - 230 Vac 50Hz - Version B14

M	*	*	*	*	(*)	Phases	Poles	Size	D1 (°)	D2 (°)	H1 (°)	L1 (°)	Power range					Cable gland metric thred	Adapter			Single Motor	Transmission kit (for pump)
													Power kW	Voltage	IP	IC	S1		Code	Screw UNI 5931	L2		
M	M	2	L	A	(1)	2	2	71	14	148	115	208	0.37	230 Vac 50 Hz	54	F	Si	20-25	61000700	M6x20	19.5	9045596	KIT08019.012
M	M	2	L	B	(1)	2	2	71	14	148	115	208	0.55	230 Vac 50 Hz	54	F	Si	20-25	61000700	M6x20	19.5	9045597	
M	M	2	M	A	(1)	2	2	80	19	170	126	234	0.75	230 Vac 50 Hz	54	F	Si	20-25	61000800	M6x20	30.4	9045598	KIT08019.014
M	M	2	M	B	(1)	2	2	80	19	170	126	234	1.10	230 Vac 50 Hz	54	F	Si	20-25	61000800	M6x20	30.4	9045599	
M	M	2	N	A	(1)	2	2	90	24	185	142	247	1.50	230 Vac 50 Hz	54	F	Si	20-25	61000900	M8x21	40.4	9045600	KIT08019.016
M	M	2	N	B	(1)	2	2	90	24	185	142	272	2.20	230 Vac 50 Hz	54	F	Si	20-25	61000900	M8x21	40.4	9045601	
M	M	2	P	A	(1)	2	2	100	28	210	155	310	3.00	230 Vac 50 Hz	54	F	Si	25-32	61001000	M8x28	75	9045602	KIT08019.046
M	M	4	L	A	(1)	2	4	71	14	148	115	208	0.25	230 Vac 50 Hz	54	F	Si	20-25	61000700	M6x20	19.5	9045589	KIT08019.012
M	M	4	L	B	(1)	2	4	71	14	148	115	208	0.37	230 Vac 50 Hz	54	F	Si	20-25	61000700	M6x20	19.5	9045590	
M	M	4	M	A	(1)	2	4	80	19	170	126	234	0.55	230 Vac 50 Hz	54	F	Si	20-25	61000800	M6x20	30.4	9045591	KIT08019.014
M	M	4	M	B	(1)	2	4	80	19	170	126	234	0.75	230 Vac 50 Hz	54	F	Si	20-25	61000800	M6x20	30.4	9045592	
M	M	4	N	A	(1)	2	4	90	24	185	142	247	1.10	230 Vac 50 Hz	54	F	Si	20-25	61000900	M8x21	40.4	9045593	KIT08019.016
M	M	4	N	B	(1)	2	4	90	24	185	142	272	1.50	230 Vac 50 Hz	54	F	Si	20-25	61000900	M8x21	40.4	9045594	
M	M	4	P	A	(1)	2	4	100	28	210	155	310	2.20	230 Vac 50 Hz	54	F	Si	25-32	61001000	M8x28	75	9045595	KIT08019.046



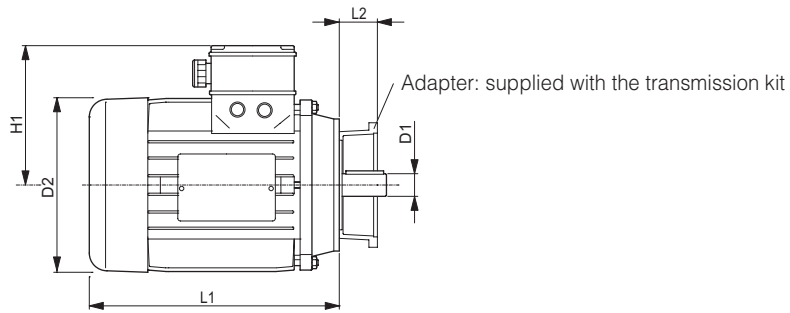

Three-phase motors 2-4 Poles - 230/400 Vac 50Hz - Version B14

Phases	Poles	Size	D1 (•)	D2 (•)	H1 (•)	L1 (•)	Power range					Cable gland metric thred	Adapter			Single Motor	Transmission kit (for pump)	
							Power kW	Voltage	IP	IC	S3		Code	Screw UNI 5931	L2			
M T 2 R A (1)	3	2	63	11	125	95	189	0.18	230/400 Vac 50 Hz	54	F	60%	16-20	61004300	M5x16	19.5	9045557	KIT08019.010
M T 2 R B (1)	3	2	63	11	125	95	189	0.25	230/400 Vac 50 Hz	54	F	60%	16-20	61004300	M5x16	19.5	9045558	
M T 2 L A (1)	3	2	71	14	148	115	208	0.37	230/400 Vac 50 Hz	54	F	60%	20-25	61000700	M6x20	19.5	9045559	KIT08019.012
M T 2 L B (1)	3	2	71	14	148	115	208	0.55	230/400 Vac 50 Hz	54	F	60%	20-25	61000700	M6x20	19.5	9045560	
M T 2 M A (1)	3	2	80	19	170	126	234	0.75	230/400 Vac 50 Hz	54	F	60%	20-25	61000800	M6x20	30.4	9045527	KIT08019.014
M T 2 M B (1)	3	2	80	19	170	126	234	1.10	230/400 Vac 50 Hz	54	F	60%	20-25	61000800	M6x20	30.4	9045561	
M T 2 N A (1)	3	2	90	24	185	142	247	1.50	230/400 Vac 50 Hz	54	F	60%	20-25	61000900	M8x21	40.4	9045562	KIT08019.016
M T 2 N B (1)	3	2	90	24	185	142	272	2.20	230/400 Vac 50 Hz	54	F	60%	20-25	61000900	M8x21	40.4	9045563	
M T 2 P A (1)	3	2	100	28	210	155	310	3.00	230/400 Vac 50 Hz	54	F	60%	25-32	61001000	M8x28	75	9045564	KIT08019.046
M T 2 P B (1)	3	2	112	28	225	182	325	4.00	230/400 Vac 50 Hz	54	F	60%	25-32	61001000	M8x28	75	9045565	
M T 4 R A (1)	3	4	63	11	125	95	189	0.12	230/400 Vac 50 Hz	54	F	60%	16-20	61004300	M5x16	19.5	9045574	KIT08019.010
M T 4 R B (1)	3	4	63	11	125	95	189	0.18	230/400 Vac 50 Hz	54	F	60%	16-20	61004300	M5x16	19.5	9045575	
M T 4 L A (1)	3	4	71	14	148	115	208	0.25	230/400 Vac 50 Hz	54	F	60%	20-25	61000700	M6x20	19.5	9045576	KIT08019.012
M T 4 L B (1)	3	4	71	14	148	115	208	0.37	230/400 Vac 50 Hz	54	F	60%	20-25	61000700	M6x20	19.5	9045577	
M T 4 M A (1)	3	4	80	19	170	126	234	0.55	230/400 Vac 50 Hz	54	F	60%	20-25	61000800	M6x20	30.4	9045578	KIT08019.014
M T 4 M B (1)	3	4	80	19	170	126	234	0.75	230/400 Vac 50 Hz	54	F	60%	20-25	61000800	M6x20	30.4	9045579	
M T 4 N A (1)	3	4	90	24	185	142	247	1.10	230/400 Vac 50 Hz	54	F	60%	20-25	61000900	M8x21	40.4	9045580	KIT08019.016
M T 4 N B (1)	3	4	90	24	185	142	272	1.50	230/400 Vac 50 Hz	54	F	60%	20-25	61000900	M8x21	40.4	9045581	
M T 4 P A (1)	3	4	100	28	210	155	310	2.20	230/400 Vac 50 Hz	54	F	60%	25-32	61001000	M8x28	75	9045583	KIT08019.046
M T 4 P B (1)	3	4	100	28	210	155	310	3.00	230/400 Vac 50 Hz	54	F	60%	25-32	61001000	M8x28	75	9045584	
M T 4 P C (1)	3	4	112	28	225	182	325	4.00	230/400 Vac 50 Hz	54	F	60%	25-32	61001000	M8x28	75	9045585	

(•) = Approximate dimensions



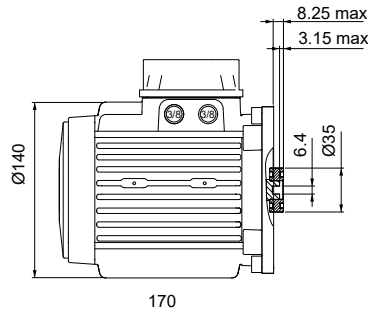

Three-phase motors 2-4 Poles - 230/400 Vac 50Hz - Direct fixing

Phases	Poles	Size	Power range				Cable gland metric thred	Single Motor	Transmission kit	Note							
			Power kW	Voltage	IP	IC					Service						
M	T	2	S	A	(1)	3	2	71	0.75	230/400 Vac 50 Hz	54	F	Light-duty	20	9044919	KIT09008.000	Without fan
M	T	2	S	B	(1)	3	2	71	1.10	230/400 Vac 50 Hz	54	F	Light-duty	20	9044406	KIT09008.000	Without fan
M	T	4	S	A	(1)	3	4	71	0.75	230/400 Vac 50 Hz	54	F	Light-duty	20	9044411	KIT09008.000	Without fan



IP protection level becomes effective after installation on power pack.

M * * * * (*) / * - Motor orientation

Connector box position on power pack.

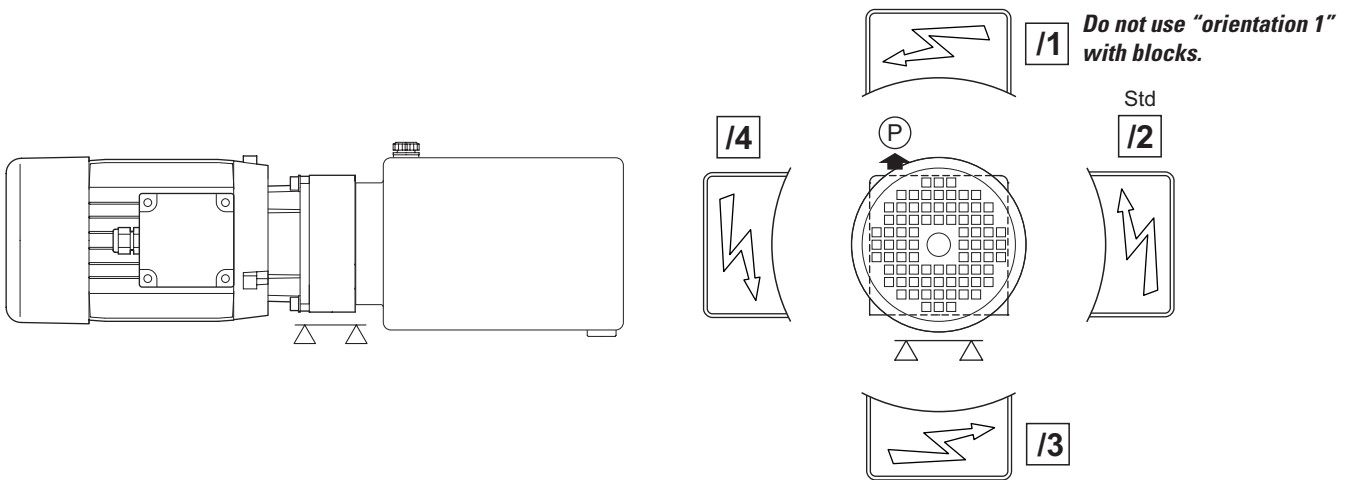

Section VI - Transmission kit AC motors

Transmission kit (only for motors on the catalog)
 Type
 End section VII

Specify the transmission kit whether you requested the joint and accessories assembly (without motor).

DTR..... **T** ****** -

**	Transmission kit						For AC motors		Page
	Code	Pump	L	Ø	L1	Z	Ref.	Size	
1R	KIT08019.010	Gr. 1	19.5	20	30	42.8	R	63 (B14)	29 30

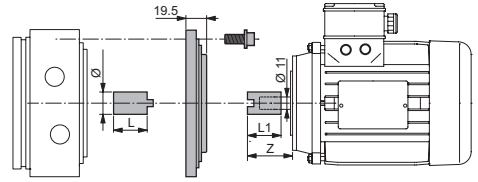

**	Transmission kit						For AC motors		Page
	Code	Pump	L	Ø	L1	Z	Ref.	Size	
1L	KIT08019.012	Gr. 1	19.5	20	26.5	42	L	71 (B14)	29 30

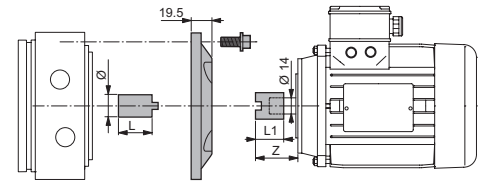

**	Transmission kit						For AC motors		Page
	Code	Pump	L	Ø	L1	Z	Ref.	Size	
1M	KIT08019.014	Gr. 1	19.5	20	38	53	M	80 (B14)	29 30

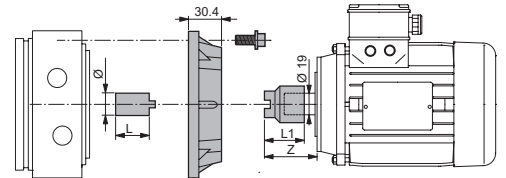

**	Transmission kit						For AC motors		Page
	Code	Pump	L	Ø	L1	Z	Ref.	Size	
1N	KIT08019.016	Gr. 1	19.5	20	45.5	63	N	90 (B14)	29 30

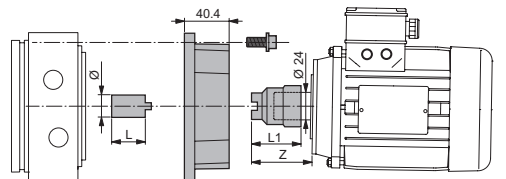

**	Transmission kit						For AC motors		Page
	Code	Pump	L	Ø	L1	Z	Ref.	Size	
1P	KIT08019.046	Gr. 1	36.3	20	57	81.5	P	100-112 (B14)	29 30

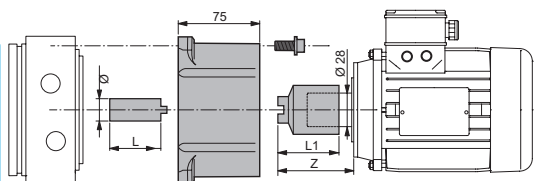

**	Transmission kit				For AC motors		Page
	Code	Pump	L	Ø	Ref.	Size	
1S	KIT09008.000	Gr. 1	37.9	14	S	71 (direct fixing)	31

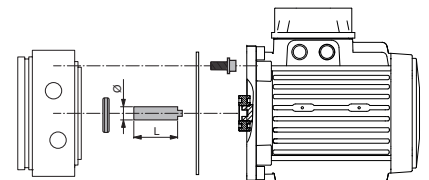

“Z” : dimension of the coupling side motor

Section VII - Accessories (optional)

Accessories (optional)
First accessory
Second accessory

DTR **R** * *

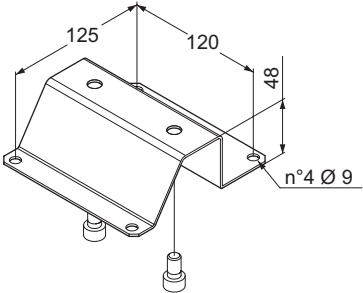
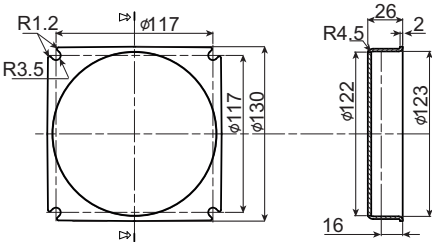
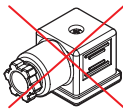
* Description	Drawing	Code	Note
B Non-removable red plastic plug for pressure relief valve (unassembled)		Plug: 60309200	
D High foot, (galvanized sheet steel) thickness 2 mm (unassembled)		Kit (foot and screws): 17010053	All motors are compatible except orientation / 3 Tanks compatible (except for orientation / 3) S**A S**B S**C S**D S**F S**G S**L
E Collar in welded sheet steel, thickness 2 mm (unassembled)		Collar: F80000001 Tank fixing kit (screws and O-Ring): 17010083	
F Without valves connectors			

Example with DTR endhead

DTR	EB1(100)	DAAF(100)	BDBAB	GDDAB	HDDAB	00
-----	----------	-----------	-------	-------	-------	----

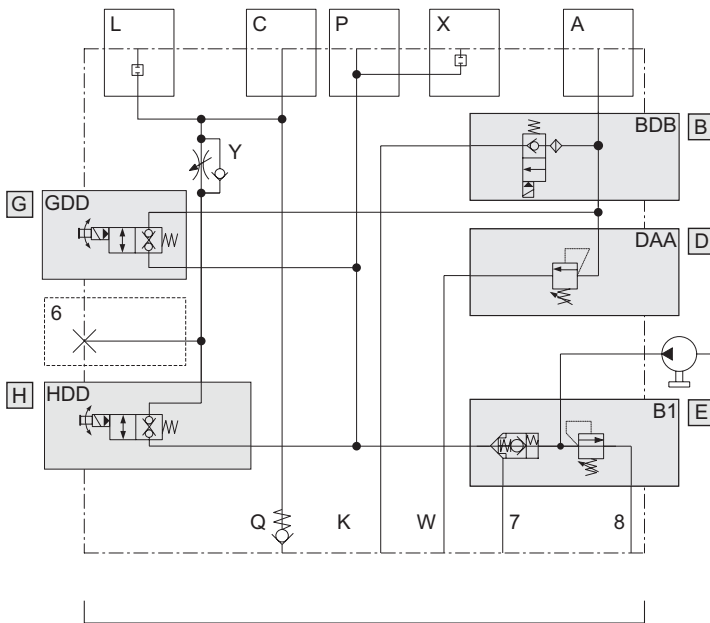

Cavity	Code	Description	Page
	R		10
E	EB1(100)	Pressure relief valve with logic valve (35 ÷ 110 bar) with screw and detachable closing, special setting 100 bar	11
D	DAAF(150)	Pressure relief valve with short screw adjustment and detachable closing, special setting 150 bar	12
B	BDBAB	Piloted solenoid valve normally closed, with rotary emergency. Voltage 24 VDC	13
G	GDDAB	Direct operated solenoid valve normally closed, with button emergency. Voltage 24 VDC	14
H	HDDAB	Direct operated solenoid valve normally closed, with button emergency. Voltage 24 VDC	16
-	-	End section	—

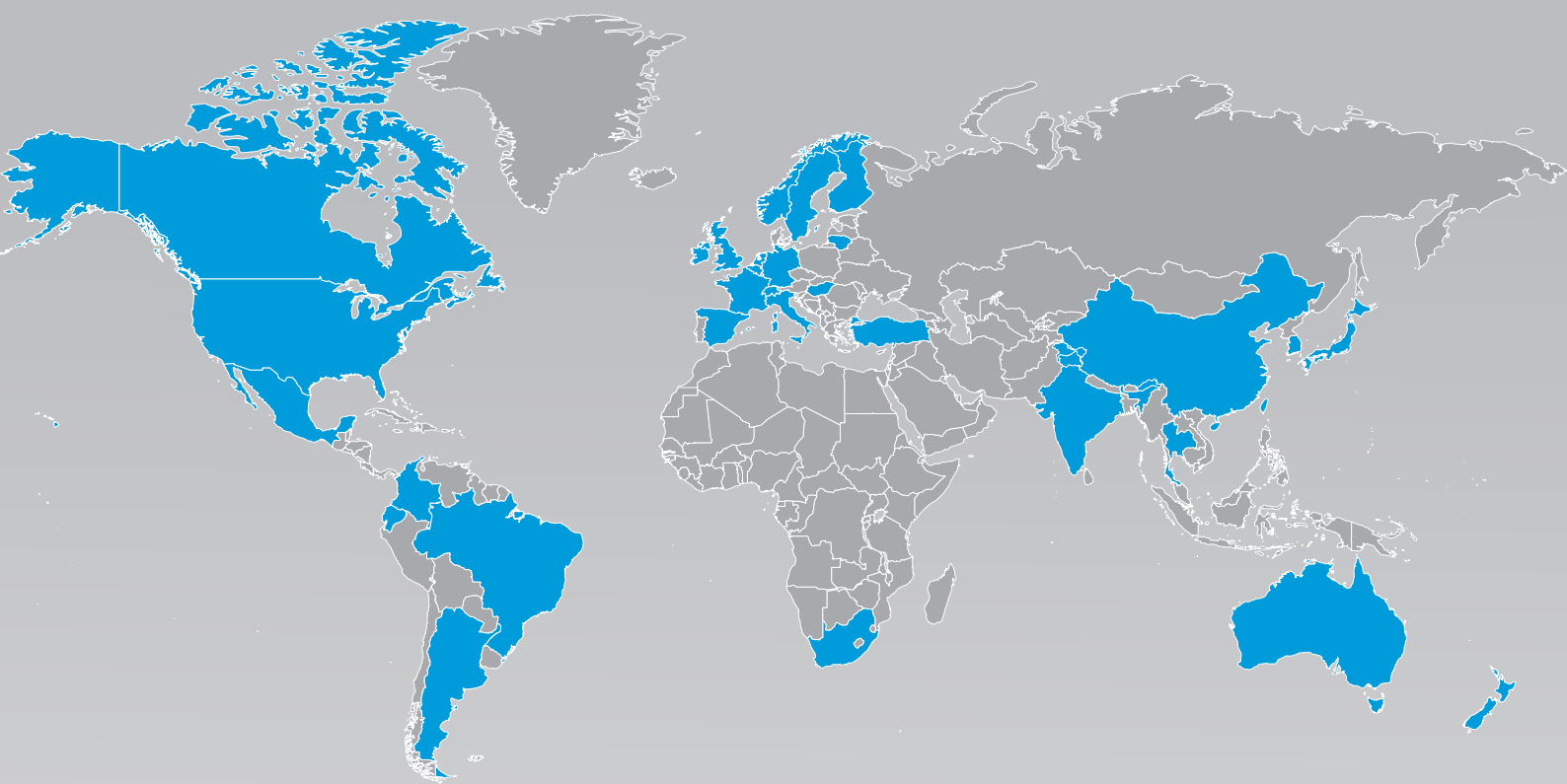

Technologies Customized to Every Part of the Globe

With a presence in 31 countries, Dana Incorporated boasts more than 150 engineering, manufacturing, and distribution facilities. Our worldwide network of local service centers provides assurance that each customer will benefit from the local proximity and responsiveness.

About Dana Incorporated

Dana is an integral partner for virtually every major vehicle and engine manufacturer worldwide. We are a leading supplier of drivetrain, sealing, and thermal technologies to the global automotive, commercial-vehicle, and off-highway markets. Founded in 1904, we employ thousands of people across six continents.



About Dana Off-Highway Drive and Motion Technologies

Dana delivers fully optimized Spicer® drivetrain and Brevini® motion systems to customers in construction, agriculture, material-handling, mining, and industrial markets. We bring our global expertise to the local level with technologies customized to individual requirements through a network of strategically located technology centers, manufacturing locations, and distribution facilities.

Learn more about Dana's drivetrain and motion systems at dana.com/offhighway.

Dana-Industrial.com

Application Policy

Capacity ratings, features, and specifications vary depending upon the model and type of service. Application approvals must be obtained from Dana; contact your representative for application approval. We reserve the right to change or modify our product specifications, configurations, or dimensions at any time without notice.



BREVINI®

Motion Systems