

Damping Technology

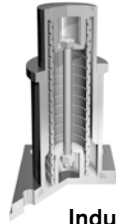

Friction Springs



Industrial buffer

EN 08.2019

Product Paper & Tech Paper



Welcome



Machine Building



Aerospace



Process



Movement



Energy



Extraction



Your system supplier for every aspect of power transmission

We say what we mean and mean what we say.

We see things from our customers' perspective.

We are considerate of our employees and their families as well as of our environment and society.



RINGFEDER POWER TRANSMISSION is the global market leader in the niche markets of drive technology and is well regarded for its customer-specific, application-oriented solutions that ensure excellent and failure-free operation for its clients. We offer locking devices, damping technology and couplings for OEMs but also for the final customer under our strong brand name RINGFEDER®.

We do not only provide competent advice to our customers on the basis of our 90 years of experience but also develop innovative ideas in cooperation with them. This is part of our aspiration to be a **Partner for Performance**.

Around the power transmission we promise

- Excellent know-how for our challenging customers
- Best cost-benefit ratio
- Short reaction times and a high product availability





Know-how

Over 90 years of expertise.

On-site worldwide

We are there for you. Anytime, anywhere.

Your expert partner

From development to the finished product.

Customer

Value

Online calculation program

Always find the right solution.

Your projects are our drive

Know-how: Over 90 years of expertise.

Rely on decades of engineering expertise from the inventor of the friction spring. As an expert in drive and damping technology, we are your reliable partner wherever forces are at work. Be it the permanent transfer of very high torques due to non-positive or positive connections or the absorption and trapping of extreme energies to protect expensive constructions.

Your expert partner: From development to the finished product.

We accompany you through to the successful completion of your project. Beginning with the development phase of your project, we offer our know-how and professional solutions. By working together with global market leaders and as an international supplier of outstanding products and special solutions, we are a reliable partner for you.

Online calculation program: Always find the right solution.

In response to the complex requirements involved in the correct selection and design of the required products under practical conditions, we have developed our online calculation program. Engineers and experts are able to calculate transferable torques and other important values, taking into account various parameters. Visit our website www.ringfeder.com!

On-site worldwide: We are there for you. Anytime, anywhere.

With our locations in Germany, the Czech Republic, the USA, Brazil, China and India as well as a worldwide service and partner network, we are there for you around the clock. This ensures our support for the successful completion of your projects at any time.

RINGFEDER®

Damping Technology

Introduction

Protecting people, conserving machines – modern damping products are indispensable safety parts inside all technologies when sudden occurring kinetic energy has to be absorbed. In the crash absorption, with machine tools or production plants, impact damping units dissipate the energy of an unwanted collision into targeted deformation energy and can so save lives or prevent precious technology from destruction and respectively extend their durability.

For almost 100 years we are experts, when moved masses have to be slowed down fast, safe and precise. We develop, manufacture and supply top products for damping technology – as standard products or precision work or customized.

Friction Springs

RINGFEDER® Friction Springs are employed in the engineering sector when high kinetic energies must be absorbed or when springs of relatively compact dimensions are required for high forces.



Industrial buffer

RINGFEDER® Friction Springs can also be supplied in customer-specific buffer versions.

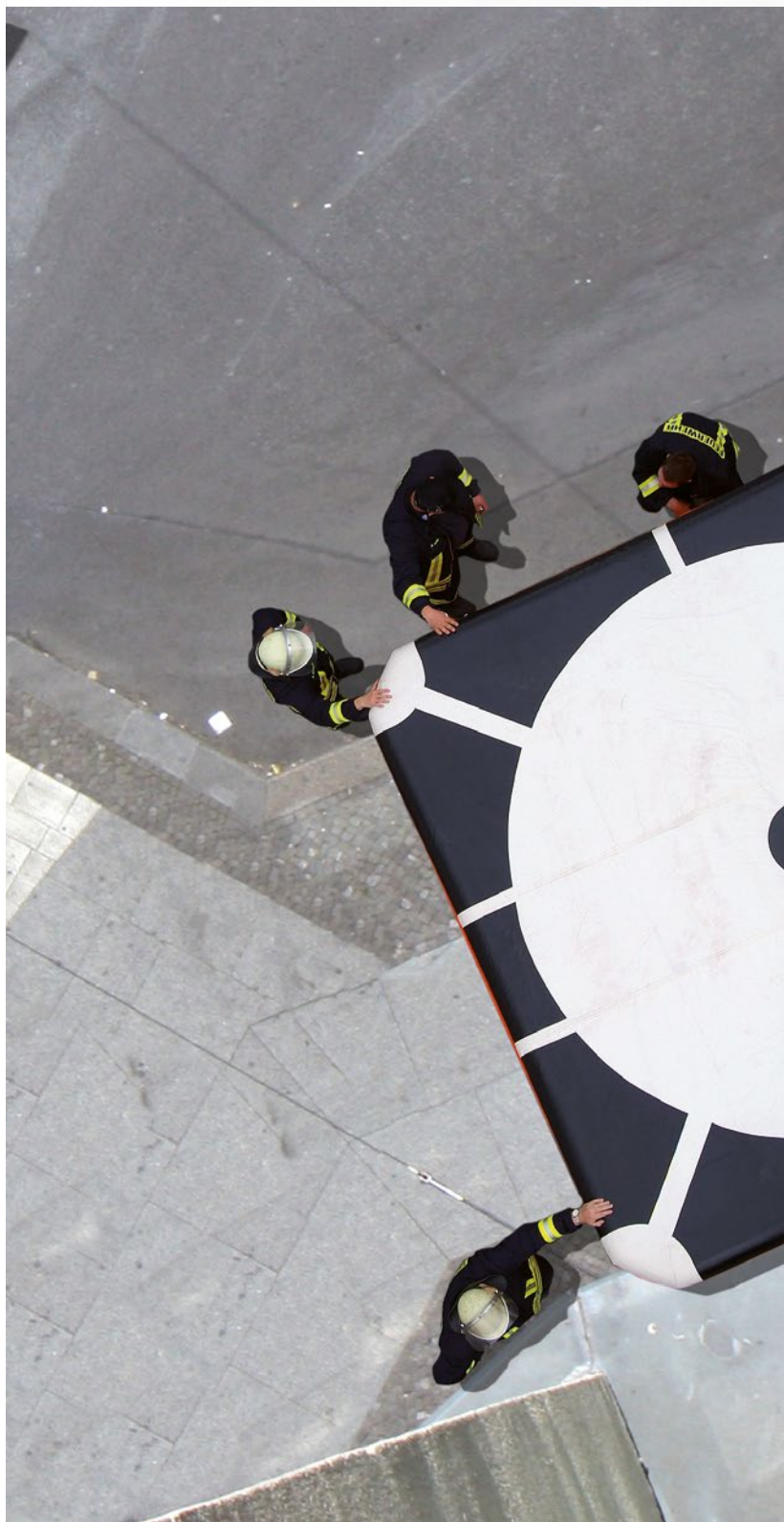
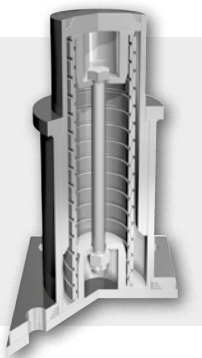



RINGFEDER®

Friction Springs

Features

Features of RINGFEDER® Friction Springs

RINGFEDER® Friction Springs have multitude features in opposite to other damping systems:

- High spring work combined with low weight and volume
- High damping potential
- Overload-safe in blocked position
- Independent of loading rate
- Diagram independent of temperature
- Maintenance-free
- Variable structure of the RINGFEDER® friction spring
- Can be designed individually for the use case
- Parallel and series arrangement

High damping potential

The damping of RINGFEDER® Friction Springs is standard with 66% wherewith the energy will be soon absorbed and resonances complete disabled. Variations in damping between 33% and 66% are possible by using other lubricants specific to the customer and application.

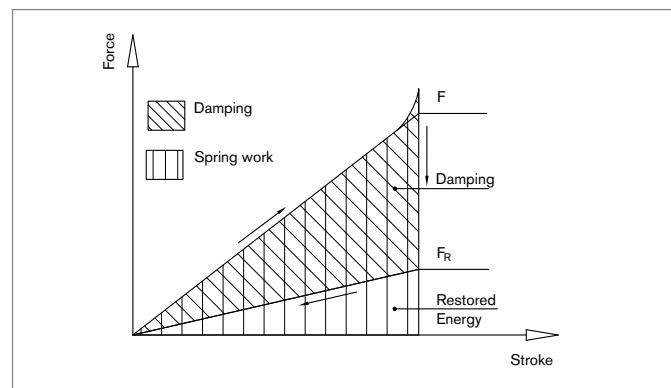

Damping and spring work

High spring work combined with low weight and volume

As RINGFEDER® Friction Springs completely utilise the material a minimum of dimensions and weight are possible. The decisive parameter here is therefore the spring work.

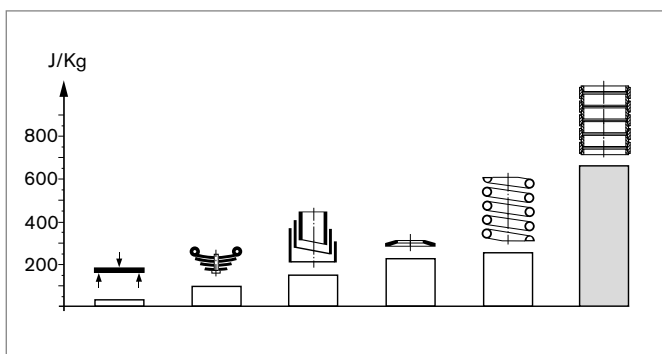

Weight utilization η of various springs

Overload-safe in blocked position

RINGFEDER® Friction Springs are generally designed to “block”, so it is therefore ensured that the admissible stresses cannot be exceeded and the RINGFEDER® Friction Springs will not be damaged.

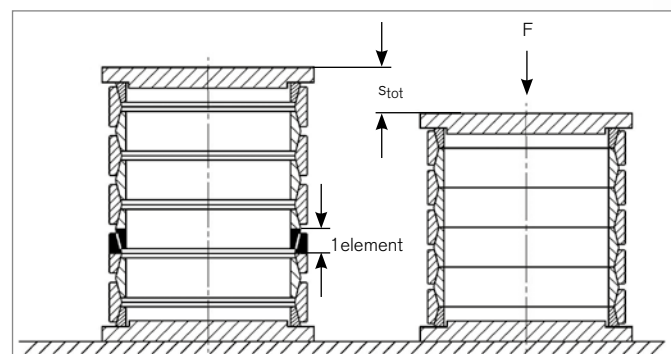

Overload protection

Disclaimer of liability

All technical details and notes are non-binding and cannot be used as a basis for legal claims. The user is obligated to determine whether the represented products meet his requirements.

We reserve the right carry out modifications at any time in the interests of technical progress.

RINGFEDER® Friction Spring design

Independent of loading rate

The force-stroke diagram of the RINGFEDER® Friction Spring applies for all operating conditions. In contrast to other damping systems, RINGFEDER® Friction Springs provide full spring work and damping effects even, when the load is applied extremely slowly or quickly.

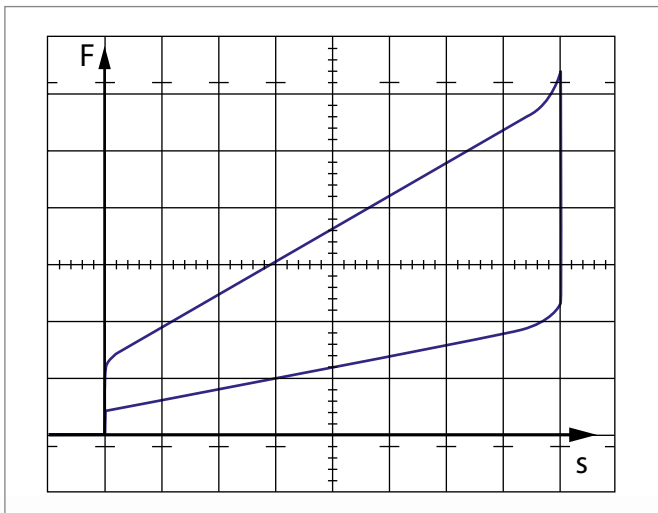

Dynamic force-stroke diagram of a pretensioned RINGFEDER® Friction Spring

Diagram independent of temperature

With hydraulic dampers and springs made of synthetic material, the force-stroke diagram will be influenced by temperature fluctuations and inherent temperature rises. The characteristic curve of the RINGFEDER® Friction Spring, however remain independent of these factors and can be used in the temperature range of -20 °C to +60 °C without the curve changing appreciably, as the inherent temperature rises of the spring due to the dampening effect have been taken into account. Please contact us for applications outside the named temperature range because changes will need to be made to the lubricants (-73 °C to +200 °C possible).

Maintenance-free

Generally during operation **no relubrication is required**. The use of other lubricants can even lead to breakdowns.

A RINGFEDER® friction spring comprising **e** elements generally concludes with semi-rings. Its unclamped length L_0 is then (the values h_e , s_e , W_e that are necessary for the calculation can be found in the table on p. 12):

$$L_0 = e \cdot h_e$$

The total spring stroke can be calculated according to the equal:

$$s = e \cdot s_e$$

When eliminating the pretensioning force the spring work is given by:

$$W = e \cdot W_e$$

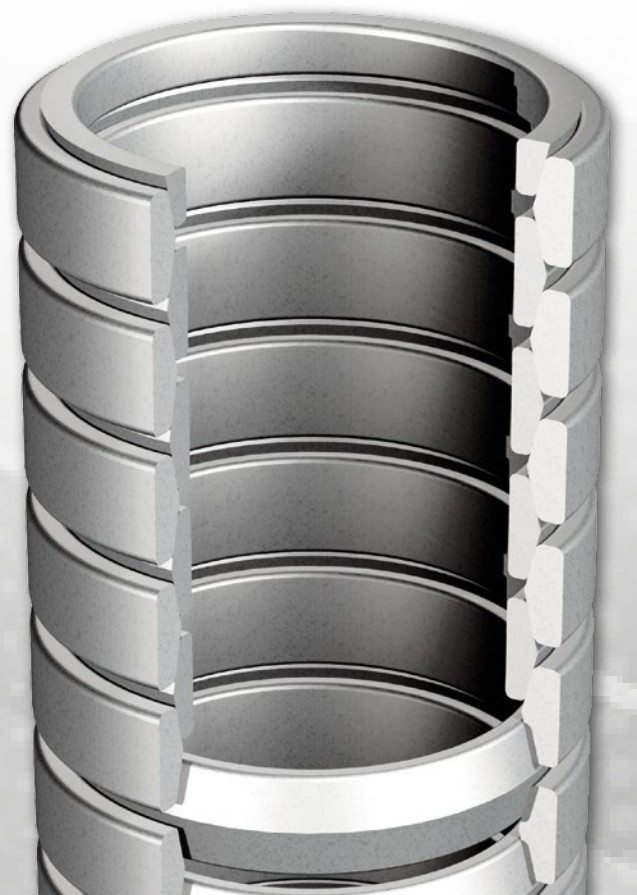

Versatility in design

As well as the standard RINGFEDER® Friction Spring range (see table on page 12) we can offer special solutions based on your specific application. The graph (to the right) shows the ratio of outer diameter to spring end force, this can be used to quickly see if an application is possible even though a standard spring is not available. The geometry of the RINGFEDER® Friction Spring allows an optimum utilisation of the available mounting space due to a nested construction, using parallel or series spring arrangements.

Parallel and series arrangement of springs

The geometry of the RINGFEDER® Friction Springs allows an optimum utilisation of the available mounting space due to a nested construction, using parallel and series spring arrangements.

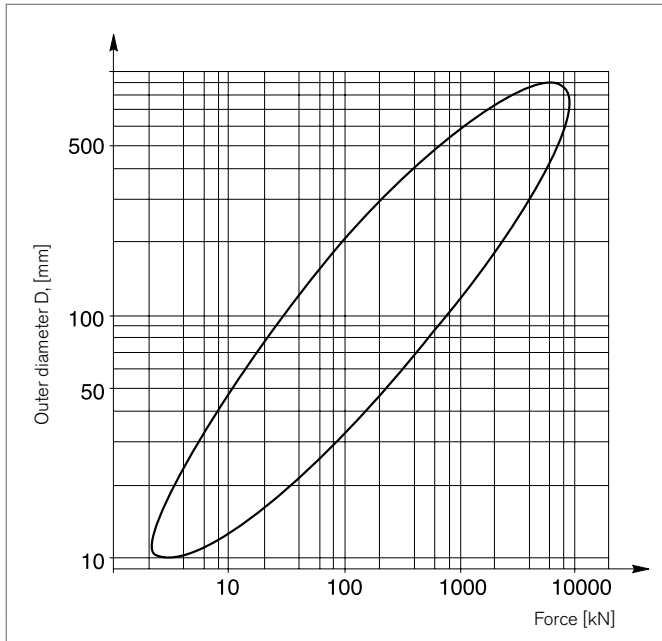

Ratio of outer diameter to spring end force

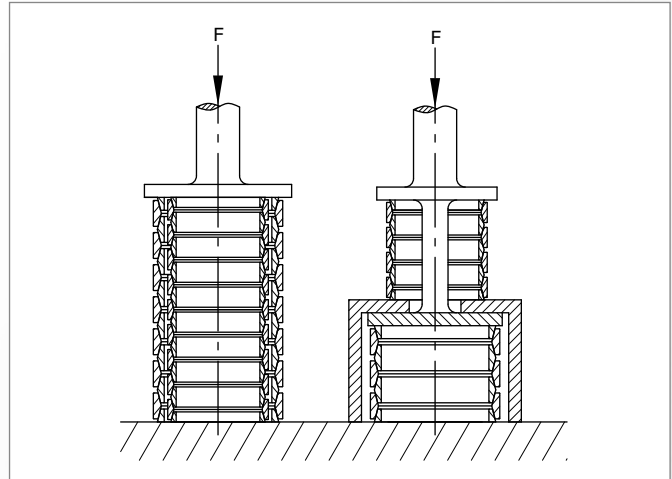

Parallel arrangement for higher forces

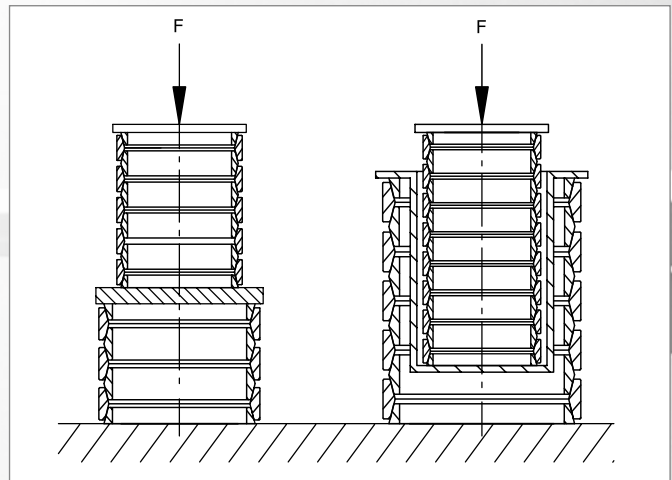

Serial arrangement for more spring travel

In aerospace industry the use of RINGFEDER® Friction Springs is perfect. They are used, for example, in the landing flaps or also in the emergency exit doors.



The low weight, compact construction and the capability of withstanding temperature variations are required for such applications.



Design notes

Force-stroke diagram

During the operation of the friction spring two thirds of the input energy is dissipated as frictional heat. The recoil force F_R at any point on the diagram is approximately equal to one third of the relative

compressive force F . The capacity of the spring is represented by the total area shown below the load curve. The total energy absorption can be calculated by W_e multiplied by the number of elements.

Type	Type old	Diagram				Dimensions			Guide		Gw_e kg
		F kN	s_e mm	W_e Joule	h_e mm	D_1 mm	d_1 mm	$b/2$ mm	D_{2G} mm	d_{2G} mm	
01800	1201	5	0,4	1,0	2,2	18,1	14,4	1,8	18,7	13,9	0,002
02500	1202	9	0,6	2,7	3,1	25,0	20,8	2,5	25,9	20,1	0,004
03200	1203	14	0,8	5,6	4,0	32,0	27,0	3,2	33,1	26,1	0,007
03800	1204	20	0,9	9,0	4,7	38,0	31,7	3,8	39,3	30,6	0,012
04200	1205	26	1,0	13,0	5,2	42,2	34,6	4,2	43,6	33,4	0,018
04800	1206	34	1,1	18,7	5,9	48,2	39,4	4,8	49,8	38,1	0,026
05500	1207	40	1,3	26,0	6,8	55,0	46,0	5,5	56,7	44,5	0,035
06300	1208	54	1,4	37,8	7,7	63,0	51,9	6,3	64,9	50,3	0,056
07000	1209	65	1,6	52,0	8,6	70,0	58,2	7,0	72,1	56,4	0,074
08000	1310	83	1,8	75,0	9,8	80,0	67,0	8,0	83,0	64,0	0,105
09000	1311	100	2,0	100,0	11,0	90,0	75,5	9,0	93,0	73,0	0,145
10000	1312	125	2,2	138,0	12,2	100,0	84,0	10,0	103,0	81,0	0,203
12400	1314	200	2,6	260,0	15,0	124,0	102,0	12,4	128,0	98,0	0,408
13000	1313	160	2,6	208,0	15,0	130,0	111,5	12,4	134,0	108,0	0,376
14000	1315	250	3,0	375,0	17,0	140,0	116,0	14,0	144,0	112,0	0,568
16600 *	1316	350	3,7	648,0	20,0	166,0	134,0	16,0	170,0	130,0	0,869
19600	1318	600	4,4	1320,0	23,4	194,0	155,0	19,0	199,0	150,0	1,676
20000	1317	510	3,9	995,0	22,4	198,0	162,0	18,5	203,0	157,0	1,570
22000	1319	720	4,4	1584,0	26,4	220,0	174,0	22,0	225,0	169,0	2,573
26200	1320	860	4,8	2064,0	25,8	262,0	208,0	21,0	268,0	202,0	3,415
30000	1221	1000	5,8	2900,0	35,8	300,0	250,0	30,0	306,0	245,0	5,510
32000	1222	1200	6,2	3720,0	38,2	320,0	263,0	32,0	326,0	258,0	7,060
35000	1223	1400	6,6	4620,0	41,6	350,0	288,0	35,0	356,0	283,0	9,180
40000	1224	1800	7,6	6840,0	47,6	400,0	330,0	40,0	407,0	324,0	13,560

* For type 1316 a separate stroke limitation has to be provided

Explanations to table

F = Spring end force

s_e = Spring stroke for one element

W_e = Energy absorption of one element

h_e = Length of one element

D_1, d_1 = Outer and inner diameter

$b/2$ = Half length of the ring

D_{2G} = Guiding diameter outside

d_{2G} = Inner guiding diameter

Gw_e = Weight of one element



At this furnace large scrap metal parts are dropped from a high level. By using a several draw gears with a capacity of up to 80.000 Joule/unit, these parts are caught above the cast. This application also requires that the friction springs are constantly subjected to high thermal stresses.

Recommendations for the selection and fitting of RINGFEDER® Friction Springs

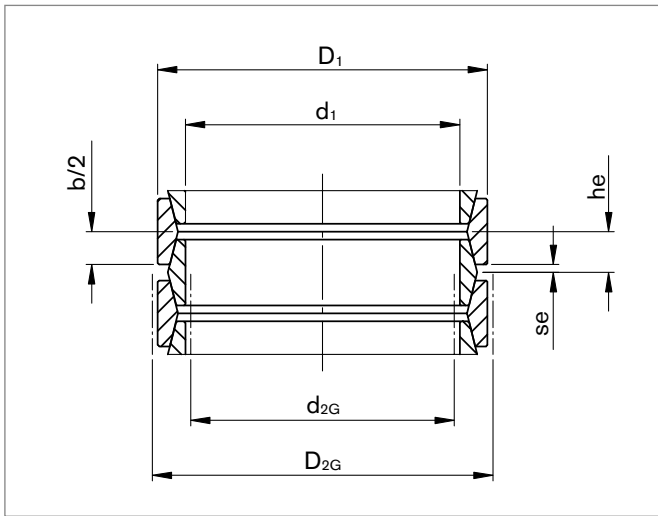

Dimensions RINGFEDER® Friction Springs

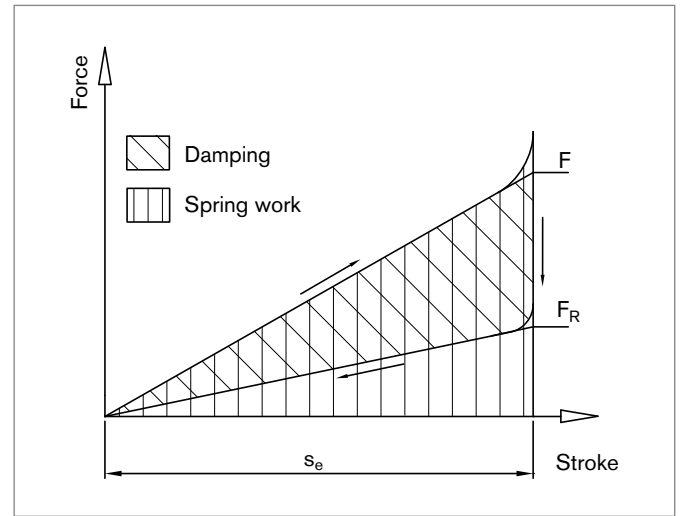

Force-stroke diagram for one element

Pretensioning

RINGFEDER® Friction Springs have to be pretensioned with min. of 5%, preferably 10% of the total spring stroke. In order not to impair the lubricant film, the pretensioning force should not exceed 50%. Exceptions are possible after consultation

Guiding

For RINGFEDER® Friction Springs some form of guiding is necessary (D_2 and d_{2G} in the preceding table). Exceptions apply for short springs with a length $\leq 1,5 D_1$, in this case they need to be loaded between parallel thrust plates.

Lubrication

ONLY the special greases recommended by RINGFEDER® must be used for lubrication purposes, this is because the cone surfaces are under a high contact pressure. Generally, the grease provided with the spring is sufficient. Re-greasing is not required.

Observe the diagram

With buffer springs the available spring work in J, i.e. the area under the loading-curve (above curve), is of interest. If the spring is to be used as a tension device, the recoil curve has to be taken into account (lower curve). Of course, the lower curve can be increased by using a friction reduction lubricant. For this, please let us have your specifications.

Sealing

RINGFEDER® friction springs must be installed protected from dirt and moisture in order not to compromise the lubricant film. Simple plain bearing guides are sufficient. Folding bellows are recommended in cases of heavy soiling and/or dampness development.

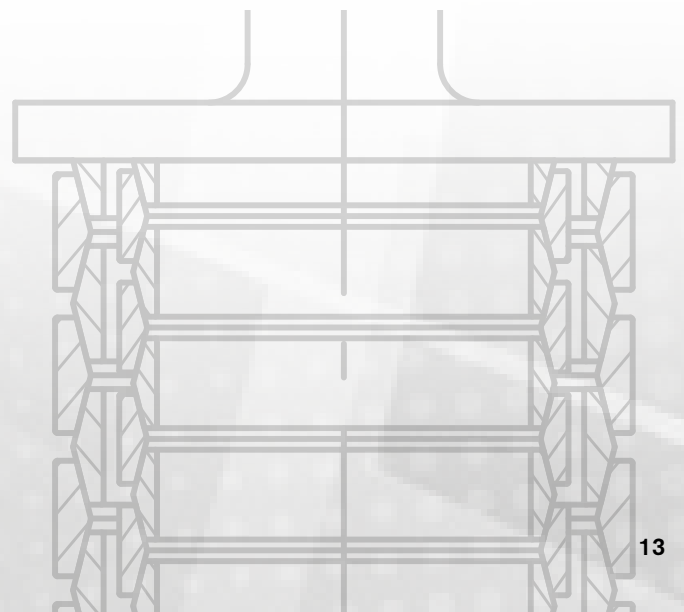

RINGFEDER®

Industrial buffer

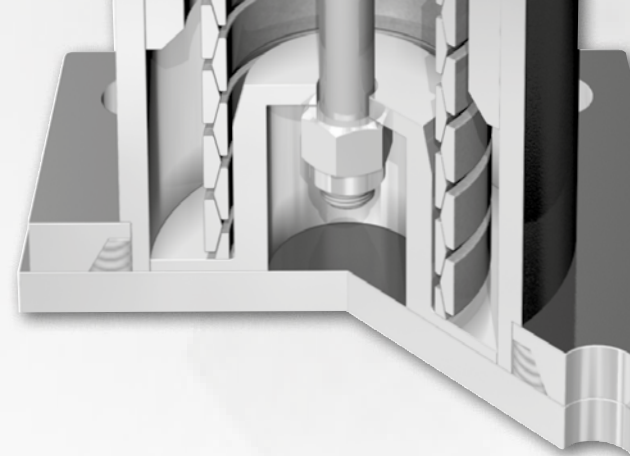

RINGFEDER® Friction Springs can be supplied as complete industrial buffers. A range of buffer types are shown in the table at page 15.

Customer-specific buffer versions are possible, e.g.:

- Variations in flange and/or tappet
- Water cooling

Traction devices and units that work in both traction and compression directions are also possible.



Cross section of industrial buffer



Overload clutch



Traction-compression device

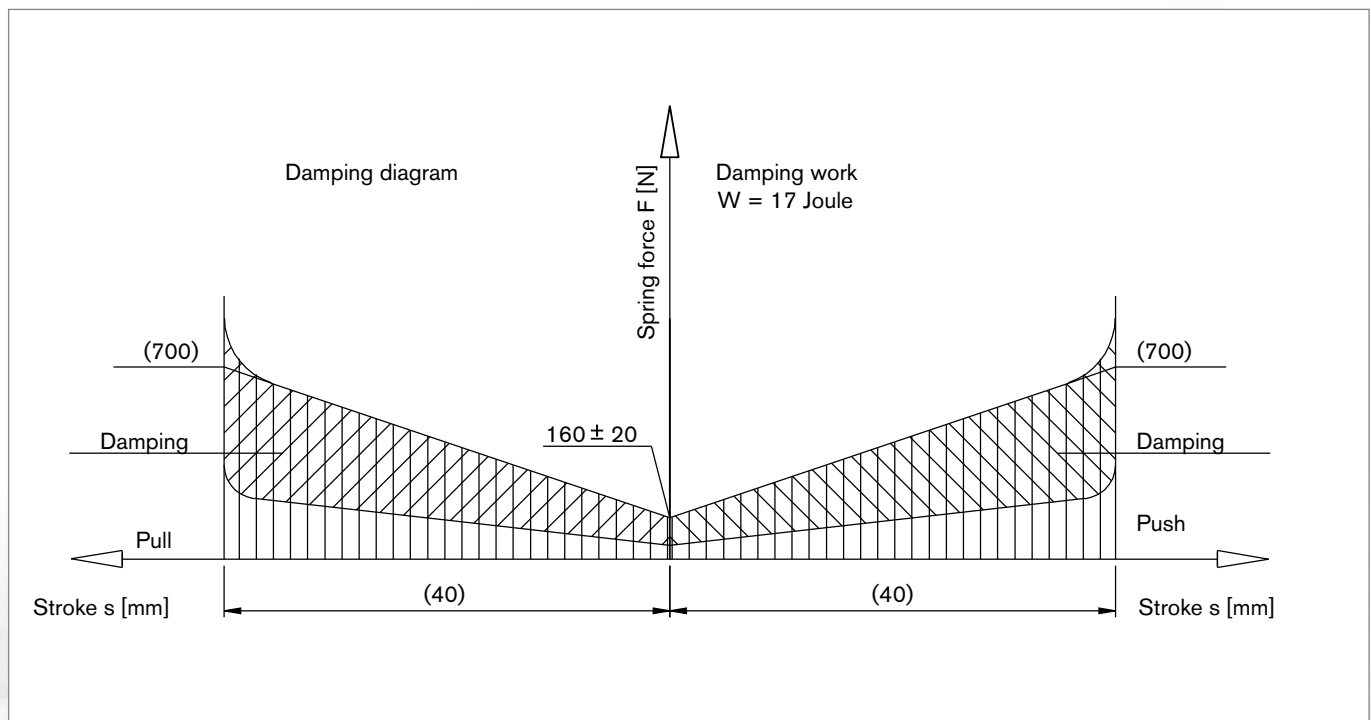

Force-stroke diagram from an traction-compression device

Size	Type	Diagram				Buffer Dimensions									Gw	Fitting			
		F _v	F	s	W	L	l _s	D	D _B	D _C	D _P	F _K	L _N	b		d _b	D _E	t	
		kN		mm	J	mm									kg	mm			
1	06300	6	54	27	820	202	107	112	150	102	80	27	145	10	100	18	104	15	
2				37	1100	262	156							12					
3				55	1640	374	225							17					
4				64	1900	434	293							19					
5				74	2200	494	293							20					
6	08000	7	83	33	1500	230	125	122	200	114	96	27	160	13	110	18	117	15	
7				46	2050	306	170							16					
8				66	2950	428	258							23					
9				79	3550	505	355							26					
10				92	4150	582	360							28					
11	10000	10	125	45	3000	300	165	142	250	133	114	31	185	22	130	23	135	20	
12				61	4100	397	230							26					
13				89	6000	571	350							37					
14				105	7050	667	470							42					
15				121	8150	763	470							45					
16	12400	20	200	51	5600	366	216	178	250	165	142	34	215	39	155	23	167	20	
17				65	7150	454	275							45					
18				102	11200	696	456							64					
19				116	12800	784	574							75					
20				130	14300	872	550							78					
21	16600	10	350	75	13900	500	328	235	370	219	184	46	270	85	200	27	222	25	
22				95	17500	630	450							105					
23				140	25900	880	657							145					
24				165	30500	1040	690							160					
25				190	35000	1200	850							165					
27	19600	20	600	105	32000	620	-	-	-	-	-	-	-	153	-	26	-	-	

Explanations to table

F_v = Preload force
F = Spring end force
s = Spring stroke
W = Spring work
L = Total length
l_s = Submerged length
D = Outer diameter
D_B = Baffle diameter
D_C = Case diameter

D_P = Plunger diameter
F_K = Flange thickness
L_N = Flange width
G_w = Weight
b = Distance between flange bore
d_b = Diameter of through holes
D_E = Installation diameter
t = Wall thickness

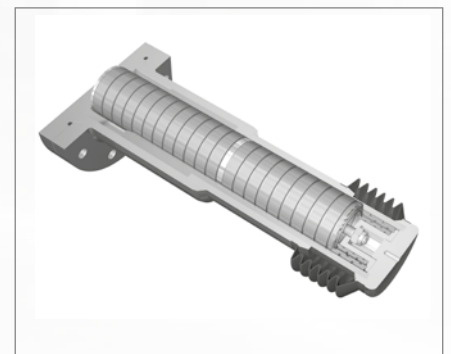

Buffer for gas tank (see page 17)

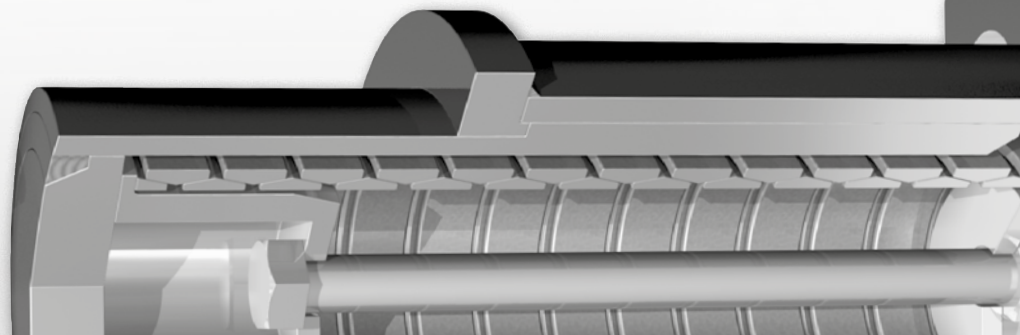

Buffer with RINGFEDER® Friction Springs

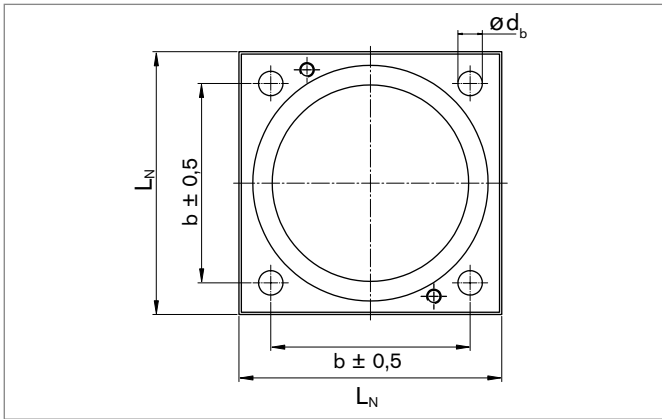

Typical hole pattern

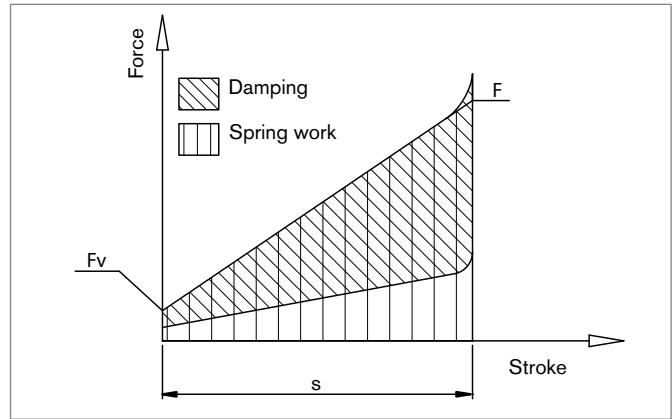

Typical friction spring diagram

The buffer types shown in extracts on the previous page are standard delivered in one of the following 4 designs. These buffers are suitable for operation temperatures from -20 °C to +60 °C. Above

that, modifications allow an extended temperature range from -73 °C to +200 °C. Customized requirements with respect to geometrical and technical special solutions on request.

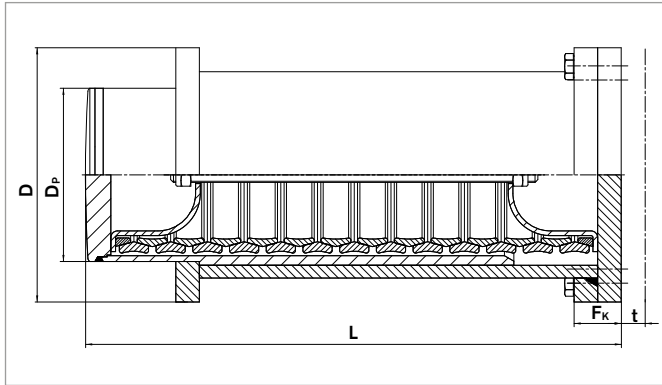

Design 1

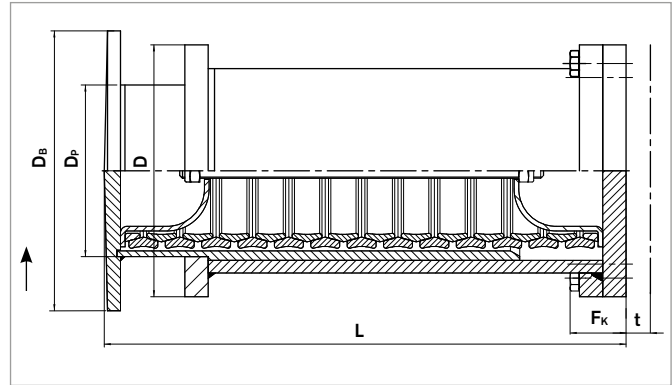

Design 2

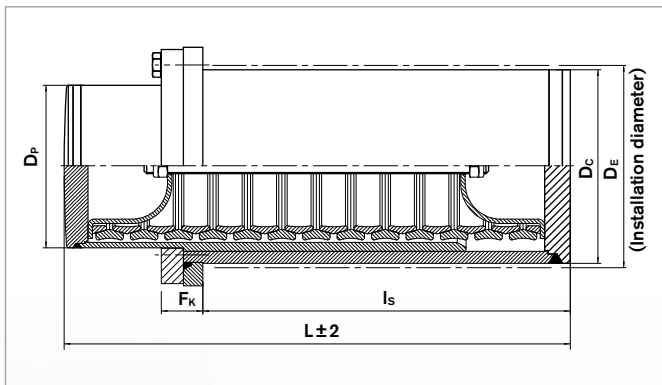

Design 3

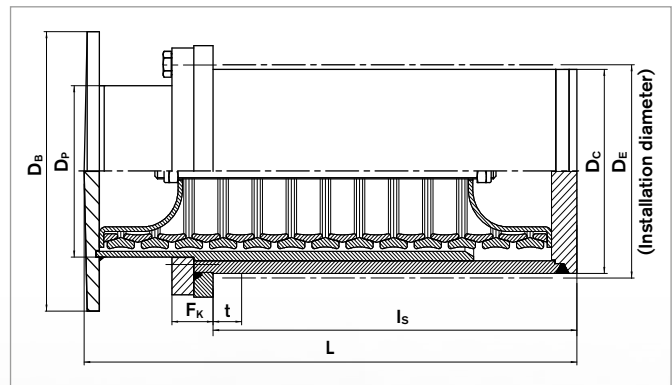

Design 4

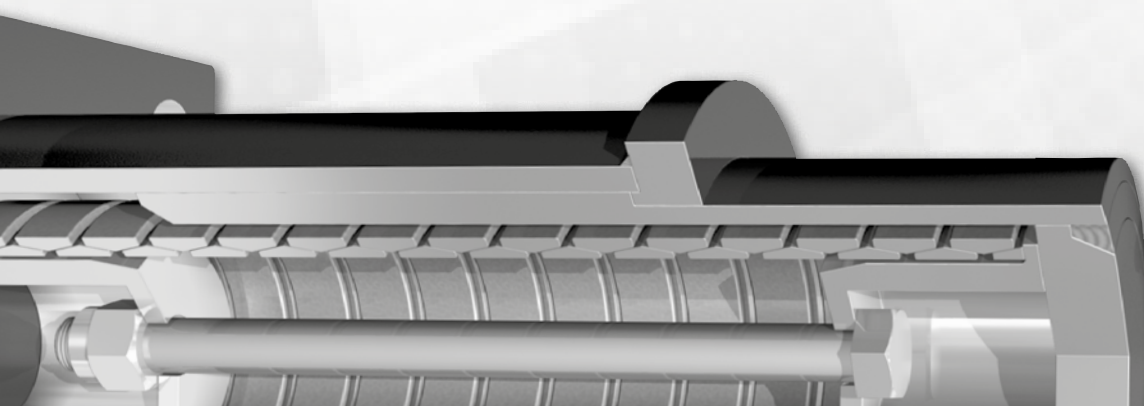

Not just for high velocities, but also with high masses and very slow loading rates, RINGFEDER® Friction Springs can provide solutions.



This 50.000 m³ gasometer by Thyssen Germany, uses buffers from RINGFEDER® to support the steel envelope but still allows expansion and contraction. Our buffers are characterised by very long operating lives.



RINGFEDER®

Earthquake protection

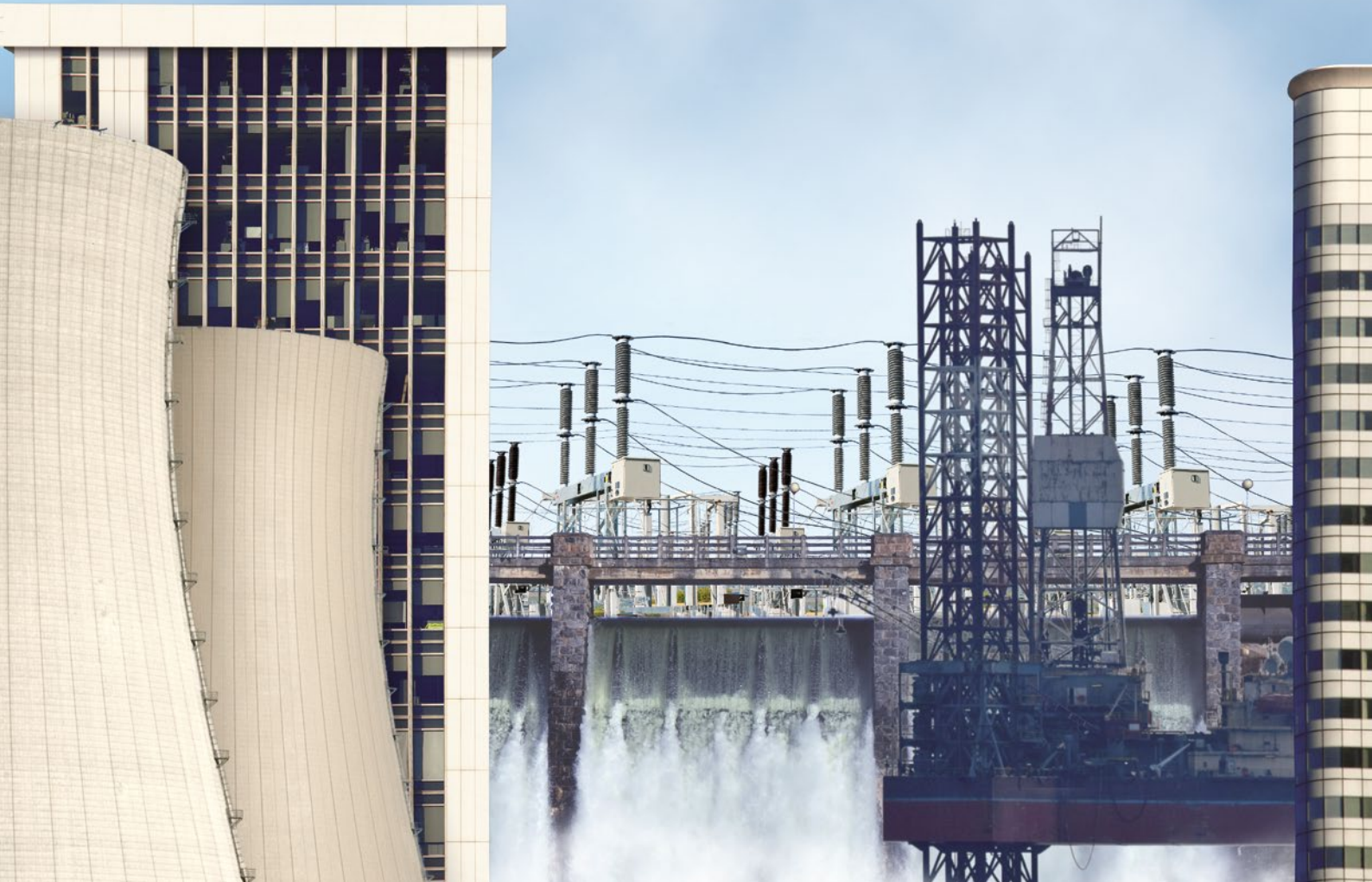

Friction springs will be more and more part of the future design systems for both, protection of residential buildings and systems for electricity transmission, for example high voltage switches or so-called wall bushings. Not all of the damage can be avoided that a big earthquake will cause, but with RINGFEDER® Friction Springs you have a great possibility that your building survives an earthquake like the ones in Christchurch 2010/11 and is still habitable. There already are build-

ings in New Zealand which are equipped with RINGFEDER® Friction Springs and are tested in reality. For example Te Puni Village Student Accommodation was already completed when the earthquake on July 21st 2013 occurred, measuring 6.5 on the Moment Magnitude Scale and the following aftershock measuring 5.8 on the MMS. The building withstood the earthquake without nameable damage.



Advantages

- 1. Long Life** – RINGFEDER® Friction Springs are designed to last through many cycles and are reusable. If one of the rings in a RINGFEDER® Friction Spring assembly breaks, the spring will still work but lose a little stroke and become slightly stiffer. The end force and the dampening remain unaffected. As a comparison, if a coil spring or a Belleville washer breaks, there will be a total failure and you have no protection any more.
- 2. Dampening** – Using our standard RINGFEDER® F-S1 grease, our friction springs will dampen 2/3 of the introduced energy. If you need less damping, we can easily design a customized solution that is tailored to your needs to achieve a reduced damping of about 1/3 of the introduced energy. This is a simple solution that can change the properties of the friction spring. In certain seismic designs you may require the friction spring to have a higher force as the spring is unloaded to help push the building structure back to its vertical position.
- 3. Fire and High Temperature** – Friction springs are made out of special spring-steel and coated with grease. In case of a fire, rubber products will be destroyed but our friction springs will endure the fire. You would just need to re-apply grease to the springs.
- 4. Return Force** – You can discuss your application with us to determine the best return force of the spring for your specific design. This is not possible with other, e.g. conventional spring types. We can change the grease, increase the outside diameter or change the taper angle to achieve the results you need.
- 5. Re-Usability** – Friction springs can be re-used after a seismic event. They are designed to withstand many cycles and remain stable. Friction springs are maintenance-free.
- 6. Speed** – Friction springs react faster to applied forces than any other spring type.
- 7. Space** – Friction springs give you the highest forces at a given diameter.



Te Puni Village Student Accommodation



Diagrams

How a RINGFEDER® Friction Spring works

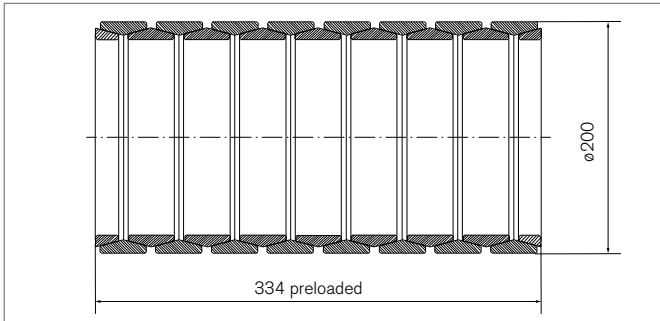

Figure 1

Figures 1 / 2 show a RINGFEDER® friction spring of type 20000, which consists of 8 outer rings, 7 inner rings and 2 half inner rings. It is preloaded with 200 kN to a length of 334 mm. With these values it has a maximum stroke of 38 mm and a capacity of 13400 Joule. The requirement is to absorb a maximum energy of 6000 Joule.

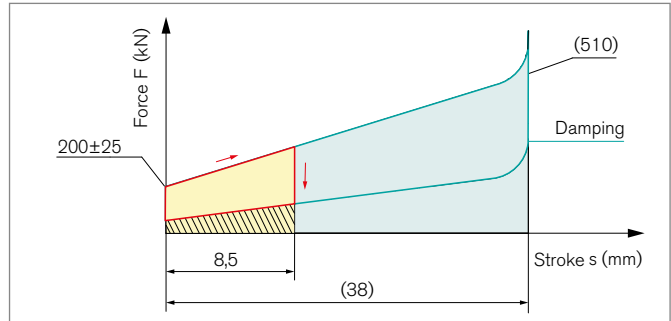

Diagram 2

Software Integration of RINGFEDER® Friction Springs

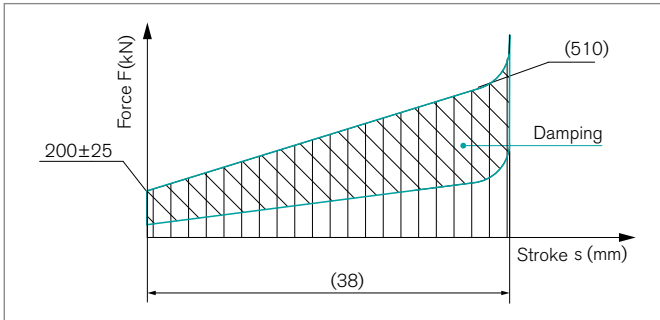

Figure 2

Diagram 1: When the RINGFEDER® Friction Spring receives an impact force, it compresses by 21 mm and absorbs 6000 Joule (=66%) from which 4000 Joule are converted to heat. After the compression, the RINGFEDER® Friction Spring discharges back by the same 21 mm due to a reaction force and there are 2000 Joule which has to be absorbed.

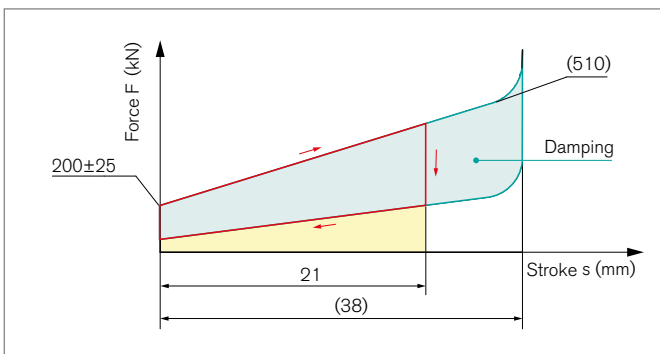
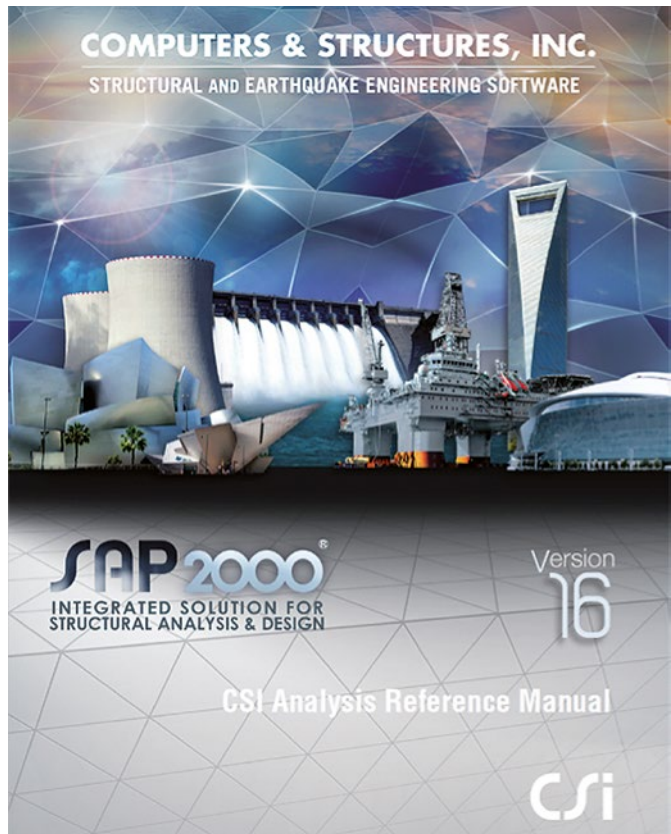

Diagram 1

Diagram 2: The impacting body strikes again on the RINGFEDER® Friction Spring with the remaining 2000 Joule and compress it by 8,5 mm. After the compression, the buffer springs back by the same 8,5 mm due to the reaction force. Based on the fact that the friction not only occurs between the rings of the friction spring but in the whole system, the complete 6000 Joule are now absorbed and the system comes to rest.



The friction spring is part of the SAP2000® software for the structural analysis and design of buildings, created by „Computers and Structures, Inc. (CSI)“.

CSI, based in California, USA, was founded in 1975 and has created many software packages for structural analysis including SAP2000® and ETABS®. ETABS® was used to create the mathematical model of the Burj Khalifa, currently the world's tallest building (gravity, wind and seismic response were all characterized using ETABS®).

Under the influence of strong breezes, tall structures – like here the TV/radio aerial of Brocken mountain, Germany – can get into transverse vibrations which endanger the complete construction. For prevention, RINGFEDER® Oscillation Dampers have been installed in combination with a pendular suspended mass, which safely protect aerials or smoke pipes under all temperature conditions.



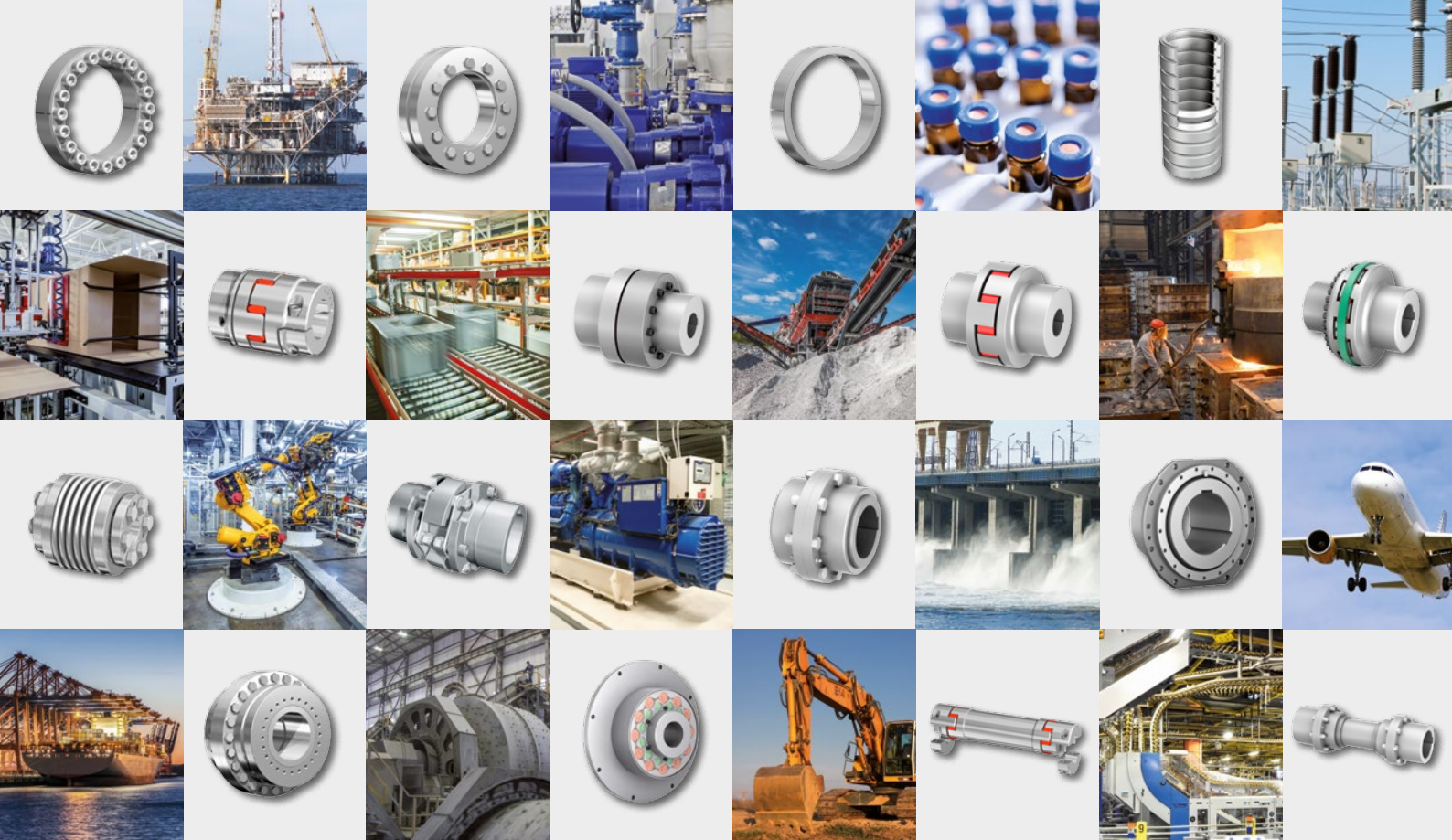

RINGFEDER POWER TRANSMISSION GMBH

Werner-Heisenberg-Straße 18, D-64823 Groß-Umstadt, Germany · Phone: +49 (0) 6078 9385-0 · Fax: +49 (0) 6078 9385-100
 E-mail: sales.international@ringfeder.com

RINGFEDER POWER TRANSMISSION TSCHAN GMBH

Zweibrücker Straße 104, D-66538 Neunkirchen, Germany · Phone: +49 (0) 6821 866-0 · Fax: +49 (0) 6821 866-4111
 E-mail: sales.tschan@ringfeder.com

RINGFEDER POWER TRANSMISSION USA CORPORATION

165 Carver Avenue, Westwood, NJ 07675, USA · Toll Free: +1 888 746-4333 · Phone: +1 201 666 3320 · Fax: +1 201 664 6053
 E-mail: sales.usa@ringfeder.com

HENFEL INDÚSTRIA METALÚRGICA LTDA.

Av. Major Hilário Tavares Pinheiro, 3447 · CEP 14871 300 · Jabcoticabal - SP - Brazil · Phone: +55 (16) 3209-3422
 E-mail: vendas@henfel.com.br

RINGFEDER POWER TRANSMISSION INDIA PRIVATE LIMITED

Plot No. 4, Door No. 220, Mount - Poonamallee Road, Kattupakkam, Chennai – 600 056, India
 Phone: +91 (0) 44-2679 1411 · Fax: +91 (0) 44-2679 1422 · E-mail: sales.india@ringfeder.com

KUNSHAN RINGFEDER POWER TRANSMISSION COMPANY LIMITED

NO. 406 Jiande Road, Zhangpu 215321, Kunshan, Jiangsu Province, China
 Phone: +86 (0) 512-5745-3960 · Fax: +86 (0) 512-5745-3961 · E-mail: sales.china@ringfeder.com

Partner for Performance
www.ringfeder.com

