

U-profiler

U-profiles

En U-profil er den rene gummiliste uden indlæg. Den fremstilles i flere forskellige størrelser, varianter og materialer som bl.a. EPDM, NR, CR, NBR, SBR og silikonegummi.

U-profiler er fortrinlige til at beskytte paneler, døre, kanter og glas og kan bruges i bl.a. maskiner, biler, møbler osv.

A U-profile is a pure rubber trim without inserts. It is produced in different sizes, variants and materials such as EPDM, NR, CR, NBR, SBR and silicone rubber.

U-profiles are excellent for protecting panels, doors, edges and glass and can be used for machines, cars, furniture, etc.

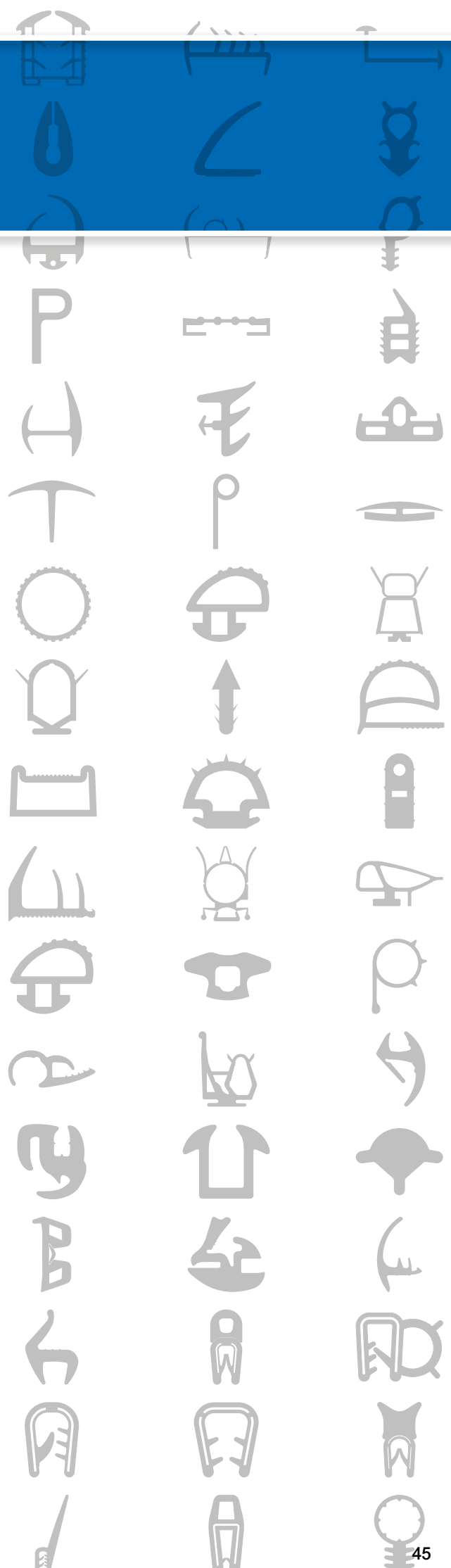

U-profiler / U-profiles

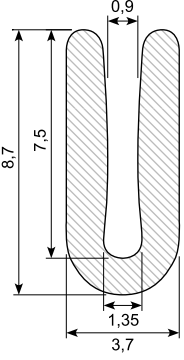
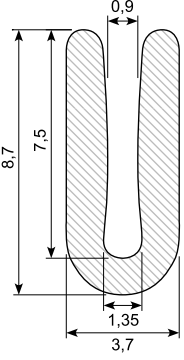
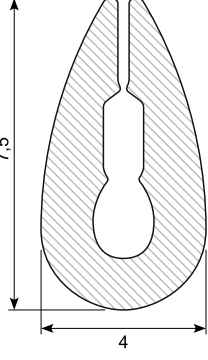
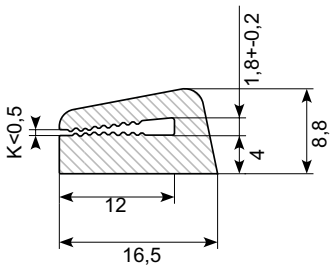
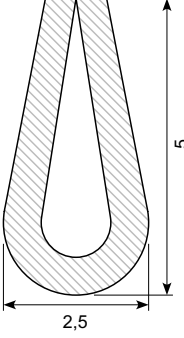
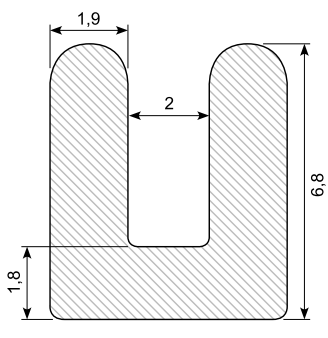
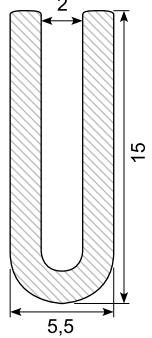
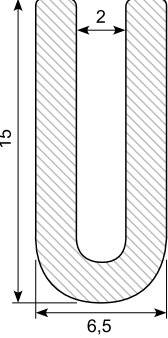
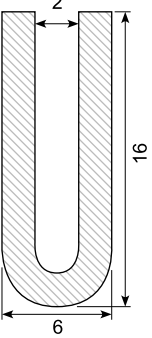
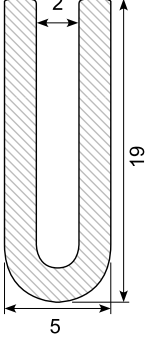
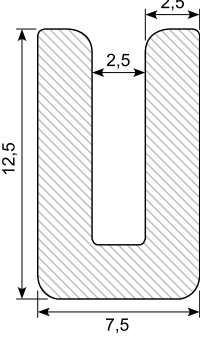
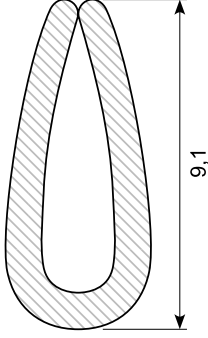
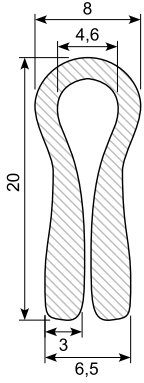
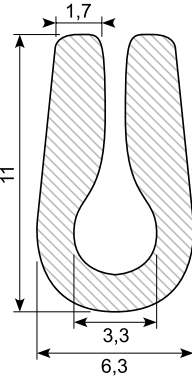
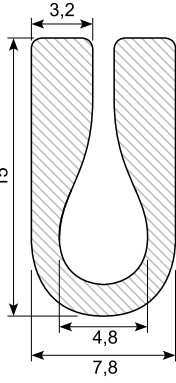
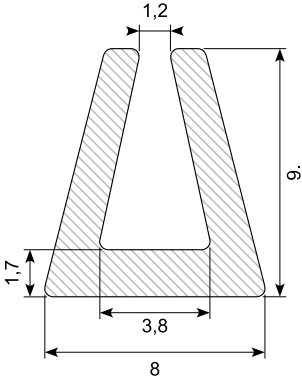
<p>31.018S *</p>  <p>Material: EPDM, black Hardness: SH 65 Min. order: 4.100 m</p>	<p>31.018X</p>  <p>Material: PVC, black Hardness: SH 65</p>	<p>34.018X</p>  <p>Material: PVC, light grey Hardness: Soft Plade: 1 mm</p>	<p>30.11393</p>  <p>Material: Silicone, grey Hardness: SH 50A</p>
<p>34.14334X</p>  <p>Material: Hard PVC, black Plade: 1,5 - 2 mm</p>	<p>31.060S</p>  <p>Material: EPDM, black Hardness: SH 65</p>	<p>31.041S</p>  <p>Material: EPDM, black Hardness: SH 65</p>	<p>31.042S</p>  <p>Material: EPDM, black Hardness: SH 65</p>
<p>30.OT3394 *</p>  <p>Material: Silicone, black Min. order: 100 m</p>	<p>31.047 *</p>  <p>Material: EPDM, black Hardness: SH 65 Min. order: 1.000 m</p>	<p>31.063</p>  <p>Material: EPDM, black Hardness: SH 65</p>	<p>30.9548</p>  <p>Material: PVC hard, light grey Length: 3,9 m</p>
<p>31.025S</p>  <p>Material: EPDM, black Hardness: SH 65</p>	<p>31.021S</p>  <p>Material: EPDM, black Hardness: SH 65</p>	<p>31.022S</p>  <p>Material: EPDM, black Hardness: SH 65</p>	<p>34.031X</p>  <p>Material: PVC, transparent Hardness: Soft</p>

U-profiler / U-profiles

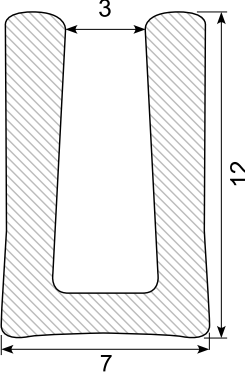
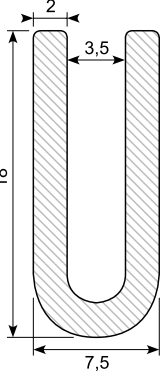
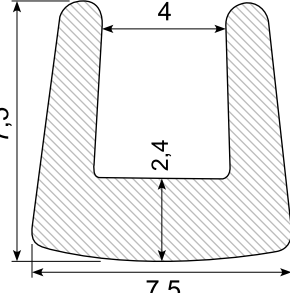
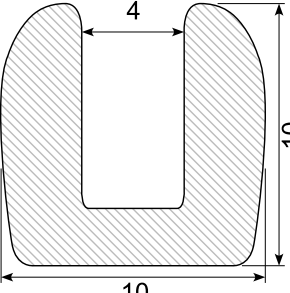
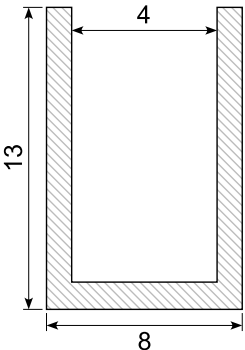
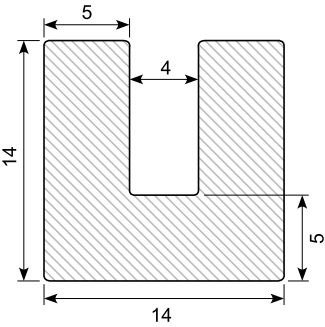
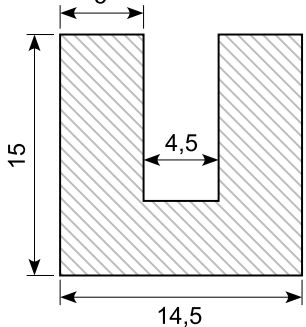
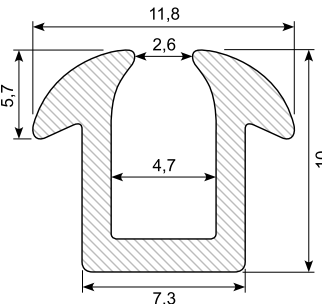
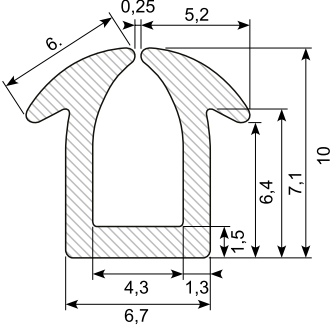
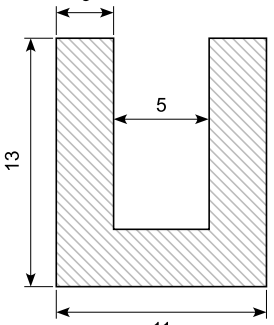
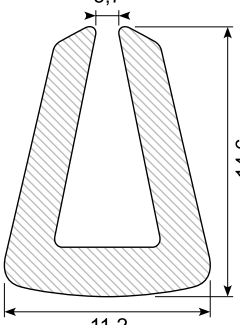
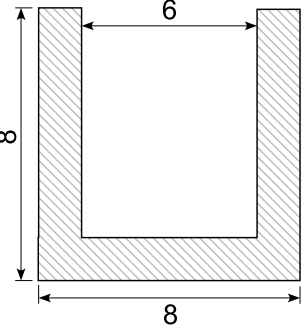
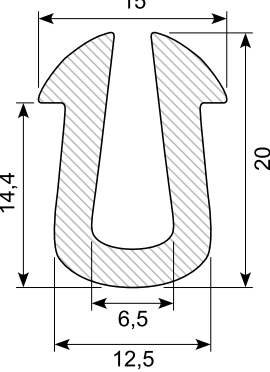
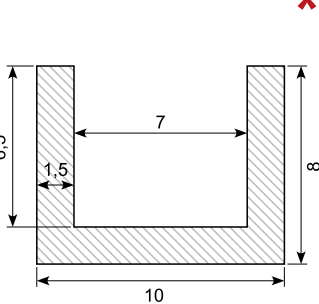
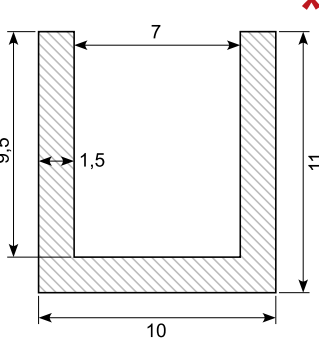
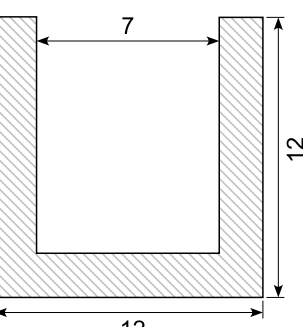
<p>30.13086</p>  <p>Material: EPDM, black Hardness: SH 80</p>	<p>31.043S</p>  <p>Material: EPDM, black Hardness: SH 65</p>	<p>31.064</p>  <p>Material: EPDM, black Hardness: Hard</p>	<p>31.065S</p>  <p>Material: EPDM, black Hardness: SH 65</p>
<p>31.061S</p>  <p>Material: EPDM, black Hardness: SH 65</p>	<p>30.6622N</p>  <p>Material: NBR, black Hardness: SH 65 Oil resistant</p>	<p>30.6622 *</p>  <p>Material: EPDM, black Hardness: SH 65 Min. order: 500 m</p>	<p>31.216ST</p>  <p>Material: EPDM, black Hardness: SH 65</p>
<p>31.216GS</p>  <p>Material: Silicone, light grey Ral 7040 Hardness: SH 70</p>	<p>30.11459 *</p>  <p>Material: Silicone, transparent Hardness: SH 45 Min. order: 250 m</p>	<p>34.035</p>  <p>Material: PVC, transparent Hardness: Hard</p>	<p>31.066</p>  <p>Material: Silicone, black Hardness: SH 70</p>
<p>30.6724</p>  <p>Material: EPDM, black Hardness: SH 65</p>	<p>30.14507-1 *</p>  <p>Material: EPDM, black Min. order: 3.000 m</p>	<p>30.14507-2 *</p>  <p>Material: EPDM, black Min. order: 3.000 m</p>	<p>31.068S</p>  <p>Material: EPDM, black Hardness: SH 65</p>

U-profiler / U-profiles

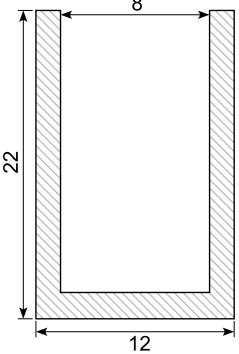
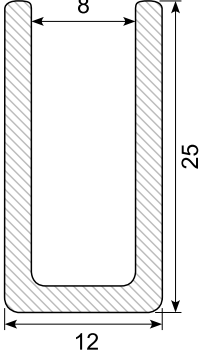
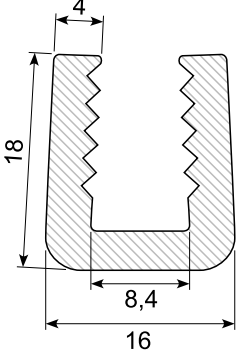
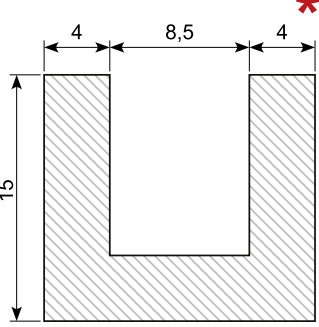
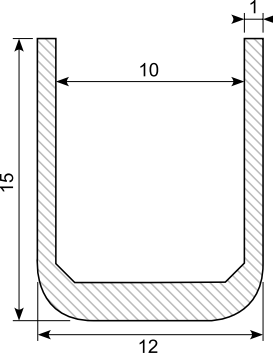
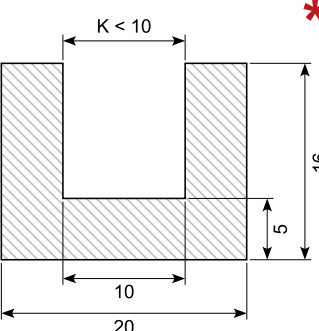
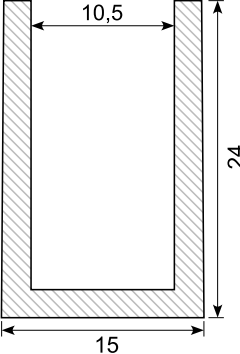
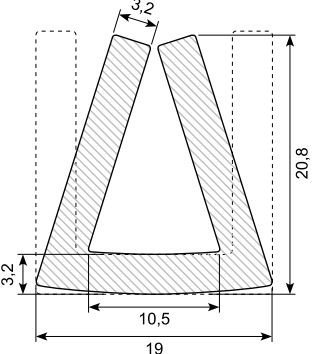
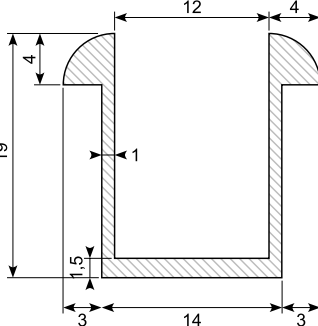
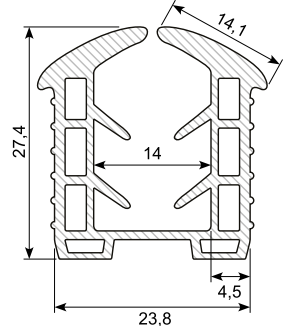
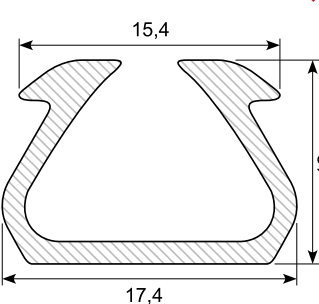
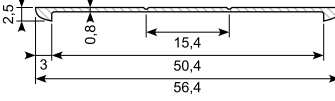
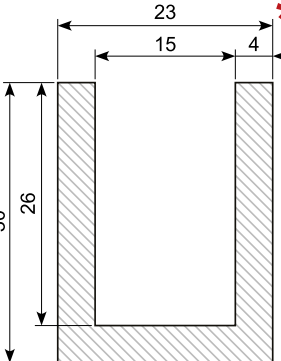
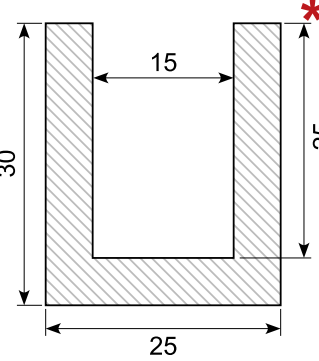
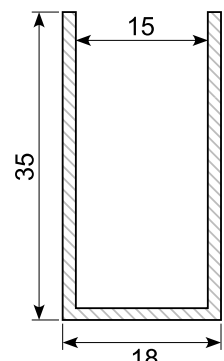
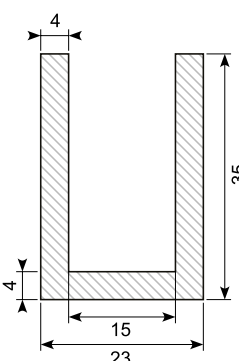
<p>30.1386</p>  <p>Material: EPDM, black Hardness: SH 65</p>	<p>30.OT3440 *</p>  <p>Material: Silicone, black Hardness: SH 60 Min. order: 100 m</p>	<p>30.12896</p>  <p>Material: EPDM, black Hardness: SH 65</p>	<p>31.074S *</p>  <p>Material: EPDM, black Min. order: 1.000 m</p>
<p>30.7987</p>  <p>Material: EPDM, black Hardness: SH 65</p>	<p>30.OT0136 *</p>  <p>Material: Silicone, white Min. order: 100 m</p>	<p>31.070S</p>  <p>Material: EPDM, black Hardness: SH 50</p>	<p>31.071S</p>  <p>Material: EPDM, black Hardness: SH 65</p>
<p>30.2455</p>  <p>Material: PVC, black Length: 3.111 mm</p>	<p>30.11774 *</p>  <p>Material: EPDM Hardness: SH 65 10-13 mm glass</p>	<p>30.7508 *</p>  <p>Material: EPDM, black Hardness: SH 65 Min. order: 400 m</p>	<p>30.9519 *</p>  <p>Material: PVC soft, black Min. order: 7.000 m</p>
<p>30.12932-1 *</p>  <p>Material: EPDM, black Hardness: SH 60A Min. order: 500 m</p>	<p>30.13535 *</p>  <p>Material: EPDM, black Hardness: SH 60 Min. order: 420 m</p>	<p>30.7509</p>  <p>Material: EPDM, black Hardness: SH 65</p>	<p>30.10777-1 *</p>  <p>Material: TPE, black Hardness: SH 60 Min. order: 100 m</p>

U-profiler / U-profiles

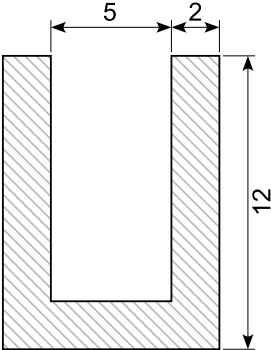
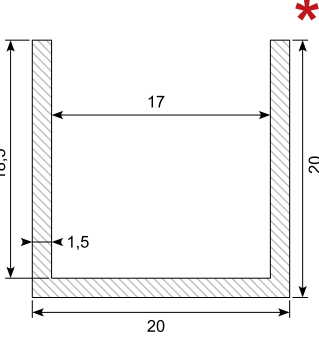
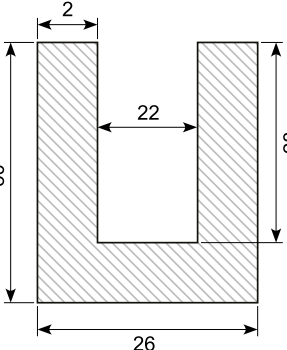
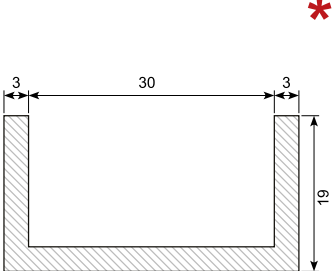
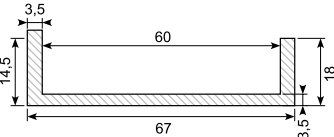
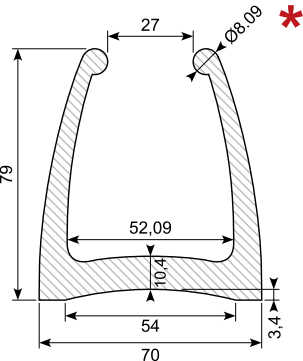
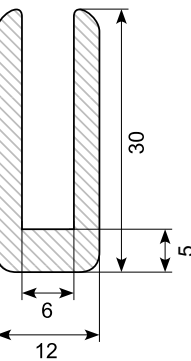
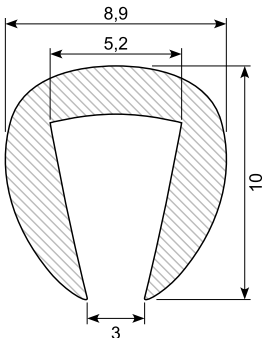
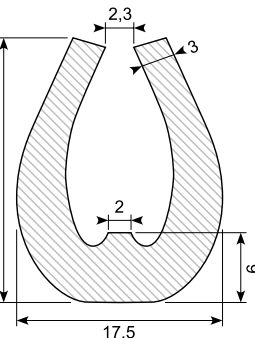
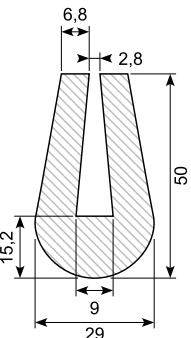
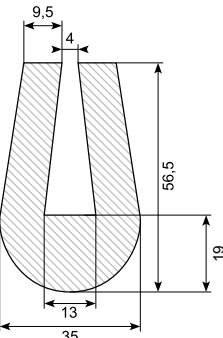
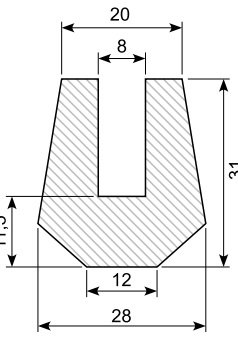
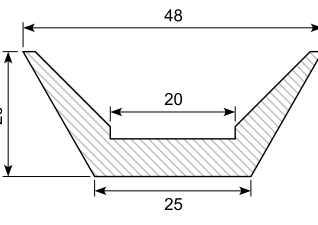
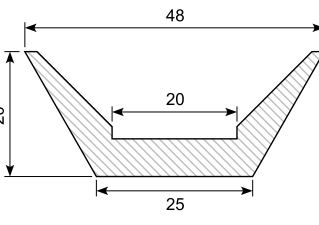
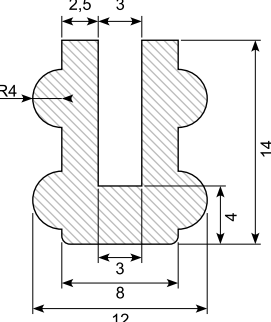
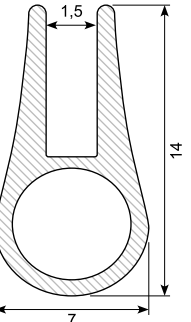
<p>30.21101205</p>  <p>Material: EPDM Hardness: SH 70</p>	<p>30.14507-3</p>  <p>Material: EPDM Min. order: 2.000 m</p>	<p>31.050</p>  <p>Material: EPDM, black Hardness: SH 65</p>	<p>30.14356</p>  <p>Material: TPE, black Hardness: SH 60 Min. order: 50 - 100 m</p>
<p>31.048</p>  <p>Material: EPDM, black Hardness: SH 65 Min. order: 250 m</p>	<p>30.11911</p>  <p>Material: EPDM Hardness: SH 65 Min. order: 120 m</p>	<p>30.2984-5</p>  <p>U-profile Material: EPDM Hardness: SH 70</p>	<p>34.117/6</p>  <p>Material: Plastic, metal grey</p>
<p>30.2984-6</p>  <p>U-profile Material: EPDM Hardness: SH 80 Roll of 50 m</p>	<p>30.2984-1</p>  <p>U-profile Material: EPDM Hardness: SH 70 Roll of 25 m</p>	<p>30.2984-2</p>  <p>U-profile Material: EPDM Hardness: SH 65 Roll of 25 m</p>	<p>30.2984-3</p>  <p>U-profile Material: EPDM Hardness: SH 70 Roll of 25 m</p>
<p>30.7519NBR</p>  <p>Material: NBR, grey Hardness: SH 65 Length: 3 m Oil resistant Min. order: 500 m</p>	<p>30.7519</p>  <p>Material: EPDM, black Hardness: SH 65 Length: 50 m coils Min. order: 50 - 250 m</p>	<p>30.14227</p>  <p>Material: Silicone, transparent Min. order: 100 m</p>	<p>31.037SI</p>  <p>Material: Silicone, black</p>

U-profiler / U-profiles

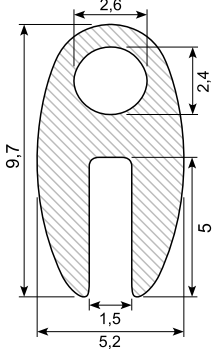
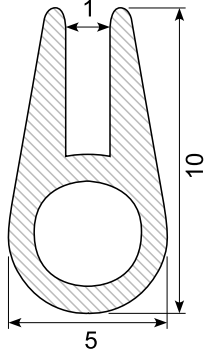
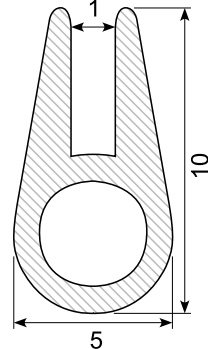
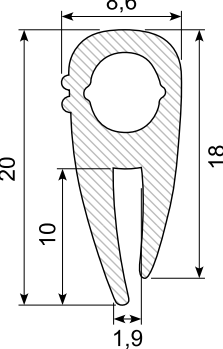
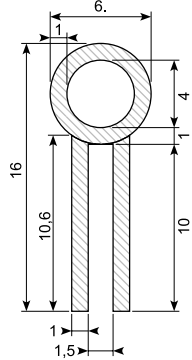
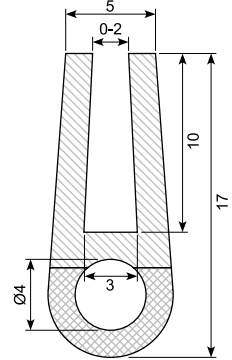
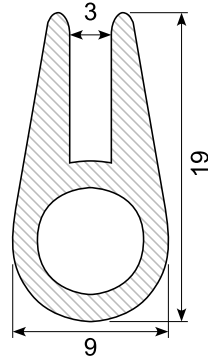
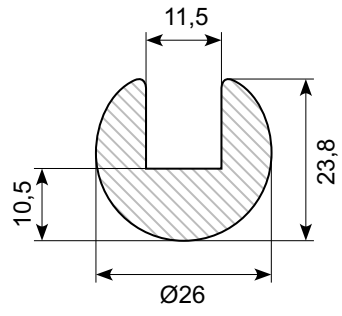
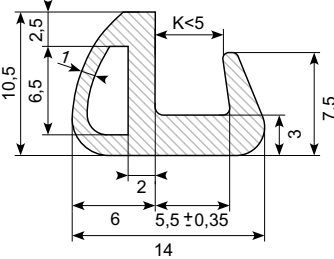
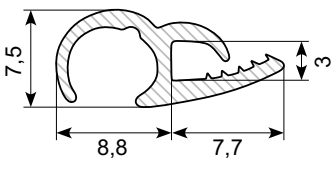
<p>31.035S</p>  <p>Material: EPDM, black Hardness: SH 65</p>	<p>31.036SI *</p>  <p>Material: Silicone, black Min. order: 200 m</p>	<p>31.036SI-LTC</p>  <p>Material: Silicone, black UL94 approved</p>	<p>30.9884X *</p>  <p>Material: EPDM Min. order: 3.000 m</p>
<p>31.037 *</p>  <p>Material: EPDM Hardness: SH 56 - 60A Min. order: 2.000 m</p>	<p>30.9885</p>  <p>Material: EPDM Hardness: SH 60</p>	<p>31.038SI</p>  <p>Material: Silicone, black Hardness: SH 60</p>	<p>30.211.04.385</p>  <p>Material: EPDM Hardness: SH 70A</p>
<p>30.11580</p>  <p>Material: Silicone, black. With balloon Hardness: SH 55A Weight: 81 g pr. m</p>	<p>31.040</p>  <p>U-rubber profile Hardness: SH 65A</p>		