

# Svampegummi

## Sponge rubber

Svampegummi er en opskummet og blødere gummitype med en mere åben struktur og større elasticitet. Det gør materialet optimalt til forsegling eller tætning.

Skal du bruge forsegling, hvor der f.eks. er store krav til UV- eller temperaturrestandigheden? Eller måske til udfyldnings- og tætningsopgaver i industrien? De forseglende egenskaber er anvendelige i en lang række af industrier.

Tætningsegenskaberne ved denne gummitype kan f.eks. bruges omkring ventilations- og klimaanlæg eller ved stanseforme, lamper, karrosseridele, stål-skabe og døre. Svampegummi kan findes i forskellige gummityper med flere typer af klæb.

Sponge rubber is a foamed and softer type of rubber with a more open structure and greater elasticity, making the material optimal for sealing or caulking.

Do you need a sealer with high UV- or temperature resistance? Or perhaps for sealing and caulking applications in industry? The sealing properties of sponge rubber are useful in a variety of industries.

For example, the sealing properties of this type of rubber can be used around ventilation and air conditioning systems, as well as for cutting dies, lamps, body panels, steel cabinets and steel doors. Sponge rubber is available with different types of adhesive and rubber.

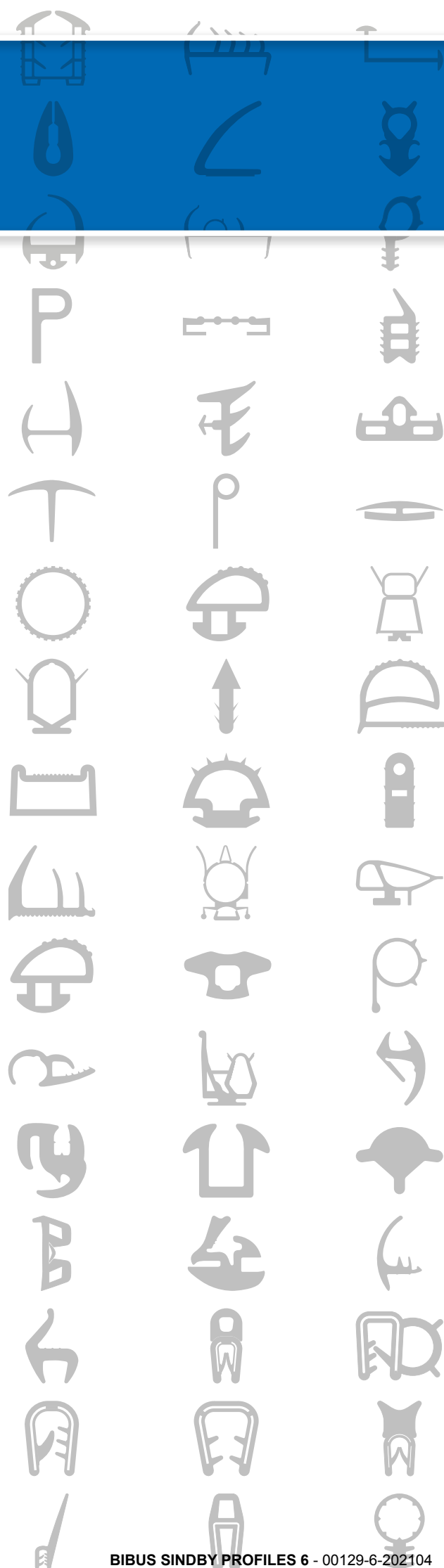

# Svampegummi / Sponge rubber

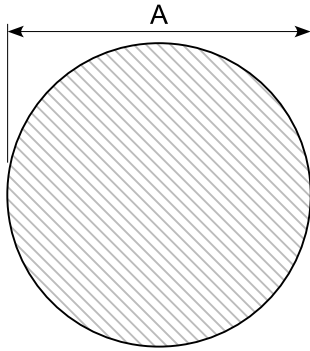

Material: EPDM, **dark grey**  
Hardness: SH 16 - 20 /  
density 0,4 - 0,5

Art.	Ø (mm)
36.102E	2
36.1025E *	2,5
36.103E	3
36.1035E	3,5
36.1045E *	4,5
36.105E *	5
36.106E	6
36.106EG * (Light grey)	6
36.106ESP *	6
36.107E	7
36.108E *	8
36.108EG * (Light grey)	8
36.109E *	9
36.110E *	10
36.111E *	
36.112E *	12
36.112EG * (Light grey)	12
36.117E	17
36.120E	20
36.122E *	22
36.125E	25
36.130EX *	30
36.135E *	35

Material: EPDM, **black**  
Hardness: SH 16 - 20 /  
density 0,45 - 0,6

Art.	Ø (mm)	Min. order
36.7004.5X *	4,5	3.000
36.7005X *	5	3.000
36.7006X *	6	3.000
36.7007X *	7	3.000
36.7008X *	8	3.000
36.7008.5X *	8,5	3.000
36.7009X *	9	3.000
36.7010X *	10	3.000
36.7010.5X *	10,5	3.000
36.7011X *	11	3.000
36.7011.5X *	11,5	3.000
36.7012X *	12	3.000
36.7014X *	14	3.000
36.7018X *	18	
36.7028X *	28	
36.7064X *	64	

Material: EPDM, **black**  
Hardness: SH 16 - 20 /  
density 0,45 - 0,6

Art.	Ø (mm)
36.7003 *	3
36.7004	4
36.7005	5
36.7006 *	6
36.7008	8
36.7009	9
36.7010	10
36.7012	12
36.7015	15
36.7050 *	50

Material: CR, **dark grey**  
Hardness: SH 16 - 22 /  
density 0,4 - 0,6

Art.	Ø (mm)
36.103CR	3
36.104CR	4
36.105CR	5
36.106CR	6
36.107CR	7
36.108CR *	8
36.110CR	10
36.112CR	12
36.115CR (Black)	15
36.118CR * (Black)	18
36.119CR *	19
36.120CR *	20
36.122CR	22

Material: NR, **dark grey**  
Hardness: SH 16 - 22 /  
density 0,4 - 0,55

Art.	Ø (mm)
36.102 *	2
36.102.5 *	2,5
36.103 *	3
36.104 *	4
36.106 *	6
36.108	8
36.110 *	10
36.112	12
36.115 *	15
36.120 *	20
36.125 *	25
36.130 *	30

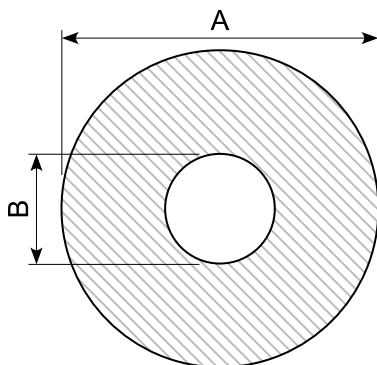

Material: EPDM, **black**

Art.	A x B (mm)	Min. order
36.3416068 *	16 x 6,8	
36.34155105 *	15,5 x 10,5	
36.344511 *	45 x 11	
36.341840 *	40 x 18	<b>200 m</b>
36.342026 *	26 x 20	<b>1.000 m</b>
36.342030 *	30 x 20	<b>550 m</b>
36.342226 *	26 x 22	<b>1.000 m</b>
36.342232 *	32 x 22	<b>500 m</b>
36.342433 *	33 x 24	<b>500 m</b>
36.342529 *	29 x 25	<b>1.000 m</b>
36.342840 *	40 x 28	<b>250 m</b>

# Svampegummi / Sponge rubber

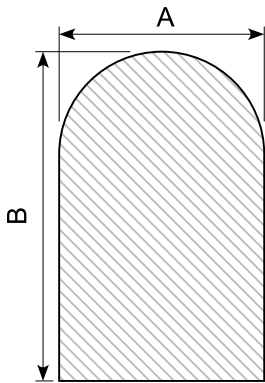

**Material: EPDM**

Art.	A x B (mm)	Color
36.198	6 x 8	Grey
36.198S	6 x 8	Black
36.199	6 x 10	Light grey
36.208	10 x 20	Light grey
36.3314	12 x 17	Dark grey

**Material: CR**

**Hardness: SH 16 - 20 / density 0,4**

Art.	A x B (mm)	Color
36.198CR *	6 x 8	Dark grey
36.200	8 x 8	Dark grey
36.202	10 x 12	Dark grey

**Material: NR**

**Hardness: SH 16 - 20 / density 0,45 - 0,6**

Art.	A x B (mm)	Color
36.197	4 x 6	Blue grey
36.198A *	6 x 8	Blue grey

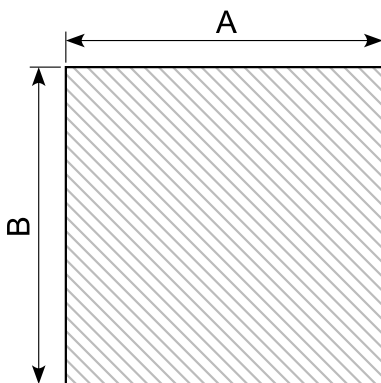

**Material: EPDM, dark grey**

**Hardness: SH 14 - 16 / density 0,38 - 0,42**

Flere størrelser kan skaffes. Find den komplette liste af svampegummiværktøjer på hjemmesiden ved at scanne QR-koden.

Other sizes can be ordered. Scan the QR-code to see the complete list on our homepage.



Art.	A x B (mm)	Art.	A x B (mm)	Art.	A x B (mm)	Art.	A x B (mm)
35.0806 *	8 x 6	35.1515	15 x 15	35.2510	25 x 10	35.3535	35 x 35
35.1003 *	10 x 3	35.1605	16 x 5	35.2515	25 x 15	35.4005 *	40 x 5
35.1004 *	10 x 4	35.1608 *	16 x 8	35.2520	25 x 20	35.4010	40 x 10
35.1005	10 x 5	35.2003	20 x 3	35.2525	25 x 25	35.4020	40 x 20
35.1007 *	10 x 7	35.2005	20 x 5	35.3005 *	30 x 5	35.4030 *	40 x 30
35.1008	10 x 8	35.20055 *	20 x 5,5	35.3007	30 x 7	35.4035 *	40 x 35
35.1010	10 x 10	35.2010	20 x 10	35.3010	30 x 10	35.4040	40 x 40
35.1203 *	12 x 3	35.2012	20 x 12	35.3012 *	30 x 12	35.4505 *	45 x 5
35.1209 *	12 x 9	35.2015	20 x 15	35.3015	30 x 15	35.5005 *	50 x 5
35.1212	12 x 12	35.2018 *	20 x 18	35.3020	30 x 20	35.5006 *	50 x 6
35.1503 *	15 x 3	35.2020	20 x 20	35.3025	30 x 25	35.5010 *	50 x 10
35.1507 *	15 x 7	35.2502	25 x 2	35.3030	30 x 30	35.5010E	50 x 10
35.1510	15 x 10	35.2505	25 x 5	35.3505 *	35 x 5	35.6010 *	60 x 10
35.1512 *	15 x 12	35.2506 *	25 x 6	35.3510 *	35 x 10	35.6040 *	60 x 40

# Svampegummi / Sponge rubber

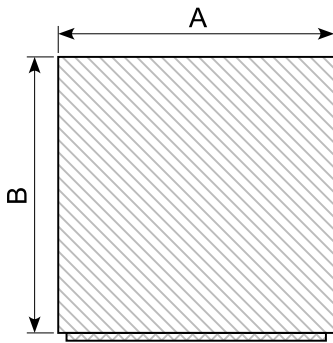

Material: EPDM, **dark grey**

Hardness: SH 14 - 16 / density 0,38 - 0,42

**With adhesive**



Flere størrelser kan skaffes. Find den komplette liste af svampegummiværktøjer på hjemmesiden ved at scanne QR-koden.

Other sizes can be ordered. Scan the QR-code to see the complete list on our homepage.

Art.	A x B (mm)
35.0806K *	8 x 6
35.0808K *	8 x 8
35.1003K	10 x 3
35.1004K *	10 x 4
35.1005K	10 x 5
35.1007K *	10 x 7
35.1008K	10 x 8
35.1010K	10 x 10
35.1203K *	12 x 3
35.1204K *	12 x 4
35.1204KL	12 x 4
35.1206K *	12 x 6
35.1208K *	12 x 8
35.1209K *	12 x 9
35.1212K *	12 x 12
35.1503K *	15 x 3
35.1504K	15 x 4
35.1505K	15 x 5
35.1506K	15 x 6
35.1507K *	15 x 7

Art.	A x B (mm)
35.1510K	15 x 10
35.1512K *	15 x 12
35.1515K	15 x 15
35.1605K *	16 x 5
35.1608K *	16 x 8
35.1708K *	17 x 8
35.1803K *	18 x 3
36.1808KX	18 x 8
35.18053K *	18 x 5,3
35.1809K *	18 x 9
35.1904K *	19 x 4
35.2003K	20 x 3
35.2005K	20 x 5
35.2006K	20 x 6
35.20055K *	20 x 5,5
35.2010K *	20 x 10
35.2010KL	20 x 10
35.2012K	20 x 12
35.2015K	20 x 15
35.2020K	20 x 20

Art.	A x B (mm)
35.2207K *	22 x 7
35.2505K	25 x 5
35.2508K *	25 x 8
35.2510K	25 x 10
35.2515K	25 x 15
35.2520K	25 x 20
35.2525K	25 x 25
35.2806K	28 x 6
35.3003K	30 x 3
35.3005K	30 x 5
35.3006K	30 x 6
35.3007K *	30 x 7
35.3010K	30 x 10
35.3012K	30 x 12
35.3015K	30 x 15
35.3020K	30 x 20
35.3025K *	30 x 25
35.3030K	30 x 30
35.3505K *	35 x 5

Art.	A x B (mm)
35.3510K *	35 x 10
35.3535K *	35 x 35
35.4003K	40 x 3
35.4005K	40 x 5
35.4010K	40 x 10
35.4012K *	40 x 12
35.4020K *	40 x 20
35.4030K	40 x 30
35.4035K	40 x 35
35.4040K	40 x 40
35.4505K *	45 x 5
35.5006K	50 x 6
35.5010K	50 x 10
35.5020K *	50 x 20
35.6002K	60 x 2
35.8020K *	80 x 20
35.10020K *	100 x 20

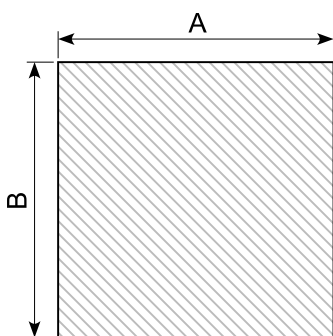

Material: EPDM, **dark grey**

Hardness: SH 16 - 20 density 0,4 - 0,5

Art.	A x B (mm)
36.1010E	10 x 10
36.1210E *	12 x 10
36.1503E *	15 x 3
36.1505E	15 x 5
36.1510E	15 x 10
36.1512E *	15 x 12
36.1612E *	16 x 12
36.1815EG*	18 x 15

Art.	A x B (mm)
36.2010E	20 x 10
36.2510E	25 x 10
36.2520E *	25 x 20
36.2525E *	25 x 25
36.3010E	30 x 10
36.3025E	30 x 25
36.3520E *	35 x 20
36.4010E *	40 x 10

Art.	A x B (mm)
36.4015E	40 x 15
36.4020E *	40 x 20
36.4025E *	40 x 25
36.4030E	40 x 30
36.5020E *	50 x 20
36.6030E *	60 x 30

# Svampegummi / Sponge rubber

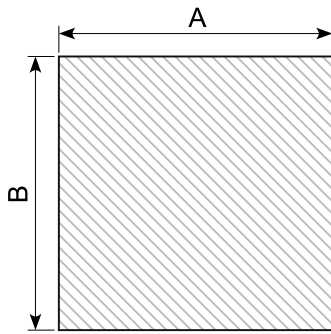

Material: NR, **dark grey**

Hardness: SH 16 - 20 density 0,4 - 0,5

Art.	A x B (mm)
36.0505 *	5 x 5
36.0806 *	8 x 6
36.1003	10 x 3
36.1005 *	10 x 5
36.1005G <b>light grey</b> *	10 x 5
36.1007 *	10 x 7
36.1008 *	10 x 8
36.1010 <b>black</b>	10 x 10
36.1205 *	12 x 5
36.1206 *	12 x 6
36.1210	12 x 10
36.1503 *	15 x 3
36.1510	15 x 10
36.1512 *	15 x 12
36.1515	15 x 15
36.1604	16 x 4

Art.	A x B (mm)
36.1605 *	16 x 5
36.1808G *	18 x 8
36.1816 *	18 x 16
36.2002 *	20 x 2
36.2003 *	20 x 3
36.2005	20 x 5
36.2010	20 x 10
36.2015	20 x 15
36.2020	20 x 20
36.2503 *	25 x 3
36.2505	25 x 5
36.2510	25 x 10
36.2515	25 x 15
36.2520 *	25 x 20
36.2525	25 x 25
36.3003 *	30 x 3

Art.	A x B (mm)
36.3005	30 x 5
36.3010	30 x 10
36.3015	30 x 15
36.3020	30 x 20
36.3030	30 x 30
36.3516 *	35 x 16
36.4010 *	40 x 10
36.4012 *	40 x 12
36.4015 *	40 x 15
36.4025	40 x 25
36.5010 *	50 x 10
36.5020	50 x 20
36.5025 *	50 x 25
36.5030	50 x 30

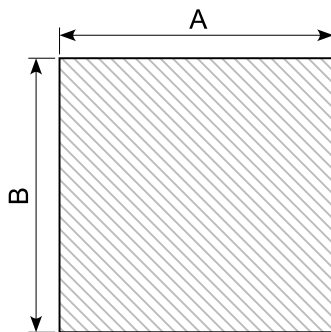

Material: Economy EPDM, **black**

Hardness: Density 0,45

Art.	A x B (mm)	Min. order (m)
36.1005X *	10 x 5	3.000
36.1505X *	15 x 5	3.000
36.2005X *	20 x 5	3.000
36.2505X *	25 x 5	3.000
36.3005X *	30 x 5	
36.1406X *	14 x 6	3.000
36.1007X *	10 x 7	3.000
36.1507X *	15 x 7	3.000
36.2507X *	25 x 7	3.000
36.2008X	20 x 8	
36.2508X *	25 x 8	3.000
36.1010X *	10 x 10	3.000
36.1210X *	12 x 10	3.000
36.2010X	20 x 10	
36.4010X *	40 x 10	2.000

Art.	A x B (mm)	Min. order (m)	
36.5010X *	50 x 10	1.000	
36.12511X *	12,5 x 11	3.000	
36.1212X *	12 x 12	3.000	
36.1612X *	16 x 12	3.000	
36.2318X *	23 x 18	2.000	
36.3015X *	30 x 15	1.500	
36.3515X *	35 x 15	1.500	
36.4020X	40 x 20	3.000	
36.3003X *	30 x 3		
36.3006X *	30 x 6	3.000	
36.3020X *	30 x 20	1.500	Soft corners
36.3305X *	33 x 5	3.000	
36.3520X	35 x 20	1.000	Soft corners
36.5005X *	50 x 5	2.000	
36.2512X	25 x 12	2.000	Soft corners

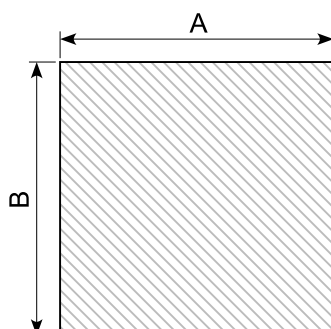

Material: CR, **black**

Hardness: SH 18 - 25 density 0,5 - 0,75

Art.	A x B (mm)
36.1010CR *	10 x 10
36.2010CR *	20 x 10
36.2020CR *	20 x 20
36.3015CR	30 x 15
36.64004CR *	40 x 4
36.4020CR *	40 x 20
36.60503CR *	50 x 3
36.5005CR *	50 x 5

# Svampegummi / Sponge rubber

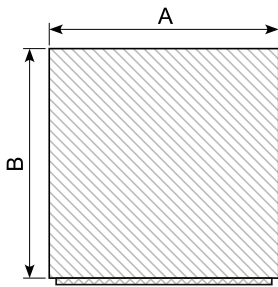

**Industry Quality:** -60 °C / +220 °C  
**With tape:** -60 °C / +180 °C  
**Material:** Silicone, **off white**  
**Hardness:** SH 16 - 20 / density 0,4 - 0,5  
**F: FDA**  
**K: with adhesive**

Art.	A x B (mm)
36.1010SIH *	10 x 10
36.1512SIH *	15 x 12
36.1515SIH	15 x 15
36.1610SIH	16 x 10
36.2003SIH *	20 x 3
36.2010SIH *	20 x 10
36.2010SIHK *	20 x 10
36.2015SIH *	20 x 15
36.2020SIH *	20 x 20
36.2020SIHF *	20 x 20
36.2505SIH	25 x 5
36.2505SIHF *	25 x 5
36.2510SIH	25 x 10
36.2515SIH *	25 x 15
36.2520SIH	25 x 20
36.3005SIHK *	30 x 5
36.3020SIH *	30 x 20
36.4005SIHK *	40 x 5
36.4012SIH *	40 x 12

**Industry Quality:** -60 °C / +200 °C  
**Material:** Silicone, **white**  
**Hardness:** SH 16 - 20 / density 0,55 - 0,65  
**Compliant to (E6) 1935/2004 and EU 10/2011 in contact with food**  
**F: FDA**  
**K: with adhesive. These can not be used in contact with food**

Art.	A x B (mm)
36.1204SIHKF *	12 x 4
36.1505SIHF *	15 x 5
36.1616SIHF *	16 x 16
36.2005SIHF *	20 x 5
36.3005SIHKF *	30 x 5

**Industry Quality:** -60 °C / +200 °C  
**Material:** Silicone, **white**  
**Hardness:** SH 16 - 20 / density 0,55 - 0,65

Art.	A x B (mm)
36.1006SIH	10 x 6
36.1212SIH	12 x 12
36.1505SIH	15 x 5
36.2525SIH	25 x 25
36.3010SIH *	30 x 10
36.5005SIH *	50 x 5

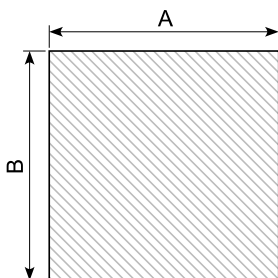

**Material: NBR**

Art.	A x B (mm)
36.2010SIS *	20 x 10
36.2520SIS *	25 x 20

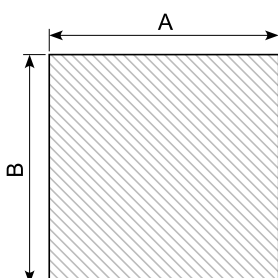

**Material: NBR**

Art.	A x B (mm)
36.6020NBR	60 x 20

# Svampegummi / Sponge rubber



## Sponge rubber plates

Material: EPDM / NR

Color: Dark grey

Art.	Length (mm)	Thickness (mm)	Width (mm)	Quality
38.152EPDM	1.000	2	1.000	EPDM
38.153EPDM	1.000	3	1.000	EPDM
38.154EPDM	1.000	4	1.000	EPDM
38.155EPDM	1.000	5	1.000	EPDM
38.156EPDM	1.000	6	1.000	EPDM
38.158EPDM	1.000	8	1.000	EPDM
38.160EPDM	1.000	10	1.000	EPDM
38.162EPDM	1.000	12	1.000	EPDM
38.165EPDM	1.000	15	1.000	EPDM
38.170EPDM	1.000	20	1.000	EPDM
38.175EPDM	1.000	25	1.000	EPDM
38.180NR *	1.000	30	1.000	NR

## Svampegummi i svøb (lugepakninger)

36.K608 *	36.K613 *	36.K616 *	36.K671 *
<p>Color: Black</p>	<p>Color: Black</p>	<p>Color: Black</p>	<p>Color: Black</p>
36.K675 *	36.K676 *	36.K677 *	36.K678 *
<p>Color: Black</p>	<p>Color: Black</p>	<p>Color: Black</p>	<p>Color: Black</p>
36.K679 *	36.K680 *	36.K681 *	36.K683 *
<p>Color: Black</p>	<p>Color: Black</p>	<p>Color: Black</p>	<p>Color: Black</p>

# Svampegummi / Sponge rubber

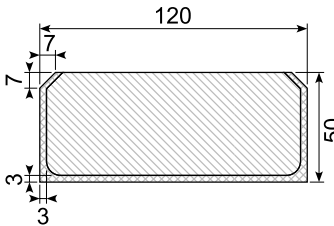
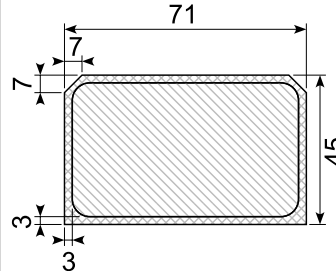
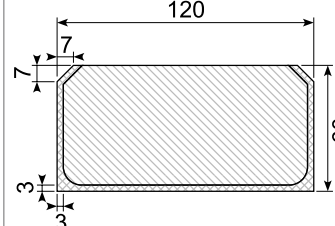
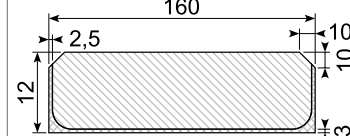
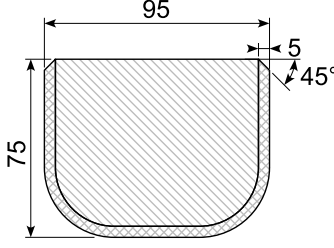
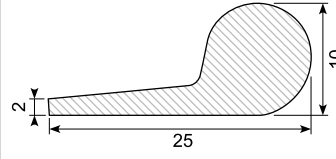
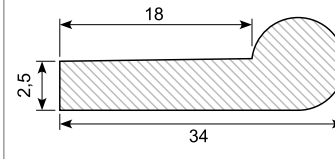
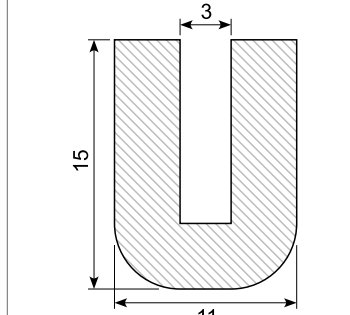
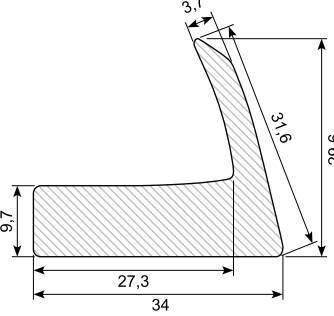
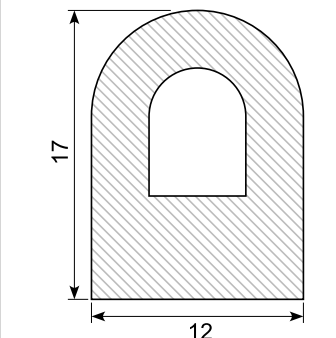
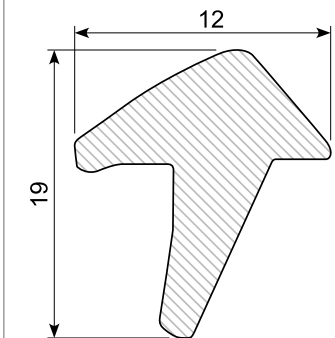
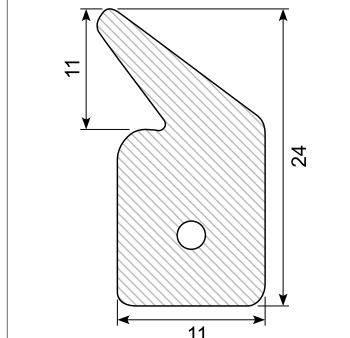
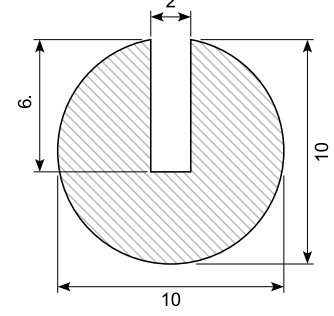
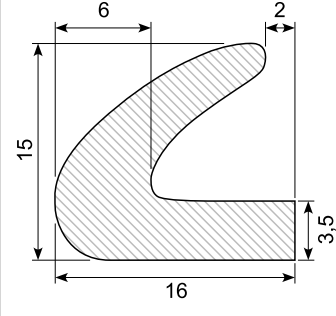
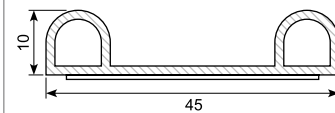
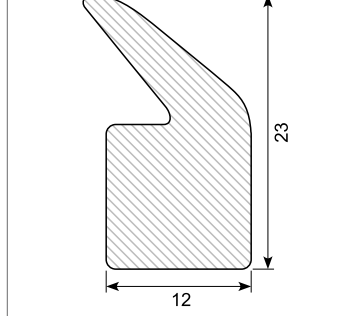
<p><b>36.K695</b> *</p>  <p>Color: Black</p>	<p><b>36.K697</b> *</p>  <p>Color: Black</p>	<p><b>36.K698</b> *</p>  <p>Color: Black</p>	<p><b>36.K852</b> *</p>  <p>Color: Black</p>
<p><b>36.K853</b> *</p>  <p>Color: Black</p>	<p><b>36.3351</b> *</p>  <p>Material: EPDM, black Hardness: SH 14 - 16 / density 0,38 - 0,4 Min. order: 500 m</p>	<p><b>36.3354</b> *</p>  <p>Material: NR, dark grey Hardness: SH 16 - 20 density 0,4 Min. order: 2.400 m</p>	<p><b>36.3813</b></p>  <p>Material: EPDM, dark grey Hardness: SH 16 - 20 density 0,4 - 0,45</p>
<p><b>36.B380</b></p>  <p>Material: EPDM Length: 3 m</p>	<p><b>36.3315</b></p>  <p>Material: EPDM, black Hardness: SH 18 - 20 density 0,45 - 0,55</p>	<p><b>36.3504</b></p>  <p>Material: EPDM, dark grey Hardness: SH 14 - 16 density 0,38 - 0,42</p>	<p><b>36.3881 / 36.3881S</b> *</p>  <p>Material: EPDM, grey / black Hardness: SH 16 - 20 density 0,4 - 0,5 36.3881S *: Black</p>
<p><b>36.14044</b> *</p>  <p>Material: EPDM Min. order: 500 m</p>	<p><b>36.3704</b></p>  <p>Material: NR, dark grey Hardness: SH 20 - 25 density 0,55 - 0,65</p>	<p><b>30.13144XX</b></p>  <p>Material: EPDM With adhesive</p>	<p><b>36.3882</b></p>  <p>Material: CR, black</p>

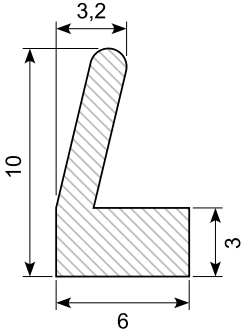
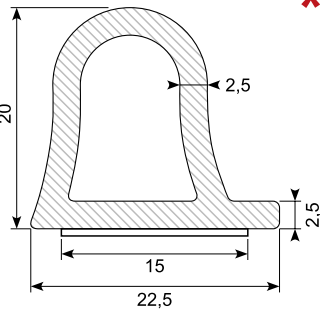
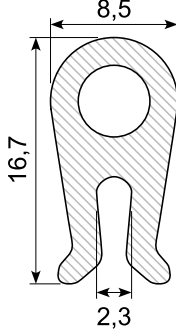
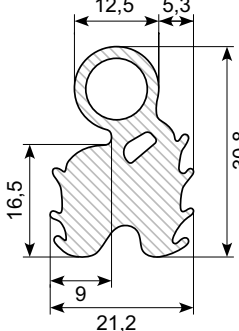
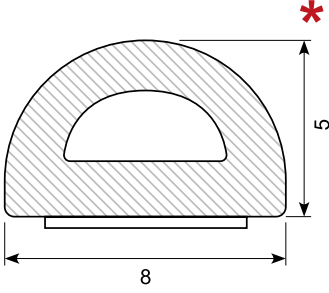
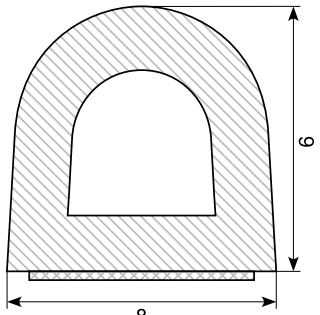
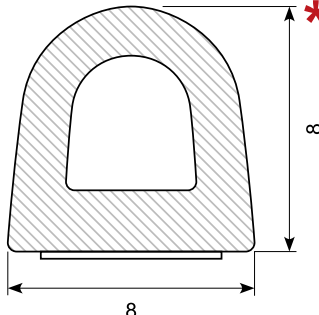
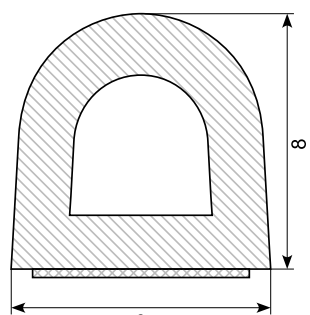
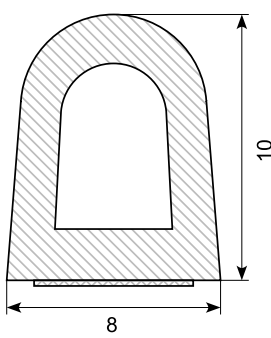
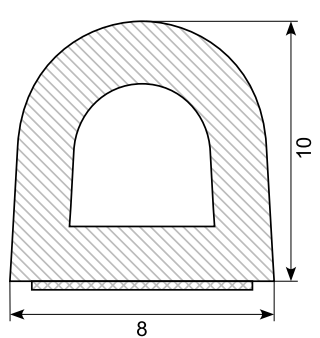
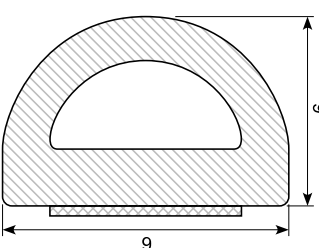
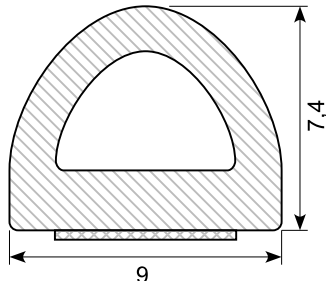
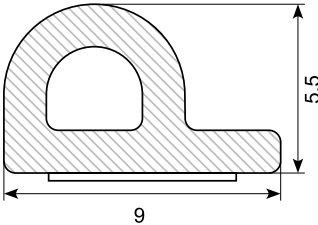
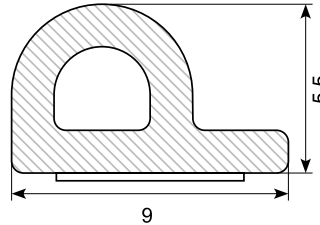
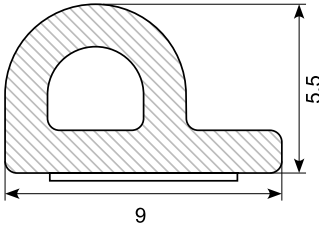
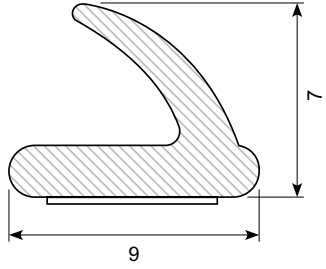

# Svampegummi / Sponge rubber

<p><b>36.3897</b></p>  <p>Material: EPDM, light grey</p>	<p><b>30.13315</b> *</p>  <p>Hardness: Density 0,7 With adhesive Min. order: 1.000 m</p>	<p><b>30.9884S</b> *</p>  <p>Material: EPDM Min. order: 3.000 m</p>	<p><b>30.E368</b></p>  <p>Material: EPDM, black</p>
<p><b>36.730805H</b> *</p>  <p>Material: EPDM, white Density: 0,25 - 0,40 With adhesive Min. order: 21.600 m</p>	<p><b>36.9086S</b></p>  <p>Material: EPDM, black With adhesive</p>	<p><b>36.730808</b> *</p>  <p>Material: EPDM, black Density: 0,25 - 0,35 With adhesive Min. order: 21.600 m</p>	<p><b>36.9088S</b></p>  <p>Material: EPDM, black With adhesive</p>
<p><b>36.730810</b></p>  <p>Material: EPDM, black Density: 0,35 - 0,45 With adhesive</p>	<p><b>36.90810</b></p>  <p>Material: EPDM, black Density: 0,35 - 0,45 With adhesive</p>	<p><b>36.730906 / 36.730906H</b> *</p>  <p>Material: EPDM, black / white Density: 0,25 - 0,35 With adhesive 36.730906H: min. order: 4.800 m</p>	<p><b>36.730907 / 36.730907G / 36.730907H</b></p>  <p>Material: EPDM, black / light grey / white Density: 0,25 - 0,35 With adhesive</p>
<p><b>36.730955</b></p>  <p>Material: EPDM, black Density: 0,25 - 0,35 With adhesive</p>	<p><b>36.730955G/36.730955H/36.730955B</b></p>  <p>Material: EPDM, grey/white/brown Density: 0,25 - 0,35</p>	<p><b>36.80955S</b></p>  <p>Material: EPDM, black With adhesive</p>	<p><b>36.740907H</b> *</p>  <p>Material: EPDM, white Density: 0,35 - 0,45 With adhesive Min. order: 21.600 m</p>

# Svampegummi / Sponge rubber

36.731210 / 36.731210H	36.731412D	36.732115	36.92117
Material: EPDM, <b>black / white</b> Density: 0,25 - 0,35 <b>With yellow adhesive</b>	Material: EPDM, black Density: 0,25 - 0,35 <b>With adhesive</b>	Material: EPDM, black Density: 0,45 - 0,55 <b>With adhesive</b>	Material: EPDM, black <b>With adhesive</b>

## Skaffevarer - Svampegummiprofiler / Special order - Sponge rubber profiles

Vi kan skaffe svampegummiprofiler i forskellige udformninger.

Herunder ser du et lille udvalg. På vores hjemmeside kan du finde et katalog med endnu flere muligheder. Se hele kataloget for svampegummiskaffevarer ved at scanne QR-koden. Pris og varenummer på forespørgsel.

We can get sponge rubber profiles in different shapes. Here you will find a small selection. On our webpage you can find a catalog with even more possibilities. Scan the QR-code to see the catalog. Price and product number on request.

