

## Зміст

---

vt67bb	2
vt67cb	4
vt67db	6
vt67dc	8
vt67eb	10
vt67ec	12

VT67BB W - B10 - B10 - 1 R 00 - A 1 - M1 -

Series- SAE B 2 bolts  
Mounting flange J744c

Use for severe duty shaft only

Cam ring for "P1" and "P2"

Volumetric displacement  $\text{cm}^3/\text{rev}$  ( $\text{in}^3/\text{rev}$ )

B02 = 5.8 (0.35)	B09 = 28.0 (1.71)
B03 = 9.8 (0.60)	B10 = 31.8 (1.94)
B04 = 12.8 (0.78)	B11 = 34.9 (2.13)
B05 = 15.9 (0.97)	B12 = 40.9 (2.50)
B06 = 19.8 (1.21)	B14 = 45.1 (2.75)
B07 = 22.5 (1.37)	B15 = 50.0 (3.05)
B08 = 24.9 (1.52)	

Type of shaft

- 1 - keyed (no SAE)
- 3 - splined (SAE BB)
- 5 - splined (SAE B)

Type of shaft- W version

- 2 - keyed (SAE BB)

Modifications

Mounting W/connection variables

- 11 = 4 bolts SAE flanges (J518c) UNC thread
- M1 = 4 bolts SAE flanges (J518c) Metric thread

Seal class

- 1 - S1 (for mineral oil)
- 4 - S4 (for fire resistant fluids)
- 5 - S5 (for mineral oil and fire resistant fluids)

Design letter

Porting combination (see page BM-1-5)

- 00 - standard

Direction of rotation (view on shaft end)

- R - clockwise
- L - counter-clockwise

## INTERNAL LEAKAGE ( TYPICAL )

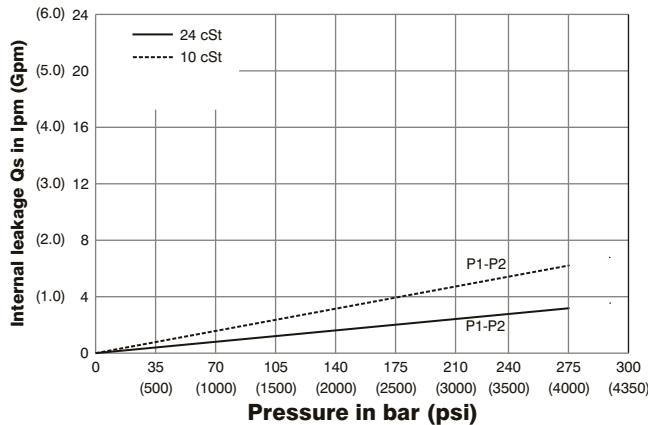

Do not operate pump more than 5 seconds at any speed or viscosity if internal leakage is more than 50% of theoretical flow.  
Total leakage is the sum of each section loss at its operating conditions.

## NOISE LEVEL ( TYPICAL ) VT67BB- B10-B03

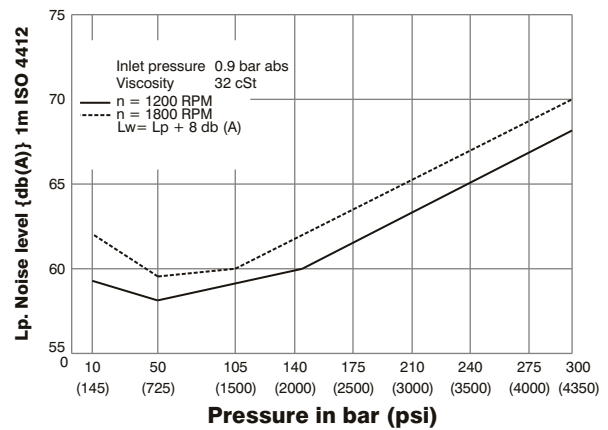

Double pump noise level is given with each section discharging at the pressure noted on the curve.

## HYDROMECHANICAL POWER LOSS ( TYPICAL )

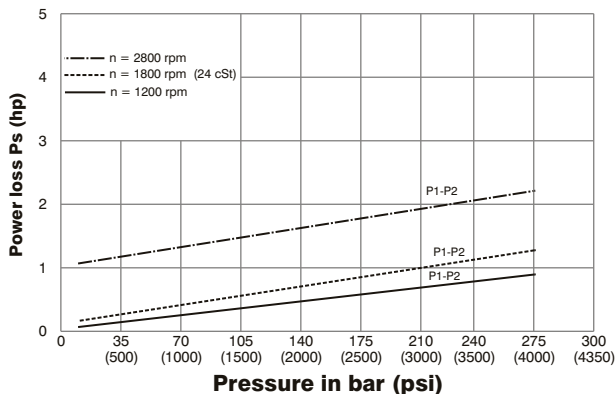

Total hydromechanical power loss is the sum of each section at its operating conditions.

## PERMISSIBLE RADIAL LOAD

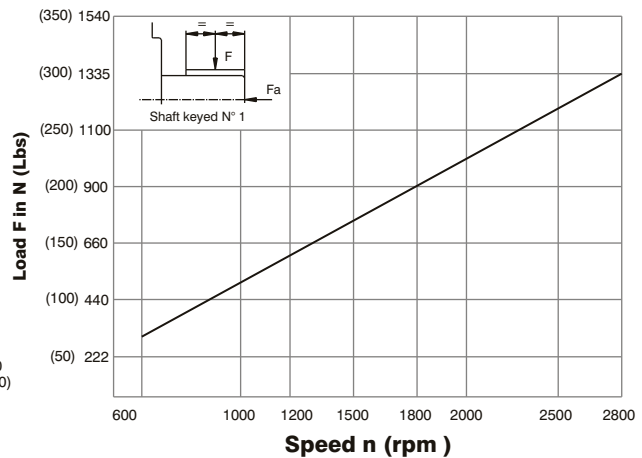

Maximum permissible axial load  $F_a = 800\text{N}$  (180 lbs)

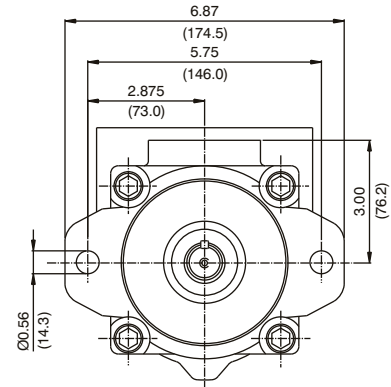
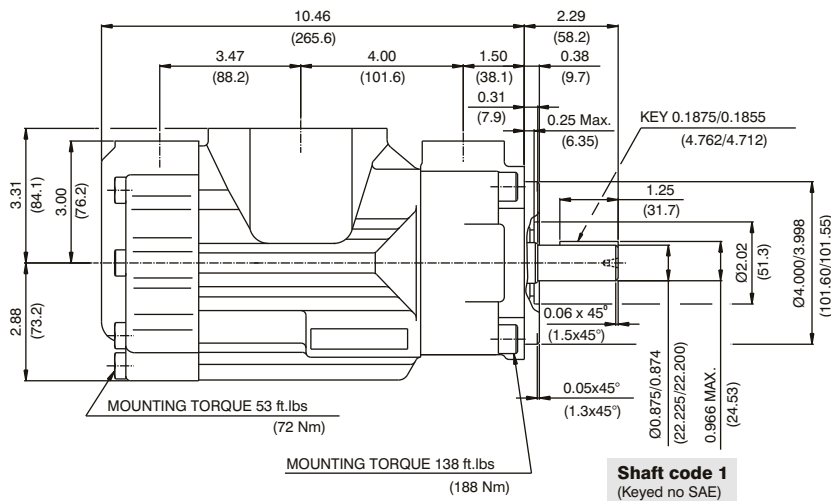
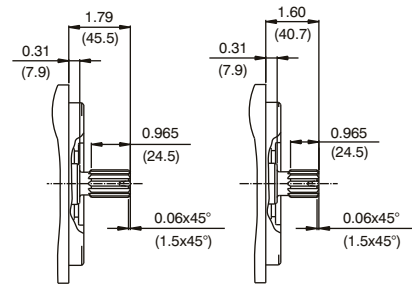
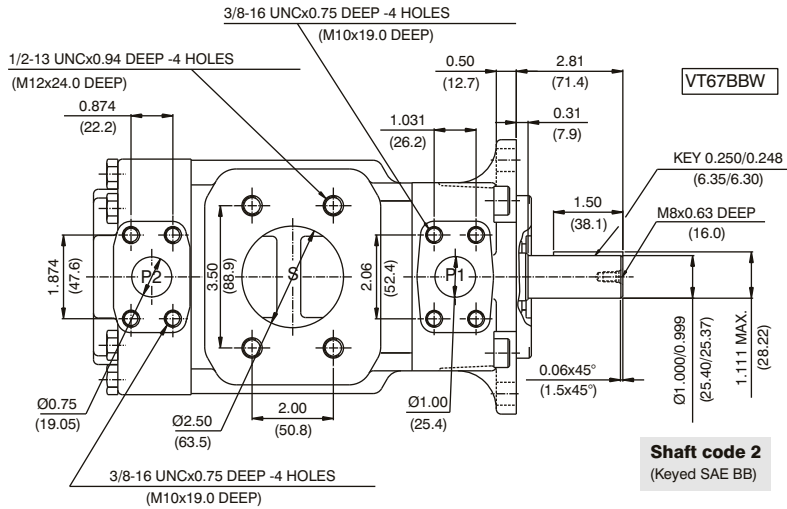

Shaft torque limits in <sup>3</sup> /rev x psi (ml/rev x bar)	
Shaft	Vp x p max. (P1+P2)
1	12666 (14300)
2	18972 (21420)
3	28937 (32670)
5	18246 (20600)

Pressure port	Series	Volumetric Displacement Vp		Flow q & n = 1800 rpm						Input power p & n = 1800 rpm					
		in <sup>3</sup> /rev		p = 0 bar (0 psi)		p = 140 bar (2000 psi)		p = 300 bar (4350 psi)		p = 7 bar (100 psi)		p = 140 bar (2000 psi)		p = 300 bar (4350 psi)	
		cm <sup>3</sup> /rev	gpm	lpm	gpm	lpm	gpm	lpm	hp	kw	hp	kw	hp	kw	
<b>P1 &amp; P2</b>	B02	0.35	5.7	2.76	10.4	2.33	8.8	1.80	6.8	0.74	0.55	4.02	2.99	8.10	6.40
	B03	0.60	9.8	4.66	17.6	4.23	15.9	3.70	14.0	0.85	0.63	6.24	4.65	12.93	10.25
	B04	0.78	12.8	6.09	23.0	5.66	21.4	5.13	19.4	0.94	0.70	7.90	5.89	16.55	13.13
	B05	0.97	15.9	7.56	28.6	7.13	26.9	6.60	25.0	1.02	0.76	9.62	7.17	20.29	16.12
	B06	1.21	19.8	9.42	35.6	8.99	33.9	8.46	32.0	1.13	0.84	11.79	8.79	25.00	19.88
	B07	1.37	22.5	10.70	40.4	10.27	38.8	9.74	36.8	1.20	0.89	13.29	9.91	28.26	22.47
	B08	1.52	24.9	11.84	44.7	11.41	43.1	10.88	41.1	1.27	0.94	14.62	10.90	31.15	24.78
	B09	1.71	28.0	13.31	50.3	12.87	48.6	12.35	47.0	1.36	1.01	16.35	12.19	34.92	27.77
	B10	1.94	31.8	15.12	57.2	14.69	55.5	14.16	53.5	1.46	1.11	18.45	13.75	39.48	31.42
	B11 <sup>1)</sup>	2.13	34.9	16.64	62.9	16.19	61.2	15.68	59.3	1.55	1.15	20.17	15.04	43.22	32.22
	B12 <sup>1)</sup>	2.50	40.9	19.50	73.7	19.07	72.1	18.54	70.1	1.72	1.28	23.55	17.56	50.58	37.71
	B14 <sup>1)</sup>	2.75	45.1	21.40	80.8	20.95	79.2	20.44	77.0	1.83	1.36	25.80	19.23	55.48	41.37
	B15 <sup>1)</sup>	3.05	50.0	23.78	89.8	23.35	88.3	22.88	86.5	1.97	1.47	28.55	21.28	57.35	42.7

1) B11-B12-B14 = 300 bar (4350 psi) & B15 = 280 bar (4060 psi) max. int. And Max. Speed = 3000 rpm

VT67CB W - 012 - B08 - 1 R 00 - A 1 - 11 -

Series- SAE B 2 bolts  
Mounting flange J744c

Use for severe duty shaft only

Cam ring for "P1"

Volumetric displacement cm<sup>3</sup>/rev (in<sup>3</sup>/rev)

*003/B03 = 10.8 (0.66)	015/B15 = 50.5 (3.08)
005/B05 = 17.2 (1.05)	017/B17 = 58.3 (3.56)
006/B06 = 21.3 (1.30)	020/B20 = 63.8 (3.89)
008/B08 = 26.4 (1.61)	022/B22 = 70.3 (4.29)
010/B10 = 34.1 (2.08)	025/B25 = 79.3 (4.84)
012/B12 = 37.1 (2.26)	028/B28 = 88.8 (5.42)
014/B14 = 46.0 (2.81)	031/B31 = 100.0 (6.10)

\*'0' - Uni - directional 'B' - Bi - directional

Cam ring for "P2"

Volumetric displacement cm<sup>3</sup>/rev (in<sup>3</sup>/rev)

B02 = 5.7 (0.35)	B09 = 28.0 (1.71)
B03 = 9.8 (0.60)	B10 = 31.8 (1.94)
B04 = 12.8 (0.78)	B11 = 34.9 (2.13)
B05 = 15.9 (0.97)	B12 = 40.9 (2.50)
B06 = 19.8 (1.21)	B14 = 45.1 (2.75)
B07 = 22.5 (1.37)	B15 = 50.0 (3.05)
B08 = 24.9 (1.52)	

Type of shaft

- 1- keyed (no SAE)                      W version
- 3- splined (SAE BB)                  2- keyed (SAE BB)
- 5- splined (SAE B)

Modifications

Mounting W/connection variables

P1=1" P2=3/4" S=2 1/2"	
UNC	METRIC
11	M1

Seal class

- 1 - S1 (for mineral oil)
- 4 - S4 (for fire resistant fluids)
- 5 - S5 (for mineral oil and fire resistant fluids)

Design letter

Porting combination (see page BM-1-5)

00 - standard

Direction of rotation  
(view on shaft end)

- R - clockwise
- L - counter-clockwise

## INTERNAL LEAKAGE ( TYPICAL )

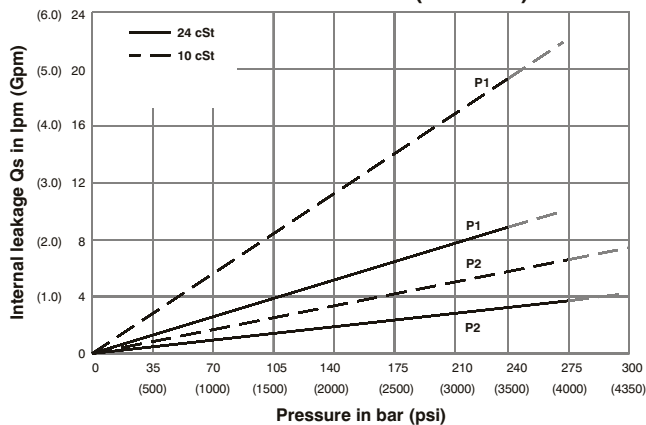

Do not operate pump more than 5 seconds at any speed or viscosity if internal leakage is more than 50% of theoretical flow.  
Total leakage is the sum of each section loss at its operating conditions.

## HYDROMECHANICAL POWER LOSS ( TYPICAL )

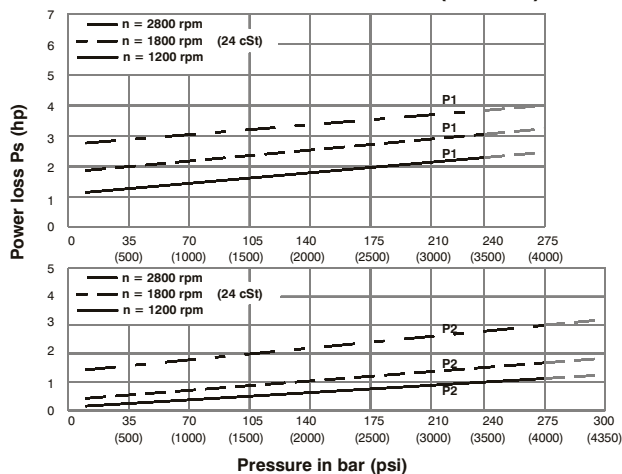

Total hydromechanical power loss is the sum of each section at its operating conditions.

## NOISE LEVEL ( TYPICAL )

VT67CB- 014-B03

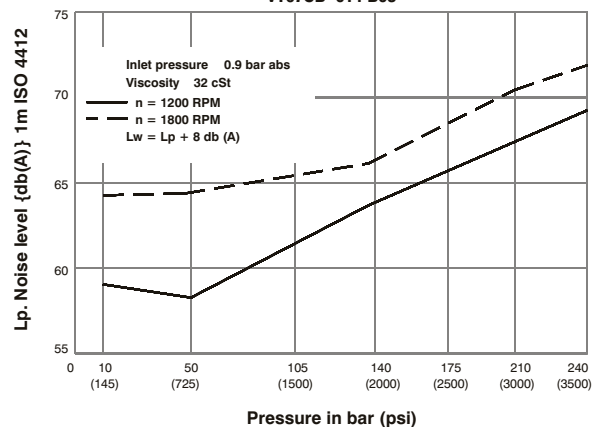

Double pump noise level is given with each section discharging at the pressure noted on the curve.

## PERMISSIBLE RADIAL LOAD

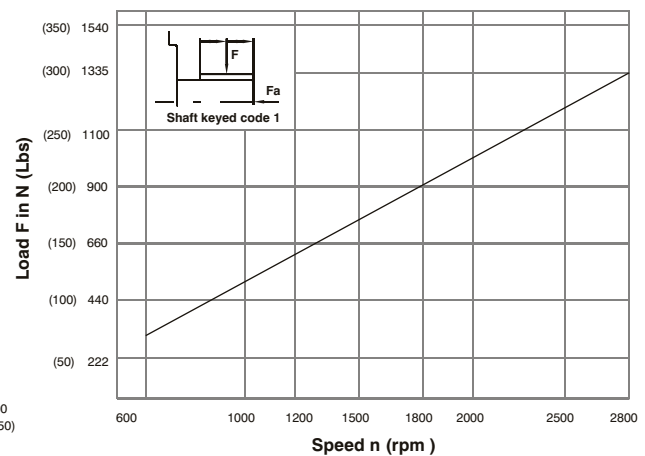

Maximum permissible axial load Fa = 800N (180 lbs)

DP

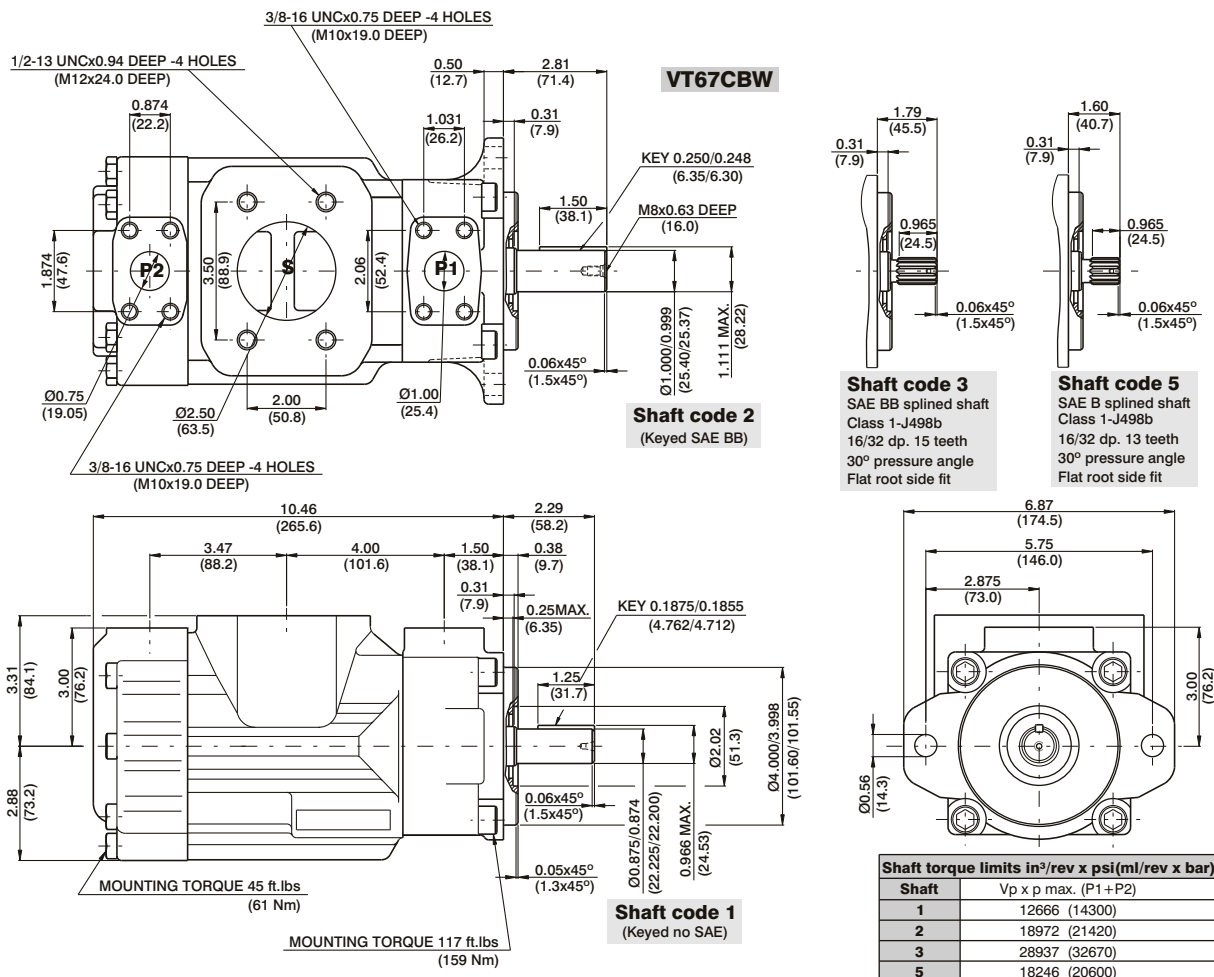

## OPERATING CHARACTERISTICS - TYPICAL (24 cST) (Input power p (KW) for one cartridge only)

Pressure port	Series	Volumetric Displacement Vp		Flow q & n = 1800 rpm						Input power p & n = 1800 rpm					
		p = 0 bar (0 psi)		p = 140 bar (2000 psi)		p = 275 bar (4000 psi)		p = 7 bar (100 psi)		p = 140 bar (2000 psi)		p = 275 bar (4000 psi)			
		in <sup>3</sup> /rev	cm <sup>3</sup> /rev	gpm	lpm	gpm	lpm	gpm	lpm	hp	kw	hp	kw	hp	kw
P1	003	0.66	10.8	5.14	19.6	3.85	14.6	--	--	2.11	1.57	8.45	6.30	--	--
	005	1.05	17.2	8.18	30.9	6.89	26.0	5.68	21.5	2.29	1.70	12.00	8.94	19.81	14.77
	006	1.30	21.3	10.13	38.3	8.84	33.4	7.63	28.8	2.40	1.78	14.28	10.64	23.79	17.74
	008	1.61	26.4	12.55	47.4	11.26	42.6	10.05	37.9	2.54	1.89	17.11	12.75	28.75	21.43
	010	2.08	34.1	16.22	61.3	14.93	56.4	13.71	51.8	2.76	2.06	21.38	15.94	36.22	27.00
	012	2.26	37.1	17.64	66.7	16.35	61.8	15.14	57.2	2.84	2.11	23.05	17.18	39.14	29.18
	014	2.81	46.0	21.88	82.7	20.59	77.8	19.37	73.2	3.09	2.30	27.99	20.87	47.78	35.62
	015	3.08	50.5	23.99	90.7	22.83	86.3	21.56	81.5	3.21	2.40	30.30	22.60	51.36	38.30
	017	3.56	58.3	27.73	104.8	26.44	99.9	25.22	95.3	3.43	2.55	34.81	25.95	59.73	44.54
	020	3.89	63.8	30.34	114.7	29.05	109.8	27.84	105.2	3.58	2.66	37.86	28.23	65.07	48.52
	022	4.29	70.3	33.43	126.4	32.14	121.5	30.93	116.9	3.76	2.80	41.47	30.92	71.38	53.22
	025 <sup>1)</sup>	4.84	79.3	37.71	142.5	36.42	137.6	35.21	133.1	4.01	2.99	46.46	34.64	80.12	59.74
	028 <sup>1,2)</sup>	5.42	88.8	42.23	159.6	40.94	154.7	40.32	152.4	4.27	3.18	51.74	38.58	76.73	57.22
031 <sup>1,2)</sup>	6.10	100.0	47.56	179.7	46.27	174.9	45.65	172.5	4.58	3.41	57.95	43.21	86.06	64.17	
P2	B02	0.35	5.7	2.76	10.4	2.33	8.8	1.80	6.8	0.74	0.55	4.02	2.99	8.10	6.40
	B03	0.60	9.8	4.66	17.6	4.23	15.9	3.70	14.0	0.85	0.63	6.24	4.65	12.93	10.25
	B04	0.78	12.8	6.09	23.0	5.66	21.4	5.13	19.4	0.94	0.70	7.90	5.89	16.55	13.13
	B05	0.97	15.9	7.56	28.6	7.13	26.9	6.60	25.0	1.02	0.76	9.62	7.17	20.29	16.12
	B06	1.21	19.8	9.42	35.6	8.99	33.9	8.46	32.0	1.13	0.84	11.79	8.79	25.00	19.88
	B07	1.37	22.5	10.70	40.4	10.27	38.8	9.74	36.8	1.20	0.89	13.29	9.91	28.26	22.47
	B08	1.52	24.9	11.84	44.7	11.41	43.1	10.88	41.1	1.27	0.94	14.62	10.90	31.15	24.78
	B09	1.71	28.0	13.31	50.3	12.87	48.6	12.35	47.0	1.36	1.01	16.35	12.19	34.92	27.77
	B10	1.94	31.8	15.12	57.2	14.69	55.5	14.16	53.5	1.46	1.11	18.45	13.75	39.48	31.42
	B11 <sup>3)</sup>	2.13	34.9	16.64	62.9	16.19	61.2	15.68	59.3	1.55	1.15	20.17	15.04	43.22	32.22
	B12 <sup>3)</sup>	2.50	40.9	19.50	73.7	19.07	72.1	18.54	70.1	1.72	1.28	23.55	17.56	50.58	37.71
	B14 <sup>3)</sup>	2.75	45.1	21.40	80.8	20.95	79.2	20.44	77.0	1.83	1.36	25.80	19.23	55.48	41.37
	B15 <sup>3)</sup>	3.05	50.0	23.78	89.8	23.35	88.3	22.88	86.5	1.97	1.47	28.55	21.28	57.35	42.76

1) 025-028-031 = 2500 rpm max. 2) 028-031 = 210 bar (3000 psi) max. int  
3) B11-B12-B14 = 300 bar (4350 psi) & B15 = 280 bar (4060 psi) max. int. And Max. Speed = 3000 rpm

--- Not to use because internal leakage greater than 50 % theoretical flow.

**VT67DB W - 038 - B08 1 R 00 - A 1 M1 -**

**Series-** SAE C 2 bolts  
Mounting flange J744c

**severe duty shaft only**

**Cam ring for "P1"**

Volumetric displacement cm<sup>3</sup>/rev (in<sup>3</sup>/rev)

*014/B14 = 47.6 (2.90)	035/B35 = 111.0 (6.77)
017/B17 = 58.2 (3.55)	038/B38 = 120.3 (7.34)
020/B20 = 66.0 (4.03)	042/B42 = 136.0 (8.30)
024/B24 = 79.5 (4.85)	045/B45 = 145.7 (8.89)
028/B28 = 89.7 (5.47)	050/B50 = 158.0 (9.64)
031/B31 = 98.3 (6.00)	061/B61 = 190.5 (11.62)

\*0' - Uni-directional B' - Bi-directional

**Cam ring for "P2"**

Volumetric displacement cm<sup>3</sup>/rev (in<sup>3</sup>/rev)

B02 = 5.7 (0.35)	B09 = 28.0 (1.71)
B03 = 9.8 (0.60)	B10 = 31.8 (1.94)
B04 = 12.8 (0.78)	B11 = 34.9 (2.13)
B05 = 15.9 (0.97)	B12 = 40.9 (2.50)
B06 = 19.8 (1.21)	B14 = 45.1 (2.75)
B07 = 22.5 (1.37)	B15 = 50.0 (3.05)
B08 = 24.9 (1.52)	

**Modifications**

**Mounting W/connection variables**

P1=1-1/4" P2=3/4" S=3"	
UNC	METRIC
11	M1

**Seal class**

- 1 - S1 (for mineral oil)
- 4 - S4 (for fire resistant fluids)
- 5 - S5 (for mineral oil and fire resistant fluids)

**Design letter**

**Porting combination (see page BM-1-5)**

00 - standard

**Direction of rotation (view on shaft end)**

- R - clockwise
- L - counter-clockwise

**Sever duty (VT67DBW only)**

5 - keyed (no SAE)

**Type of shaft**

- 1 - keyed (SAE C)
- 2 - keyed (no SAE)
- 3 - splined (SAE C)
- 4 - splined (no SAE)

## INTERNAL LEAKAGE ( TYPICAL )

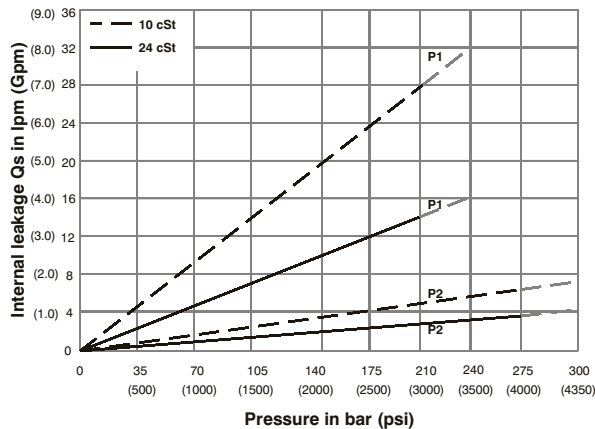

Do not operate pump more than 5 seconds at any speed or viscosity if internal leakage is more than 50% of theoretical flow. Total leakage is the sum of each section loss at its operating conditions.

## NOISE LEVEL ( TYPICAL )

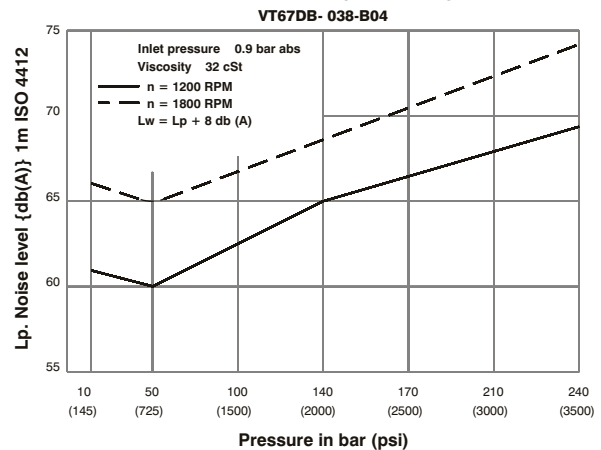

Double pump noise level is given with each section discharging at the pressure noted on the curve.

## HYDROMECHANICAL POWER LOSS ( TYPICAL )

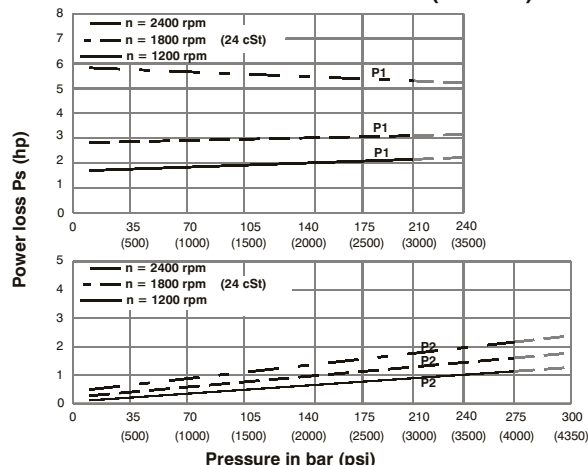

Total hydromechanical power loss is the sum of each section at its operating conditions.

## PERMISSIBLE RADIAL LOAD

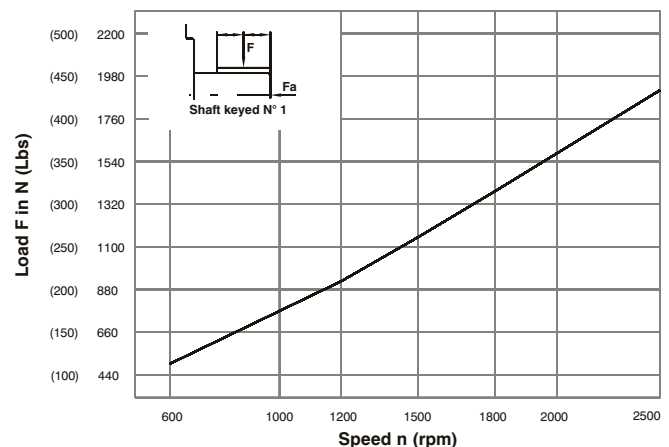

Maximum permissible axial load Fa = 1200 N (270 Lbs)

# HIGH PERFORMANCE VANE PUMP VT67DB

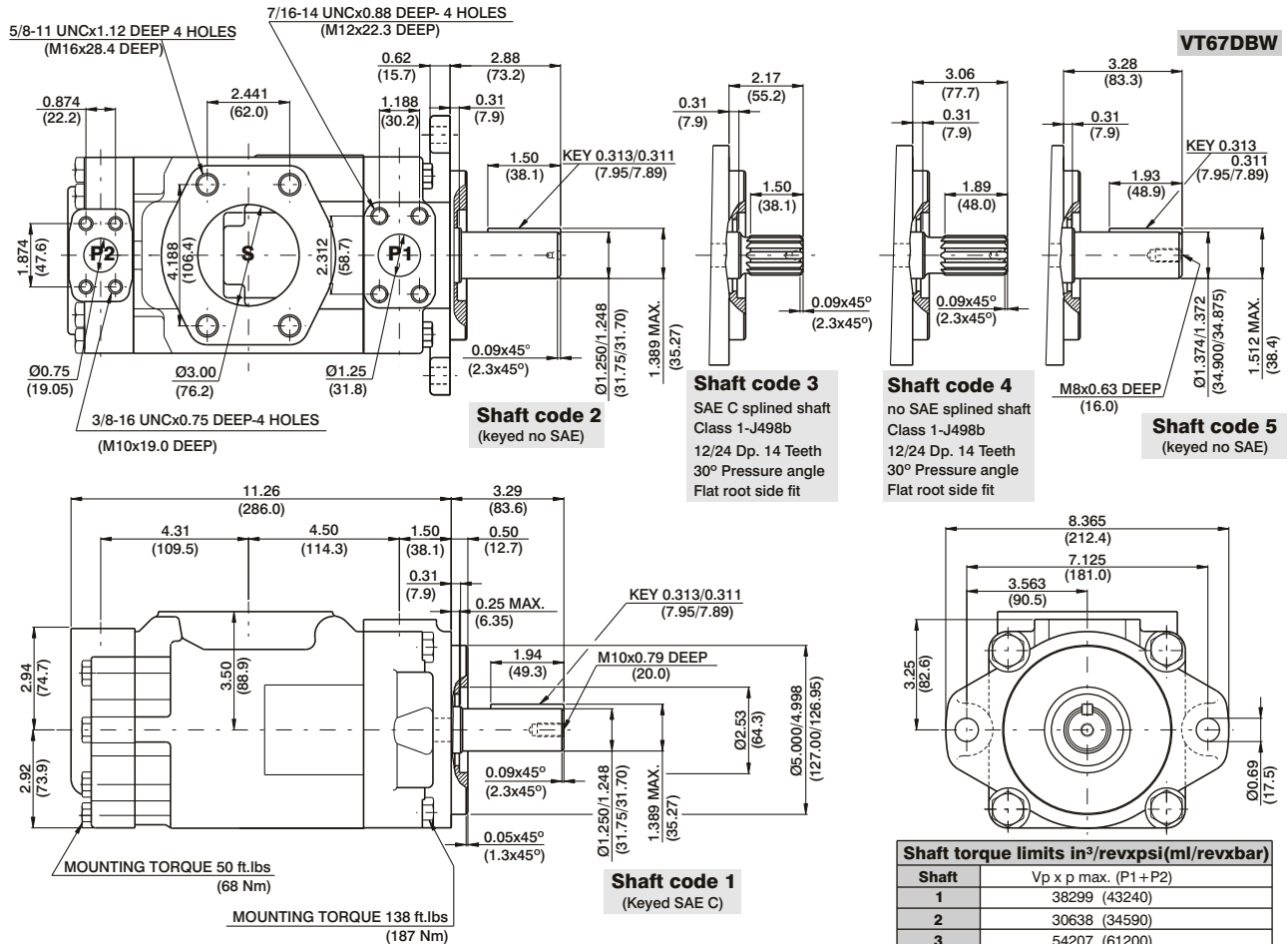

Shaft torque limits in <sup>3</sup> /revpsi(ml/revxbar)	
Shaft	Vp x p max. (P1+P2)
1	38299 (43240)
2	30638 (34590)
3	54207 (61200)
4	54207 (61200)
5	49247 (55600)

## OPERATING CHARACTERISTICS - TYPICAL (24 cST) (Input power p (KW) for one cartridge only)

Pressure port	Series	Volumetric Displacement Vp		Flow q & n = 1800 rpm						Input power p & n = 1800 rpm					
		in <sup>3</sup> /rev	cm <sup>3</sup> /rev	p = 0 bar (0 psi)		p = 140 bar (2000 psi)		p = 240 bar (3500 psi)		p = 7 bar (100 psi)		p = 140 bar (2000 psi)		p = 240 bar (3500 psi)	
				gpm	lpm	gpm	lpm	gpm	lpm	hp	kw	hp	kw	hp	kw
P1	014	2.90	47.6	22.64	85.0	20.46	77.4	18.8	71.1	4.02	2.99	29.31	21.85	49.34	36.79
	017	3.55	58.2	23.1	87.3	20.6	78.0	18.99	71.8	3.35	2.5	29.77	22.2	49.62	37.0
	020	4.03	66.0	31.39	118.6	29.29	101.4	27.57	104.2	4.53	3.38	39.52	29.47	67.21	50.11
	024	4.85	79.5	37.81	142.8	35.63	134.6	33.99	128.5	4.91	3.66	47.02	35.06	80.32	59.89
	028	5.47	89.7	42.66	161.3	40.48	153.0	38.84	146.8	5.19	3.87	52.68	39.28	90.23	67.28
	031	6.00	98.3	46.75	176.7	44.57	168.5	42.93	162.3	5.43	4.09	57.45	42.84	98.58	73.51
	035	6.77	111.0	52.79	199.6	50.61	191.3	48.97	184.1	5.78	4.31	64.50	48.09	110.91	82.70
	038	7.34	120.3	57.21	216.3	55.03	208.1	53.39	201.8	6.04	4.50	69.66	51.94	111.94	83.47
	042 <sup>1)</sup>	8.30	136.0	64.68	244.5	62.50	236.3	60.86	230.1	6.47	4.83	78.37	58.44	135.19	100.81
	045 <sup>1)</sup>	8.89	145.7	69.29	261.9	67.11	253.7	65.47	247.5	6.74	5.02	83.75	62.45	144.61	107.83
	050 <sup>1,2)</sup>	9.64	158.0	75.14	284.1	72.96	275.8	71.78	271.3	7.08	5.27	90.58	67.54	134.54	100.32
061 <sup>1,2)</sup>	11.62	190.4	75.6	285.8	73.54	278.0	--	--	7.37	5.50	97.49	72.69	--	--	
P2				p = 0 bar (0 psi)	p = 140 bar (2000 psi)	p = 300 bar (4350 psi)	p = 7 bar (100 psi)	p = 140 bar (2000 psi)	p = 300 bar (4350 psi)						
	B02	0.35	5.8	2.76	10.4	2.33	8.8	1.80	6.8	0.74	0.55	4.02	2.99	8.10	6.40
	B03	0.60	9.8	4.66	17.6	4.23	15.9	3.70	14.0	0.85	0.63	6.24	4.65	12.93	10.25
	B04	0.78	12.8	6.09	23.0	5.66	21.4	5.13	19.4	0.94	0.70	7.90	5.89	16.55	13.13
	B05	0.97	15.9	7.56	28.6	7.13	26.9	6.60	25.0	1.02	0.76	9.62	7.17	20.29	16.12
	B06	1.21	19.8	9.42	35.6	8.99	33.9	8.46	32.0	1.13	0.84	11.79	8.79	25.00	19.88
	B07	1.37	22.5	10.70	40.4	10.27	38.8	9.74	36.8	1.20	0.89	13.29	9.91	28.26	22.47
	B08	1.52	24.9	11.84	44.7	11.41	43.1	10.88	41.1	1.27	0.94	14.62	10.90	31.15	24.78
	B09	1.71	28.0	13.31	50.3	12.87	48.6	12.35	47.0	1.36	1.01	16.35	12.19	34.92	27.77
	B10	1.94	31.8	15.12	57.2	14.69	55.5	14.16	53.5	1.46	1.11	18.45	13.75	39.48	31.42
	B11 <sup>4)</sup>	2.13	34.9	16.64	62.9	16.19	61.2	15.68	59.3	1.55	1.15	20.17	15.04	43.22	32.22
	B12 <sup>4)</sup>	2.50	40.9	19.50	73.7	19.07	72.1	18.54	70.1	1.72	1.28	23.55	17.56	50.58	37.71
	B14 <sup>4)</sup>	2.75	45.1	21.40	80.8	20.95	79.2	20.44	77.0	1.83	1.36	25.80	19.23	55.48	41.37
	B15 <sup>4)</sup>	3.05	50.0	23.78	89.8	23.35	88.3	22.88	86.5	1.97	1.47	28.55	21.28	57.35	42.76

1) 042-045-050-061=2200 RPM max. 2) 050=210 bar (3000 psi) max. int. 3) 061 = 120 bar (1740 psi) max. int, 061 = 80 bar (1160 psi) cont.

4) B11-B12-B14 = 300 bar (4350 psi) & B15 = 280 bar (4060 psi) max. int. And Max. Speed = 3000 rpm

## VT67DC W - 038 - B08 1 R 00 - A 1 M1 -

### Series

SAE B 2 bolts  
Mounting flange J744c

use for severe duty shaft only

### Camring for "P1"

Volumetric displacement  $\text{cm}^3/\text{rev}$  ( $\text{in}^3/\text{rev}$ )

B14=2.68 (43.9) B31=6.05 (99.1)  
B17=3.36 (55.0) B35=6.92 (113.4)  
B20=4.03 (66.0) B38=7.36 (120.6)  
B22=4.29 (70.3) B42=8.39 (137.5)  
B24=4.95 (81.1) 045=8.89 (145.7)  
B28=5.49 (89.9) 050=9.64 (157.9)

\* '0' - Uni - directional 'B' - Bi - directional

### Camring for "P2"

Volumetric displacement  $\text{cm}^3/\text{rev}$  ( $\text{in}^3/\text{rev}$ )

003/B03=0.66 (10.80) 015/B15=3.08 (50.50)  
005/B05=1.05 (17.20) 017/B17=3.56 (58.30)  
006/B06=1.30 (21.30) 020/B20=3.89 (63.80)  
008/B08=1.61 (26.40) 022/B22=4.29 (70.30)  
010/B10=2.08 (34.10) 025/B25=4.84 (79.30)  
012/B12=2.26 (37.10) 028/B28=5.42 (88.80)  
014/B14=2.81 (46.00) 031/B31=6.10 (100.00)

\* '0' - Uni - directional 'B' - Bi - directional

### Modifications

### Mounting W/connection variables

	UNC		METRIC	
	00	01	M0	M1
P2	1"	3/4"	1"	3/4"

### Seal class

- 1 - S1 (for mineral oil)
- 4 - S4 (for fire resistant fluids)
- 5 - S5 (for mineral oil and fire resistant fluids)

### Design letter

### Porting combination

00 - standard

### Direction of rotation (view on shaft end)

- R - clockwise
- L - counter-clockwise

### Type of shaft

- 1 - keyed (SAE C)
- 2 - keyed (no SAE)
- 3 - splined (SAE C)
- 4 - splined (no SAE)

### Sever duty (VT67DCW only)

5 - keyed (no SAE)

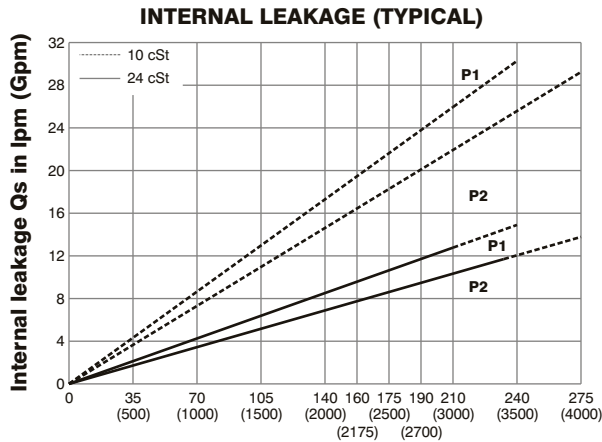

Do not operate pump more than 5 seconds at any speed or viscosity if internal leakage is more than 50% of theoretical flow. Total leakage is the sum of each section loss at its operating conditions.

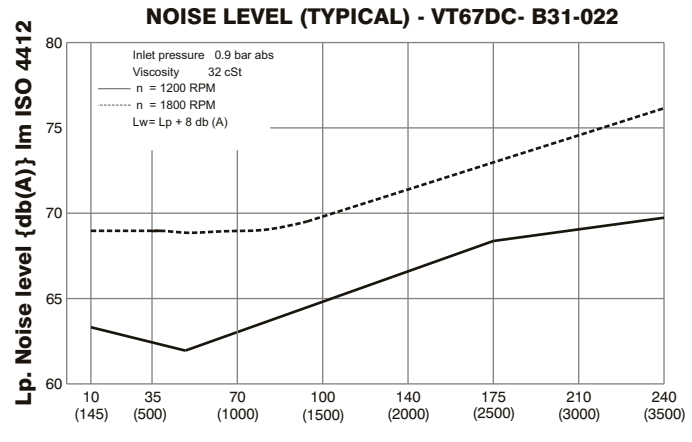

Double pump noise level is given with each section discharging at the pressure noted on the curve.

### HYDROMECAHNICAL POWER LOSS (TYPICAL)

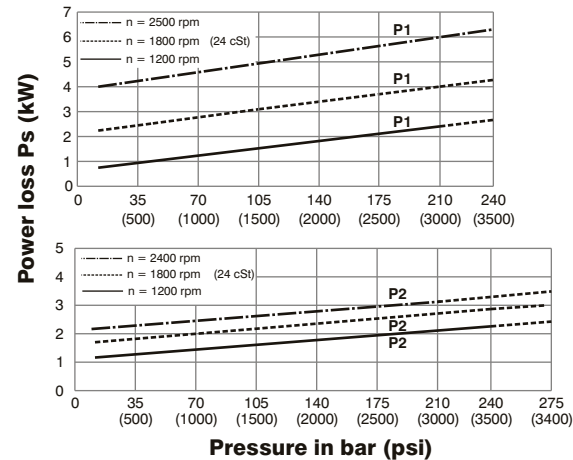

Total hydromechanical power loss is the sum of each section at its operating conditions.

### PERMISSIBLE RADIAL LOAD

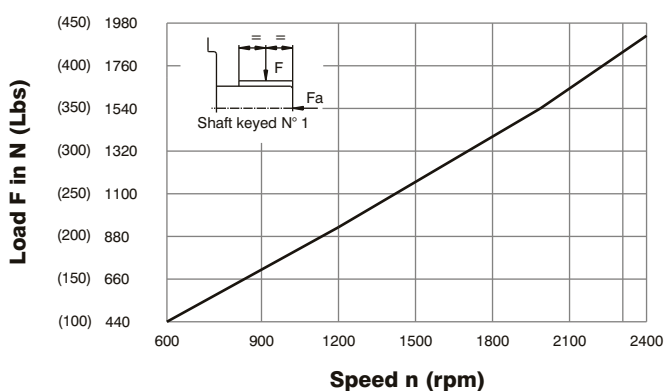

Maximum permissible axial load  $F_a = 1200 \text{ N}$  (270 Lbs)



# HIGH PERFORMANCE VANE PUMP VT67DC

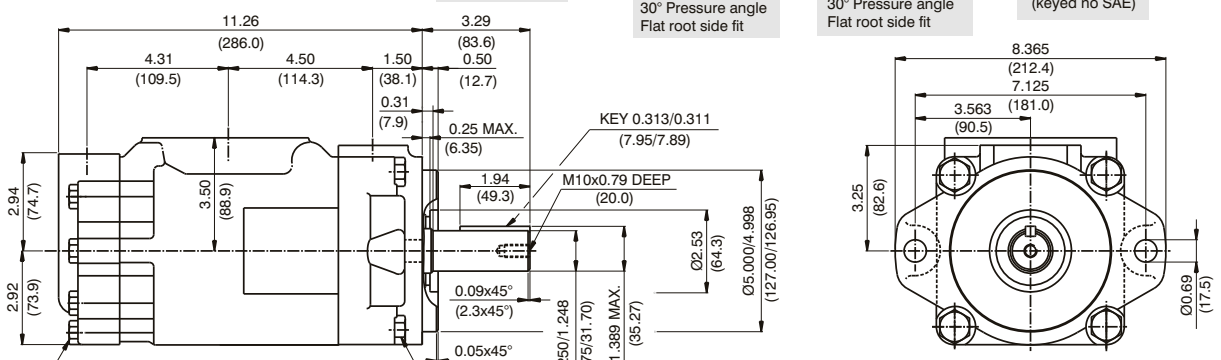
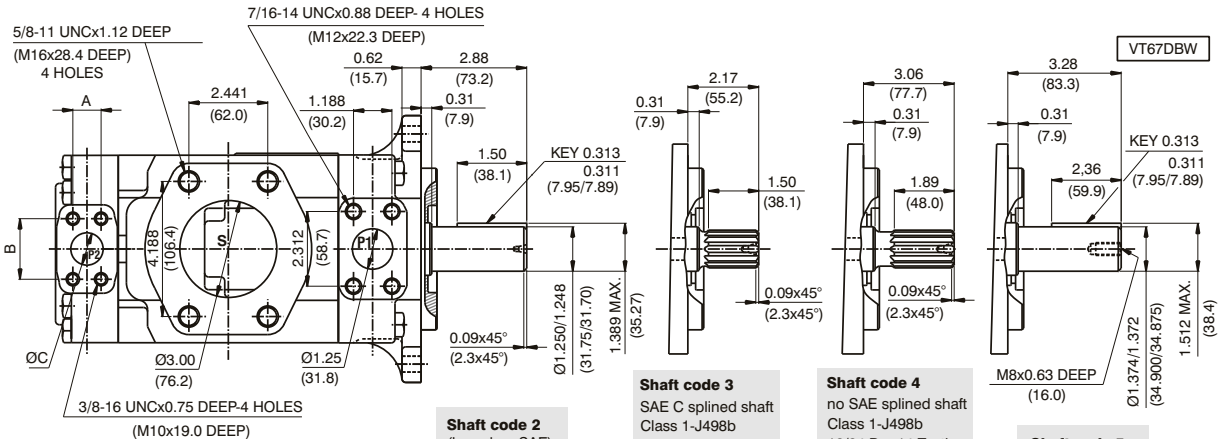

Shaft torque limits in <sup>3</sup> /rev/psi (ml/rev/bar)	
Shaft	Vp x p max. (P1+P2)
1	38299 (43240)
2	30638 (34590)
3	54207 (61200)
4	54207 (61200)
5	49247 (55600)

Alternate connect. variables	
	11 & M1
A	1.031 (26.2) 0.874 (22.2)
B	2.06 (52.4) 1.874 (47.6)
C	1.00 (25.4) 0.75 (19.05)

## OPERATING CHARACTERISTICS - TYPICAL (24 cST) (Input power p (KW) for one cartridge only)

Pressure port	Series	Volumetric Displacement Vp		Flow q & n = 1800 rpm						Input power p & n = 1800 rpm					
		in <sup>3</sup> /rev	cm <sup>3</sup> /rev	p = 0 bar (0 psi)	p = 140 bar (2000 psi)	p = 250 bar (3630 psi)	p = 7 bar (100 psi)	p = 140 bar (2000 psi)	p = 250 bar (3630 psi)	p = 7 bar (100 psi)	p = 140 bar (2000 psi)	p = 250 bar (3630 psi)			
P1	B14	2.68	43.9	20.92	79.1	19.18	72.5	17.81	67.3	3.46	2.6	27.77	20.7	47.03	35.07
	B17	3.36	55.0	26.16	98.8	24.41	92.3	23.04	87.0	3.77	2.8	33.88	25.3	57.71	43.03
	B20	4.03	66.0	31.39	118.6	29.64	112.0	28.27	106.8	4.07	3.0	39.98	29.8	68.39	50.99
	B22	4.29	70.3	33.43	126.4	31.69	119.8	30.32	104.6	4.19	3.1	42.37	31.6	72.57	54.11
	B24	4.95	81.1	38.57	145.8	36.82	139.2	35.45	134.0	4.49	3.4	48.36	36.1	83.06	61.93
	B28	5.49	89.9	42.80	161.8	41.06	155.2	39.69	150.0	4.74	3.5	53.30	39.7	91.70	68.38
	B31	6.05	99.1	47.18	178.3	45.43	171.7	44.06	166.5	4.99	3.7	58.41	43.6	100.63	75.03
	B35	6.92	113.4	53.93	203.9	52.18	197.2	50.81	192.0	5.39	4.0	66.29	49.4	114.42	85.32
	B38	7.36	120.6	57.35	216.8	55.61	210.2	54.24	204.9	5.59	4.2	70.28	52.4	121.42	90.54
	B42	8.39	137.5	65.39	247.2	63.65	240.6	62.28	235.4	6.05	4.5	79.66	59.4	137.83	102.77
	045	8.89	145.7	69.29	262.0	67.11	253.6	65.31	246.8	6.74	5.0	83.75	62.4	145.79	108.71
050	9.64	157.9	75.14	284.0	72.96	275.8	71.78 <sup>1)</sup>	271.3 <sup>1)</sup>	7.08	5.3	90.58	67.5	134.50 <sup>1)</sup>	100.3 <sup>1)</sup>	
P2				p=0 bar (0 psi)	p=140 bar (2000 psi)	p=275 bar (4000 psi)	p=275 bar (4000 psi)	p=275 bar (4000 psi)	p=7 bar (100 psi)	p=140 bar (2000 psi)	p=275 bar (4000 psi)	p=7 bar (100 psi)	p=140 bar (2000 psi)	p=275 bar (4000 psi)	
	003	0.66	10.8	5.14	19.6	3.85	14.6	--	--	2.11	1.57	8.45	6.30	--	
	005	1.05	17.2	8.18	30.9	6.89	26.0	5.68	21.5	2.29	1.70	12.00	8.94	19.81	
	006	1.30	21.3	10.13	38.3	8.84	33.4	7.63	28.8	2.40	1.78	14.28	10.64	23.79	
	008	1.61	26.4	12.55	47.4	11.26	42.6	10.05	37.9	2.54	1.89	17.11	12.75	28.75	
	010	2.08	34.1	16.22	61.3	14.93	56.4	13.71	51.8	2.76	2.06	21.38	15.94	36.22	
	012	2.26	37.1	17.64	66.7	16.35	61.8	15.14	57.2	2.84	2.11	23.05	17.18	39.14	
	014	2.81	46.0	21.88	82.7	20.59	77.8	19.37	73.2	3.09	2.30	27.99	20.87	47.78	
	015	3.08	50.5	23.99	90.7	22.83	86.3	21.56	81.5	3.21	2.40	30.30	22.60	51.36	
	017	3.56	58.3	27.73	104.8	26.44	99.9	25.22	95.3	3.43	2.55	34.81	25.95	59.73	
	020	3.89	63.8	30.34	114.7	29.05	109.8	27.84	105.2	3.58	2.66	37.86	28.23	65.07	
	022	4.29	70.3	33.43	126.4	32.14	121.5	30.93	116.9	3.76	2.80	41.47	30.92	71.38	
	025	4.84	79.3	37.71	142.5	36.42	137.6	35.21	133.1	4.01	2.99	46.46	34.64	80.12	
	028	5.42	88.8	42.23	159.6	40.94	154.7	40.32 <sup>2)</sup>	152.4 <sup>2)</sup>	4.27	3.18	51.74	38.58	76.73 <sup>2)</sup>	
031	6.10	100.0	47.56	179.7	46.27	174.9	45.65 <sup>2)</sup>	172.5 <sup>2)</sup>	4.58	3.41	57.95	43.21	86.06 <sup>2)</sup>		

- Not recommended to use as the internal leakage is over 50% of theoretical flow.  
 1) 050 = 210 bar (3000 psi) max. int 2) 028 - 031 = 210 bar (3000 psi) max.int

**VT67EB - 066 - B08 1 R 00 - A 1 M1 -**

**Series-** SAE C 2 bolts  
Mounting flange J744c

**Cam ring for "P1"**

Volumetric displacement cm<sup>3</sup>/rev (in<sup>3</sup>/rev)

042 = 132.3 (8.07)	062 = 196.7 (12.00)
045 = 142.4 (8.69)	066 = 213.3 (13.02)
050 = 158.5 (9.67)	072 = 227.1 (13.86)
052 = 164.8 (10.06)	085 = 269.8 (16.46)
057 = 180.7 (11.02)	

**Cam ring for "P2"**

Volumetric displacement cm<sup>3</sup>/rev (in<sup>3</sup>/rev)

B02 = 5.7 (0.35)	B09 = 28.0 (1.71)
B03 = 9.8 (0.60)	B10 = 31.8 (1.94)
B04 = 12.8 (0.78)	B11 = 34.9 (2.13)
B05 = 15.9 (0.97)	B12 = 40.9 (2.50)
B06 = 19.8 (1.21)	B14 = 45.1 (2.75)
B07 = 22.5 (1.37)	B15 = 50.0 (3.05)
B08 = 24.9 (1.52)	

**Type of shaft**

- 1 - keyed (SAE CC)
- 2 - keyed (no SAE)
- 3 - splined (SAE C)
- 4 - splined (SAE CC)

**Modifications**

**Mounting W/connection variables**

P1=1-1/2" P2=3/4" S=3-1/2"	
UNC	METRIC
01	M1

**Seal class**

- 1 - S1 (for mineral oil)
- 4 - S4 (for fire resistant fluids)
- 5 - S5 (for mineral oil and fire resistant fluids)

**Design letter**

**Porting combination (see page BM-1-5)**

00 - standard

**Direction of rotation (view on shaft end)**

- R - clockwise
- L - counter-clockwise

**INTERNAL LEAKAGE ( TYPICAL )**

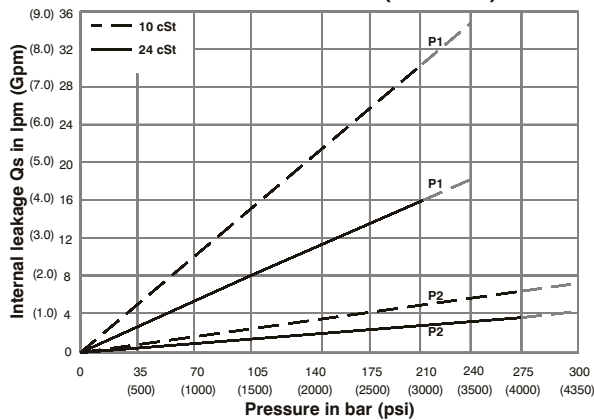

Do not operate pump more than 5 seconds at any speed or viscosity if internal leakage is more than 50% of theoretical flow.  
Total leakage is the sum of each section loss at its operating conditions.

**NOISE LEVEL ( TYPICAL )**

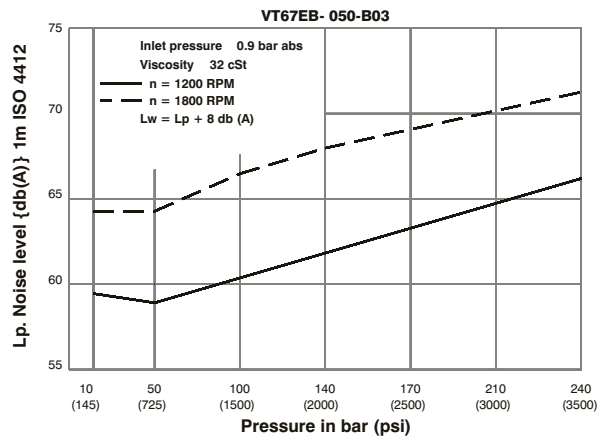

Double pump noise level is given with each section discharging at the pressure noted on the curve.

**HYDROMECHANICAL POWER LOSS ( TYPICAL )**

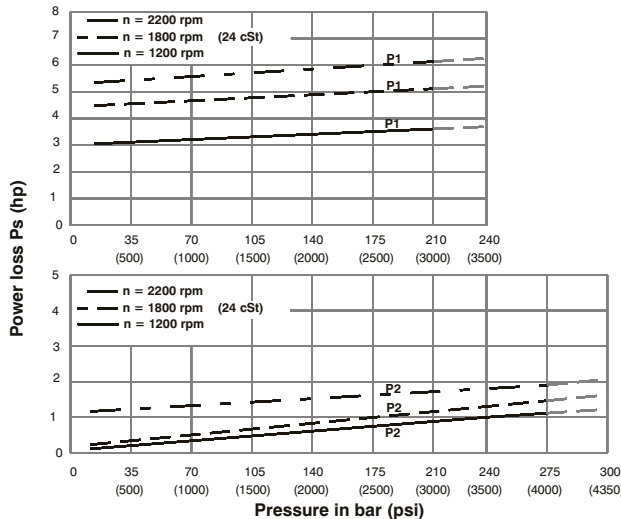

Total hydromechanical power loss is the sum of each section at its operating conditions.

**PERMISSIBLE RADIAL LOAD**

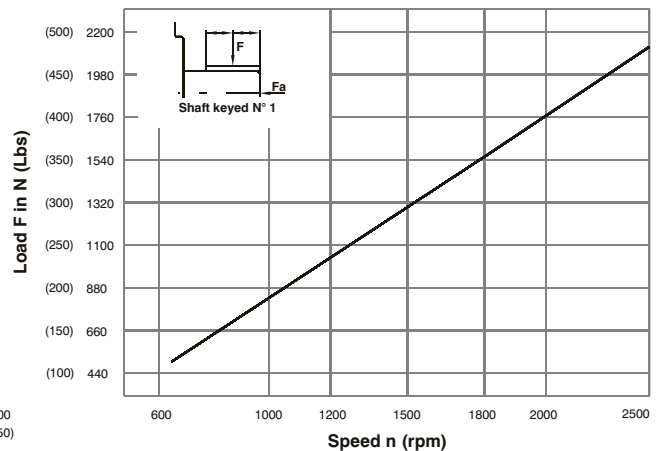

Maximum permissible axial load Fa = 2000 N (449 Lbs)



# HIGH PERFORMANCE VANE PUMP VT67EB

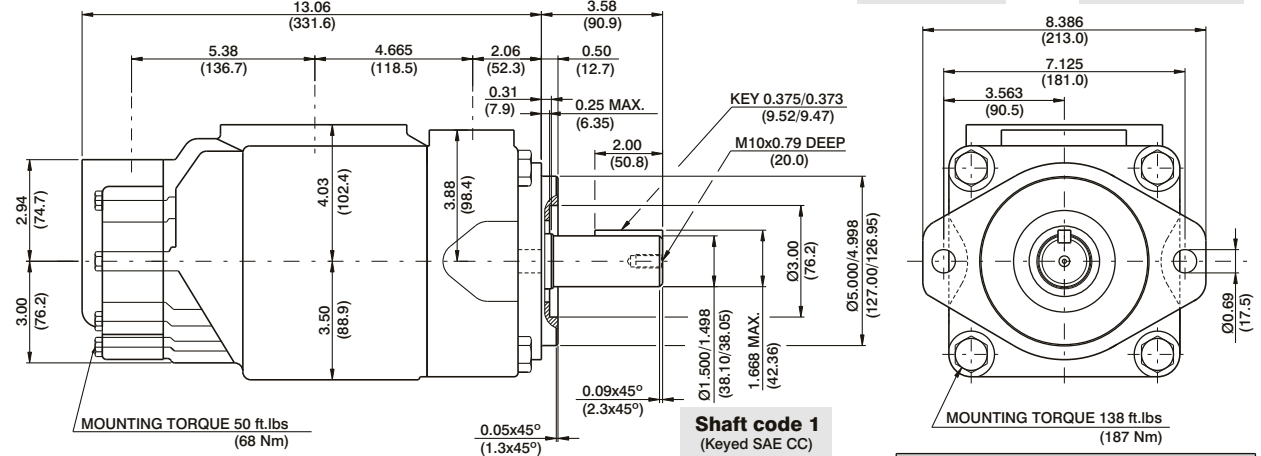
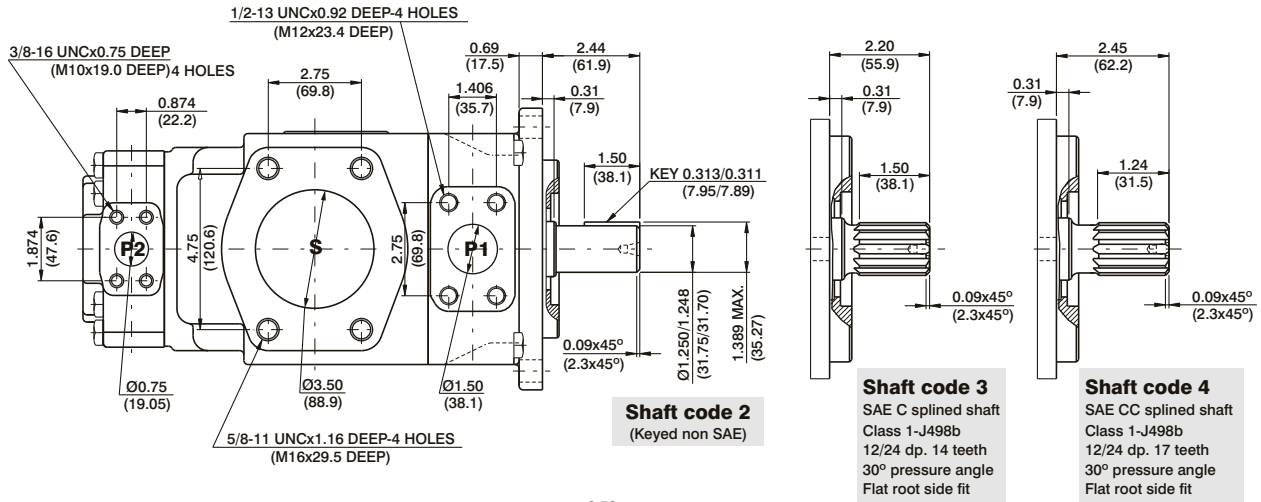

Shaft torque limits in <sup>3</sup> /rev x psi (ml/rev x bar)	
Shaft	Vp x p max. (P1+P2)
1	64044 (72306)
2	30638 (34590)
3	54207 (61200)
4	67582 (76376)

## OPERATING CHARACTERISTICS - TYPICAL (24 cST) (Input power p (KW) for one cartridge only)

Pressure port	Series	Volumetric Displacement Vp		Flow q & n = 1800 rpm						Input power p & n = 1800 rpm					
		p = 0 bar (0 psi)		p = 140 bar (2000 psi)		p = 240 bar (3500 psi)		p = 7 bar (100 psi)		p = 140 bar (2000 psi)		p = 240 bar (3500 psi)			
		in <sup>3</sup> /rev	cm <sup>3</sup> /rev	gpm	lpm	gpm	lpm	gpm	lpm	hp	kw	hp	kw	hp	kw
P1	042	8.07	132.3	62.92	237.8	60.37	228.2	58.52	221.2	8.09	6.03	78.44	58.49	133.80	99.78
	045	8.69	142.4	67.72	256.0	65.17	246.3	63.32	239.4	8.37	6.24	84.04	62.67	143.60	107.08
	050	9.67	158.5	75.38	285.0	72.83	275.3	70.98	268.3	8.82	6.58	92.97	69.30	159.24	118.7
	052	10.06	164.8	78.37	296.2	75.82	286.3	73.97	279.6	8.99	6.70	96.47	71.94	165.36	121.31
	057	11.02	180.7	71.70	325.3	69.07	261.1	80.63	304.8	9.40	7.00	114.30	85.14	172.10	128.30
	062	12.00	196.7	93.54	353.6	90.99	344.0	89.14	337.0	9.88	7.36	114.17	84.00	196.34	146.41
	066	13.02	213.3	101.44	383.4	98.89	373.8	97.04	366.8	10.34	7.71	123.38	92.01	212.46	158.43
	072	13.86	227.1	108.00	408.2	105.45	400.0	103.60	391.6	10.72	8.00	131.04	97.72	225.86	168.42
	085 <sup>1,2)</sup>	16.40	268.7	127.08	483.0	126.13	476.7	--	--	11.66	8.70	87.56	65.30	--	--
P2				p = 0 bar (0 psi)	p = 140 bar (2000 psi)	p = 300 bar (4350 psi)	p = 7 bar (100 psi)	p = 140 bar (2000 psi)	p = 300 bar (4350 psi)						
	B02	0.35	5.7	2.76	10.4	2.33	8.8	1.80	6.8	0.74	0.55	4.02	2.99	8.10	6.40
	B03	0.60	9.8	4.66	17.6	4.23	15.9	3.70	14.0	0.85	0.63	6.24	4.65	12.93	10.25
	B04	0.78	12.8	6.09	23.0	5.66	21.4	5.13	19.4	0.94	0.70	7.90	5.89	16.55	13.13
	B05	0.97	15.9	7.56	28.6	7.13	26.9	6.60	25.0	1.02	0.76	9.62	7.17	20.29	16.12
	B06	1.21	19.8	9.42	35.6	8.99	33.9	8.46	32.0	1.13	0.84	11.79	8.79	25.00	19.88
	B07	1.37	22.5	10.70	40.4	10.27	38.8	9.74	36.8	1.20	0.89	13.29	9.91	28.26	22.47
	B08	1.52	24.9	11.84	44.7	11.41	43.1	10.88	41.1	1.27	0.94	14.62	10.90	31.15	24.78
	B09	1.71	28.0	13.31	50.3	12.87	48.6	12.35	47.0	1.36	1.01	16.35	12.19	34.92	27.77
	B10	1.94	31.8	15.12	57.2	14.69	55.5	14.16	53.5	1.46	1.11	18.45	13.75	39.48	31.42
	B11 <sup>3)</sup>	2.13	34.9	16.64	62.9	16.19	61.2	15.68	59.3	1.55	1.15	20.17	15.04	43.22	32.22
	B12 <sup>3)</sup>	2.50	40.9	19.50	73.7	19.07	72.1	18.54	70.1	1.72	1.28	23.55	17.56	50.58	37.71
	B14 <sup>3)</sup>	2.75	45.1	21.40	80.8	20.95	79.2	20.44	77.0	1.83	1.36	25.80	19.23	55.48	41.37
	B15 <sup>3)</sup>	3.05	50.0	23.78	89.8	23.35	88.3	22.88	86.5	1.97	1.47	28.55	21.28	57.35	42.76

1) 085 = 2000 RPM max. 2) 085=75 bar (1087 psi)cont. 085=90 bar (1300 psi) max. int.  
3) B11-B12-B14 = 300 bar (4350 psi) & B15 = 280 bar (4060 psi) max. int. And Max. Speed = 3000 rpm

**VT67EC - 062 - 010 1 R 00 - A 1 00 - \***

**Series**-SAE C 2 bolts  
Mounting flange J744c

**Cam ring for "P1"**

Volumetric displacement  $\text{cm}^3 / \text{rev}$  ( $\text{in}^3 / \text{rev}$ )

042 = 132.2 (8.07)	057 = 183.2 (11.18)
045 = 142.5 (8.70)	062 = 196.6 (12.00)
050 = 158.5 (9.67)	066 = 213.0 (13.00)
052 = 163.8 (10.00)	072 = 227.1 (13.86)
054 = 170.9 (10.43)	085 = 268.7 (16.40)

**Cam ring for "P2"**

Volumetric displacement  $\text{cm}^3 / \text{rev}$  ( $\text{in}^3 / \text{rev}$ )

003 = 10.8 (0.66)	015 = 50.5 (3.08)
005 = 17.2 (1.05)	017 = 58.3 (3.56)
006 = 21.3 (1.30)	020 = 63.8 (3.89)
008 = 26.4 (1.61)	022 = 70.3 (4.29)
010 = 34.1 (2.08)	025 = 79.3 (4.84)
012 = 37.1 (2.26)	028 = 88.8 (5.42)
014 = 46.0 (2.81)	031 = 100.0 (6.10)

**Type of shaft**

- 1 - keyed (SAE CC)
- 2 - keyed (no SAE)
- 3 - splined (SAE C)
- 4 - splined (SAE CC)

**Modifications**

**Mounting W/connection variables**  
4 bolts SAE flange J518

TYPE	P1 = 1 1/2" & S = 3 1/2"			
	Metric thread		UNC thread	
CODE	M0	M1	00	01
P2	1"	3/4"	1"	3/4"

**Seal class**

- 1 - S1 (for mineral oil)
- 4 - S4 (for fire resistant fluids)
- 5 - S5 (for mineral oil and fire resistant fluids)

**Design letter**

**Porting combination (see page BM-1-5)**

00 - standard

**Direction of rotation (view on shaft end)**

- R - clockwise
- L - counter-clockwise

## INTERNAL LEAKAGE ( TYPICAL )

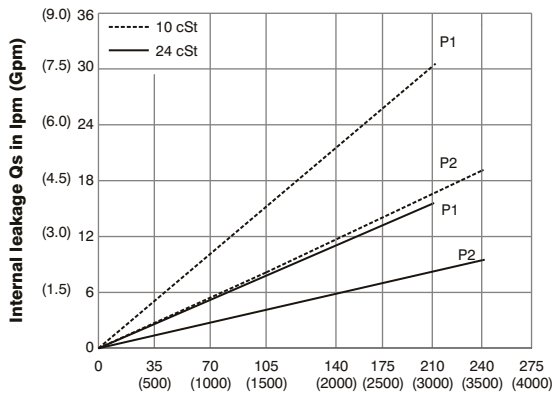

Do not operate pump more than 5 seconds at any speed or viscosity if internal leakage is more than 50% of theoretical flow.  
Total leakage is the sum of each section loss at its operating conditions.

## HYDROMECHANICAL POWER LOSS ( TYPICAL )

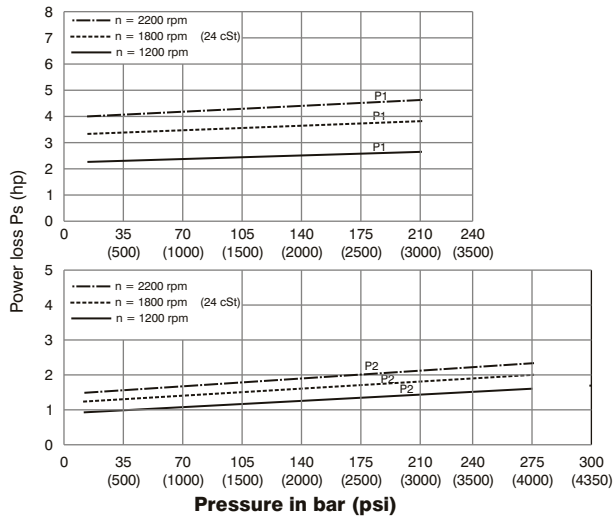

Total hydromechanical power loss is the sum of each section at its operating conditions.

## NOISE LEVEL ( TYPICAL ) VT67EC- 050-022

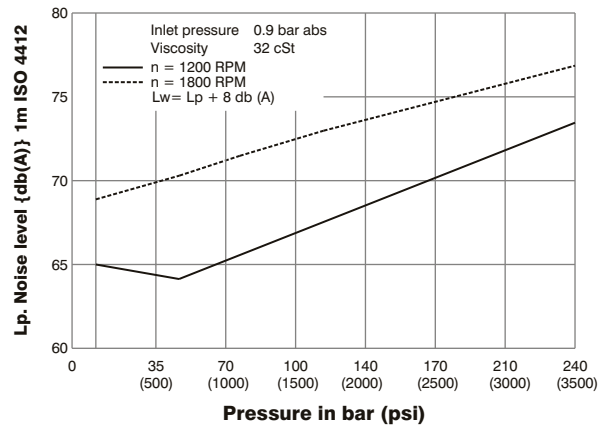

Double pump noise level is given with each section discharging at the pressure noted on the curve.

## PERMISSIBLE RADIAL LOAD

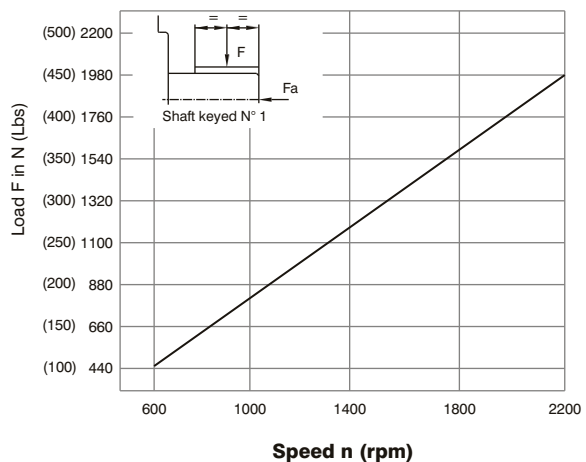

Maximum permissible axial load  $F_a = 2000$  N (449 Lbs)

# HIGH PERFORMANCE VANE PUMP VT67EC

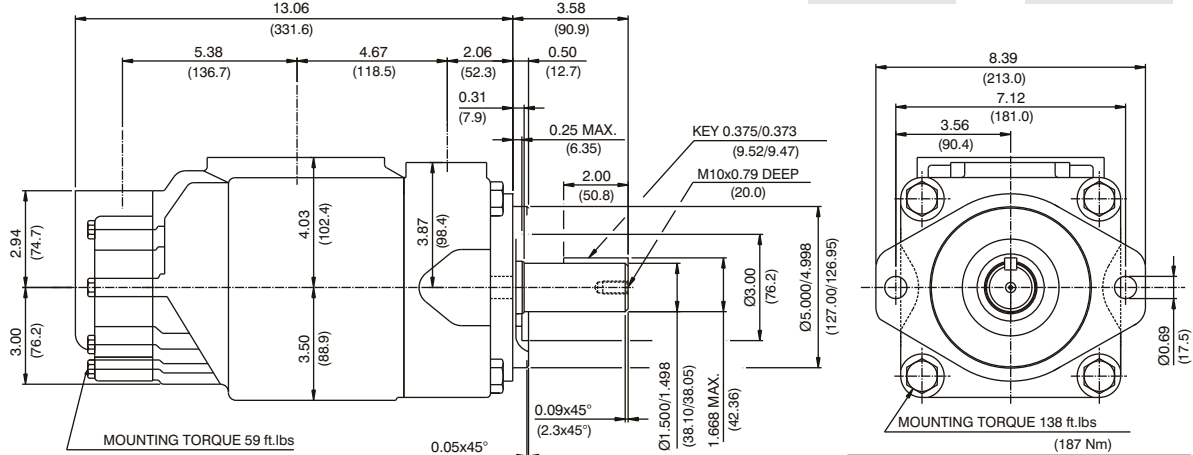
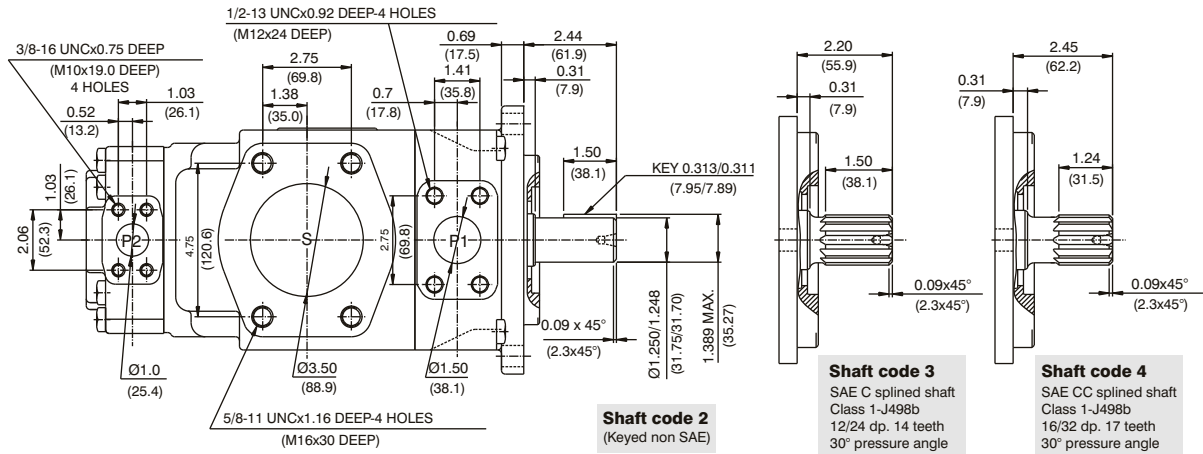

Shaft torque limits in <sup>3</sup> /rev x psi (ml/rev x bar)	
Shaft	Vp x p max. (P1+P2)
1	64039 (72306)
2	30638 (34590)
3	54207 (61200)
4	67582 (76376)

## OPERATING CHARACTERISTICS - TYPICAL (24 cST) (Input power p (KW) for one cartridge only)

Pressure port	Series	Volumetric Displacement Vp		Flow q & n = 1800 rpm						Input power p & n = 1800 rpm					
		in <sup>3</sup> /rev	cm <sup>3</sup> /rev	p = 0 bar (0 psi)		p = 140 bar (2000 psi)		p = 240 bar (3500 psi)		p = 7 bar (100 psi)		p = 140 bar (2000 psi)		p = 240 bar (3500 psi)	
				gpm	lpm	gpm	lpm	gpm	lpm	hp	kw	hp	kw	hp	kw
P1	042	8.07	132.2	62.92	237.8	60.37	228.2	58.52	221.2	8.09	6.03	78.44	58.49	133.80	99.77
	045	8.70	142.5	67.72	255.9	65.17	246.3	63.32	239.3	8.37	6.24	84.04	62.66	143.60	107.08
	050	9.67	158.5	75.38	284.9	72.83	275.3	70.98	268.3	8.82	6.58	92.97	69.32	159.24	118.75
	052	10.00	163.8	78.37	296.2	75.82	286.6	73.97	279.6	8.99	6.70	96.47	71.94	165.36	123.31
	054	10.43	170.9	81.27	307.2	78.72	297.6	76.87	290.6	9.17	6.84	99.75	74.38	177.46	132.33
	057	11.18	183.2	87.12	329.3	84.57	319.7	82.72	312.7	9.51	7.09	106.57	79.47	189.84	141.56
	062	12.00	196.6	93.54	353.6	90.99	343.9	89.14	336.9	9.88	7.37	114.17	85.13	196.34	146.41
	066	13.00	213.0	101.44	383.4	98.89	373.8	97.04	366.8	10.34	7.71	123.38	92.01	212.46	158.43
	072	13.86	227.1	108.00	408.2	105.45	398.6	103.60	391.6	10.72	7.99	131.04	97.71	225.86	166.42
085 <sup>1,2)</sup>	16.40	268.7	127.79	483.0	126.13	476.7	--	--	11.88	8.85	101.66	75.80	--	--	
P2	003	0.66	10.8	5.14	19.6	3.85	14.6	--	--	2.11	1.57	8.45	6.30	--	--
	005	1.05	17.2	8.18	30.9	6.89	26.0	5.68	21.5	2.29	1.70	12.00	8.94	19.81	14.77
	006	1.30	21.3	10.13	38.3	8.84	33.4	7.63	28.8	2.40	1.78	14.28	10.64	23.79	17.74
	008	1.61	26.4	12.55	47.4	11.26	42.6	10.05	37.9	2.54	1.89	17.11	12.75	28.75	21.43
	010	2.08	34.1	16.22	61.3	14.93	56.4	13.71	51.8	2.76	2.06	21.38	15.94	36.22	27.00
	012	2.26	37.1	17.64	66.7	16.35	61.8	15.14	57.2	2.84	2.11	23.05	17.18	39.14	29.18
	014	2.81	46.0	21.88	82.7	20.59	77.8	19.37	73.2	3.09	2.30	27.99	20.87	47.78	35.62
	015	3.08	50.5	23.99	90.7	22.83	86.3	21.56	81.5	3.21	2.40	30.30	22.60	51.36	38.30
	017	3.56	58.3	27.73	104.8	26.44	99.9	25.22	95.3	3.43	2.55	34.81	25.95	59.73	44.54
	020	3.89	63.8	30.34	114.7	29.05	109.8	27.84	105.2	3.58	2.66	37.86	28.23	65.07	48.52
	022 <sup>4)</sup>	4.29	70.3	33.43	126.4	32.14	121.5	30.93	116.9	3.76	2.80	41.47	30.92	71.38	53.22
	025 <sup>3,5)</sup>	4.84	79.3	37.71	142.5	36.42	137.6	35.21	133.1	4.01	2.99	46.46	34.64	80.12	59.74
	028 <sup>3,6)</sup>	5.42	88.8	42.23	159.6	40.94	154.7	40.32	152.4	4.27	3.18	51.74	38.58	76.73	57.22
	031 <sup>3,6)</sup>	6.10	100.0	47.56	179.7	46.27	174.9	45.65	172.5	4.58	3.41	57.95	43.21	86.06	64.17

1) 085 = 90 bar (1300 psi) max. int. 2) 085 = 2000 RPM max. 3) 025-028-031 = 2500 R.P.M. max. 4) 022 = 275 bar max. int.  
 5) 025 = 240 bar max. int. 6) 028-031 = 210 bar max. int. -- Not recommended to use as the internal leakage is over 50 of theoretical flow.