

3MICT

vt6cr	2
vt6crm	4
vt6dccb	6
vt6dr	9
vt6drm	11
vt6edcr	13
vt6ees	16
vt6er	18
vt6erm	20
vt7ees	22

VT6CR * - 022 - 1 R 00 - A 1 0 - A 1 *

Series

Y - Metric port connection, Omit for UNC

Cam ring for

Volumetric displacement cm^3/rev (in^3/rev)

*003/B03/Y03 = 10.8 (0.66)	015/B15/Y15 = 50.5 (3.08)
005/B05/Y05 = 17.2 (1.05)	017/B17/Y17 = 58.3 (3.56)
006/B06/Y06 = 21.3 (1.30)	020/B20/Y20 = 63.8 (3.89)
008/B08/Y08 = 26.4 (1.61)	022/B22/Y22 = 70.3 (4.29)
010/B10/Y10 = 34.1 (2.08)	025/B25/Y25 = 79.3 (4.84)
012/B12/Y12 = 37.1 (2.26)	028/B28/Y28 = 88.8 (5.42)
014/B14/Y14 = 46.0 (2.81)	031/B31/Y31 = 100.0 (6.10)

*'0' - Uni - directional 'B' - Bi - directional 'Y' - Bi - directional for cold start

Type of Shaft

- 1 - Keyed (SAE BB)
- 2 - Keyed (no SAE)
- 3 - Splined (SAE B)
- 4 - Splined (SAE BB)
- 5 - Keyed (no SAE)

Direction of rotation (view on shaft end)

- R - Clockwise
- L - Counter - clockwise

Porting combination

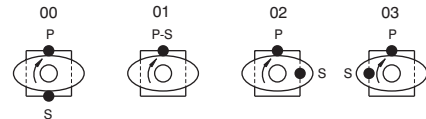

Modifications

Seal class

- 1 - S1 (for mineral oil)
- 4 - S4 (for fire resistant fluids)
- 5 - S5 (for mineral oil and fire resistant fluids)

Design letter

Porting adapter

Coupling

- 1 - SAE A
- 2 - SAE B
- 3 - SAE BB
- 4 - SAE C
- 5 - SAE J498b
- 16/32-11 teeth

Adapter

- 0 - None
- A - SAE A
- B - SAE B
- C - SAE C

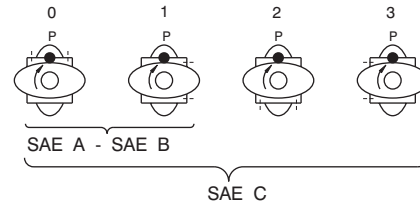

INTERNAL LEAKAGE (TYPICAL)

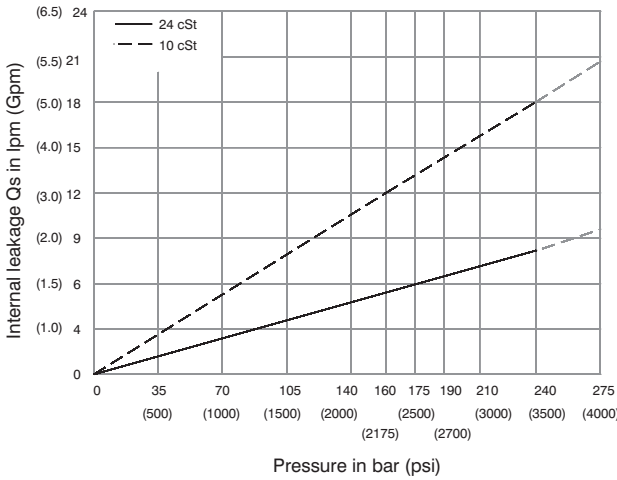

Do not operate pump more than 5 seconds at any speed or viscosity if internal leakage is more than 50% of theoretical flow.

NOISE LEVEL (TYPICAL)

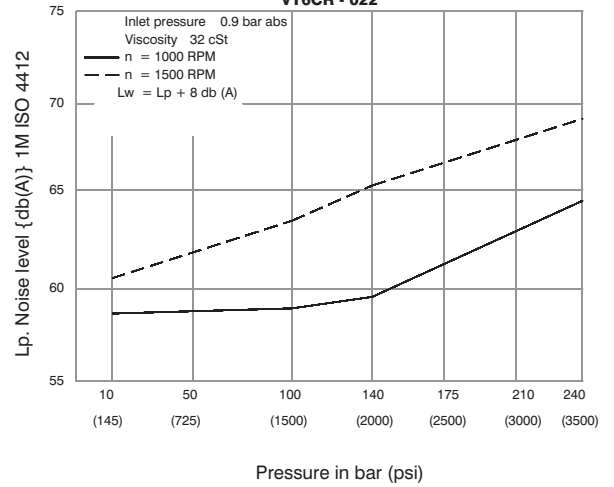

HYDROMECHANICAL POWER LOSS (TYPICAL)

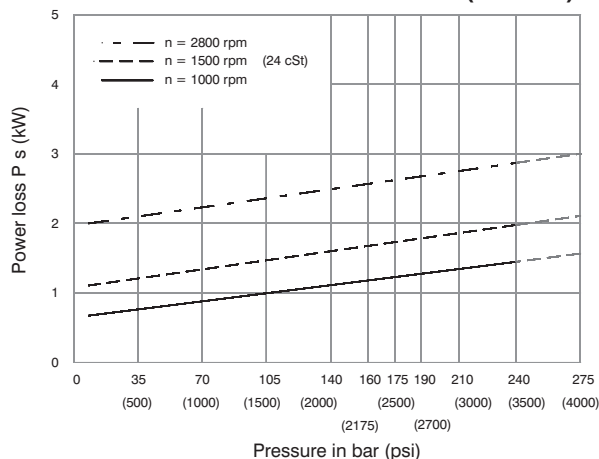

PERMISSIBLE RADIAL LOAD

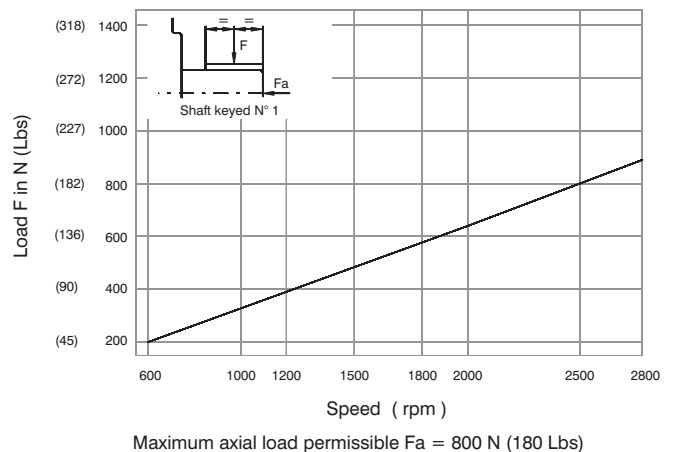

Maximum axial load permissible $F_a = 800 \text{ N}$ (180 Lbs)



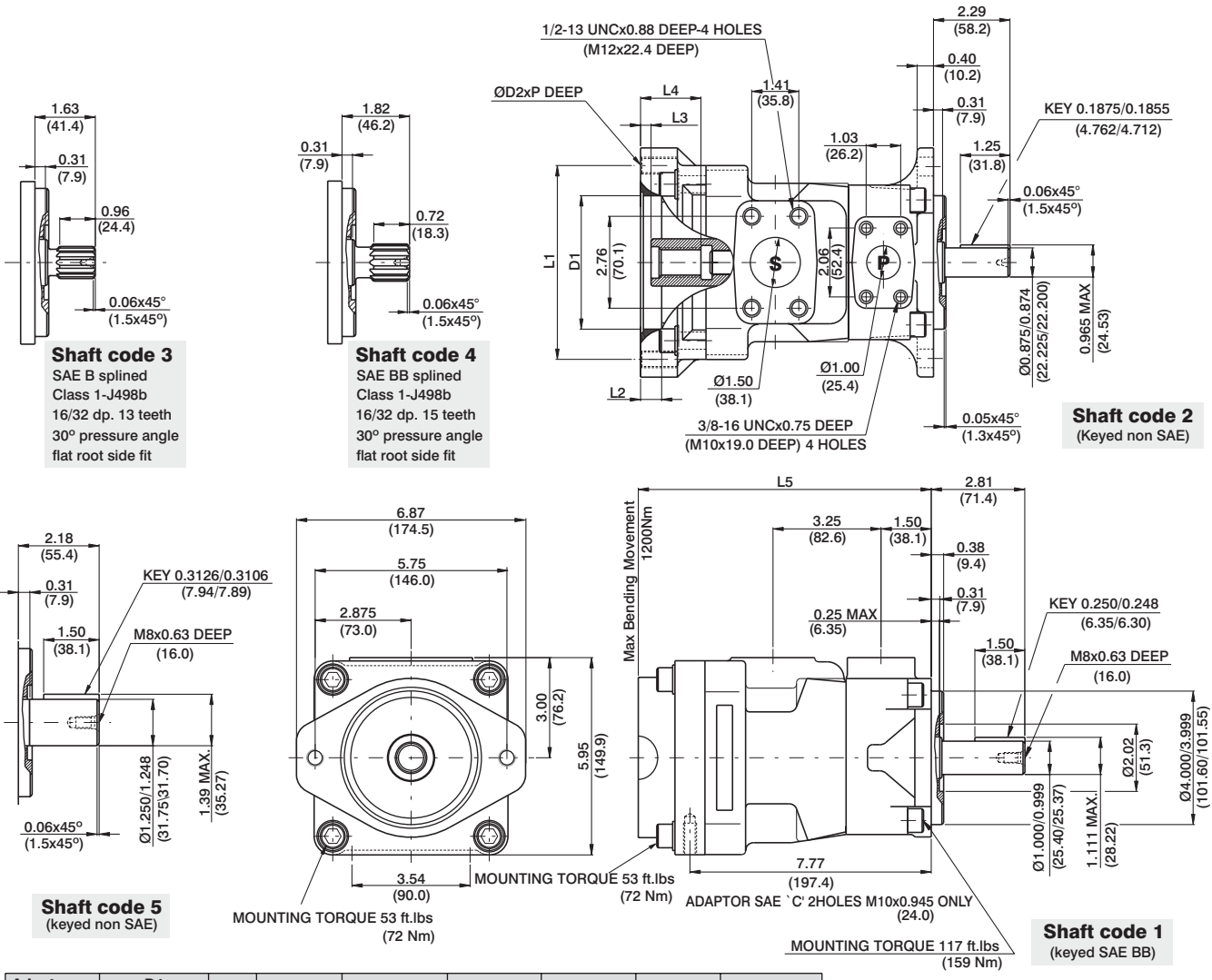

Adaptor	D1	D2	P	L1	L2	L3	L4	L5
SAE "A"	3.25 (82.60)	M10	0.94 (24)	4.19 (106.4)	0.43 (11)	0.31 (7.9)	1.26 (32)	8.23 (209)
SAE "B"	4.00 (101.65)	M12	1.10 (28)	5.75 (146.0)	0.63 (16)	0.31 (7.9)	1.81 (46)	8.78 (223)
SAE "C"	5.00 (127.10)	M16	-	7.12 (181.0)	0.63 (16)	0.31 (7.9)	2.20 (56)	9.17 (233)

Adaptor	SAE "A"			SAE "B"		SAE "C"
Coupling drive	SAE A	SAE (11teeth)	SAE B	SAE B	SAE BB	SAE C
Number of teeth	9	11	13	13	15	14
Pitch	16/32	16/32	16/32	16/32	16/32	12/24
Pressure angle	30°	30°	30°	30°	30°	30°
Major dia. (min)	0.625 (15.875)	0.750 (19.05)	0.875 (22.225)	0.875 (22.225)	1.00 (25.40)	1.250 (31.75)
Minor dia. (min)	0.500 (12.70)	0.630 (16.00)	0.753 (19.125)	0.753 (19.125)	0.877 (22.275)	1.086 (27.585)

Shaft torque limits in ³ /rev x psi (ml/rev x bar)			
Shaft	V x P max.	Coupling drive	V x P max.
1	18972 (21420)	SAE"A"	9743 (11000)
2	12666 (14300)	SAE"B"	18246 (20600)
3	18246 (20600)	SAE"BB"	19530 (22050)
4	28937 (32670)	SAE"C"	19530 (22050)
5	30274 (34180)	SAE"11teeth"	14039 (15850)

OPERATING CHARACTERISTICS - TYPICAL (24 cST)

Pressure port	Series	Volumetric Displacement Vp		Flow q & n = 1500 rpm						Input power p & n = 1500 rpm					
		p = 0 bar (0 psi)		p = 140 bar (2000 psi)		p = 240 bar (3500 psi)		p = 7 bar (100 psi)		p = 140 bar (2000 psi)		p = 240 bar (3500 psi)			
		in ³ /rev	cm ³ /rev	gpm	lpm	gpm	lpm	gpm	lpm	hp	kw	hp	kw	hp	kw
VT6CR	003	0.66	10.8	4.29	16.2	2.96	11.2	2.04	7.7	1.74	1.3	7.11	5.3	11.26	8.4
	005	1.05	17.2	6.83	25.8	5.50	20.8	4.57	17.3	1.88	1.4	10.06	7.5	16.36	12.2
	006	1.30	21.3	8.44	31.9	7.11	26.9	6.19	23.4	2.01	1.5	11.94	8.9	19.71	14.7
	008	1.61	26.4	10.48	39.6	9.15	34.6	8.22	31.1	2.15	1.6	14.35	10.7	22.93	17.7
	010	2.08	34.1	13.52	51.1	12.19	46.1	11.26	42.6	2.28	1.7	18.64	13.4	29.90	22.3
	012	2.26	37.1	14.71	55.6	13.36	50.6	12.46	47.1	2.28	1.7	19.31	14.4	32.32	24.1
	014	2.81	46.0	18.25	69.0	16.93	64.0	16.00	60.5	2.55	1.9	23.60	17.6	39.56	29.5
	015	3.08	50.5	20.00	75.6	18.73	73.2	19.02	67.5	2.68	2.0	25.61	19.1	42.91	32.0
	017	3.56	58.3	23.12	87.4	21.79	82.4	20.87	78.9	2.82	2.1	29.37	21.9	49.48	36.9
	020	3.89	63.8	25.32	95.7	23.99	90.7	23.07	87.2	2.95	2.2	31.92	23.8	53.91	40.2
	022	4.29	70.3	27.88	105.4	26.56	100.4	25.63	96.9	3.08	2.3	35.00	26.1	59.14	44.1
	025 ¹⁾	4.84	79.3	31.46	118.9	30.13	113.9	29.21	110.4	3.35	2.5	39.16	29.2	66.38	49.5
	028 ¹⁾	5.42	88.8	35.24	133.2	33.92	128.2	33.28 ²⁾	125.8 ²⁾	3.75	2.8	43.85	32.7	65.04 ²⁾	48.5 ²⁾
031 ¹⁾	6.10	100.0	39.68	150.0	38.35	145.0	37.72 ²⁾	142.6 ²⁾	3.75	2.8	48.95	36.5	72.95 ²⁾	54.4 ²⁾	

1) 025-028-031 = 2500 RPM. max.

2) 028-031 = 210 bar (3000 psi) max. int.

VT6CRM * - B22 - 1 R 00 - A 1 0 - A 1 *

Series

Y- Metric port connection, Omit for UNC

Cam ring for

Volumetric displacement cm³/rev (in³/rev)

*B03/R03 = 10.8 (0.66)	B15/R15 = 50.5 (3.08)
B05/R05 = 17.2 (1.05)	B17/R17 = 58.3 (3.56)
B06/R06 = 21.3 (1.30)	B20/R20 = 63.8 (3.89)
B08/R08 = 26.4 (1.61)	B22/R22 = 70.3 (4.29)
B10/R10 = 34.1 (2.08)	B25/R25 = 79.3 (4.84)
B12/R12 = 37.1 (2.26)	B28/R28 = 88.8 (5.42)
B14/R14 = 46.0 (2.81)	B31/R31 = 100.0 (6.10)

*'B' - for Mobile
*'R' - for Mobile - spring assisted

Type of Shaft

- 1 - Keyed (SAE BB)
- 2 - Keyed (no SAE)
- 3 - Splined (SAE B)
- 4 - Splined (SAE BB)
- 5 - Keyed (no SAE)

Direction of rotation (view on shaft end)

- R - Clockwise
- L - Counter - clockwise

Porting combination

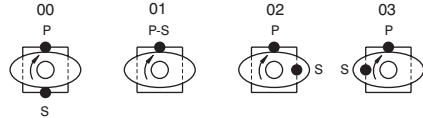

Modifications

- Seal class**
- 1 - S1 (for mineral oil)
 - 4 - S4 (for fire resistant fluids)
 - 5 - S5 (for mineral oil and fire resistant fluids)

Design letter

Porting adapter

Coupling

- 1 - SAE A
- 2 - SAE B
- 3 - SAE BB
- 4 - SAE C
- 5 - SAE J498b
16/32-11 teeth

Adapter

- 0 - None
- A - SAE A
- B - SAE B
- C - SAE C

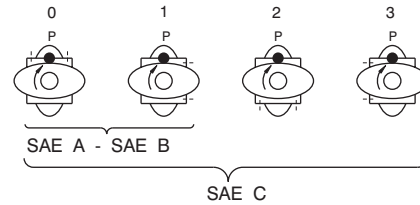

INTERNAL LEAKAGE (TYPICAL)

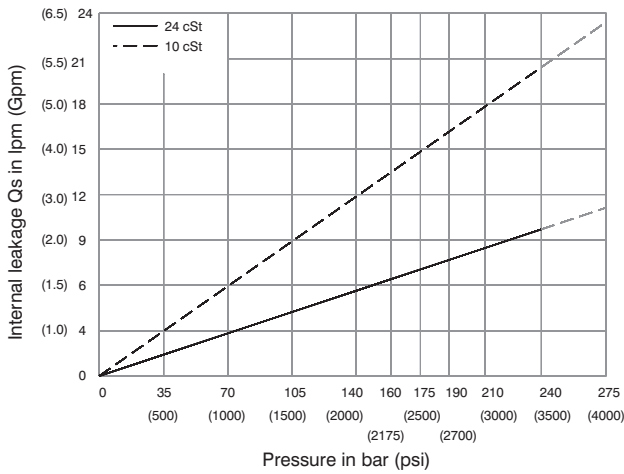

Do not operate pump more than 5 seconds at any speed or viscosity if internal leakage is more than 50% of theoretical flow.

NOISE LEVEL (TYPICAL)

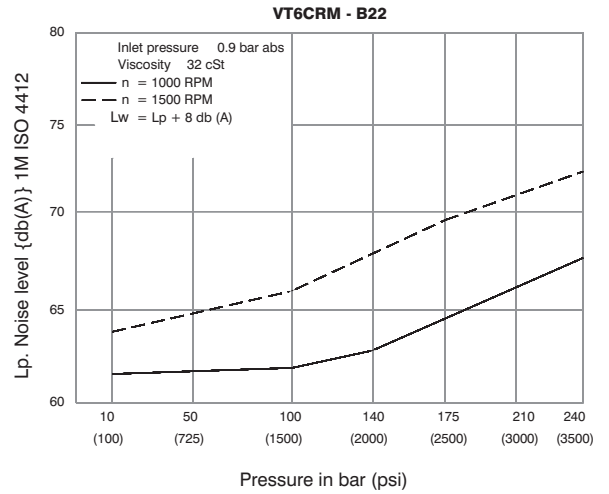

HYDROMECHANICAL POWER LOSS (TYPICAL)

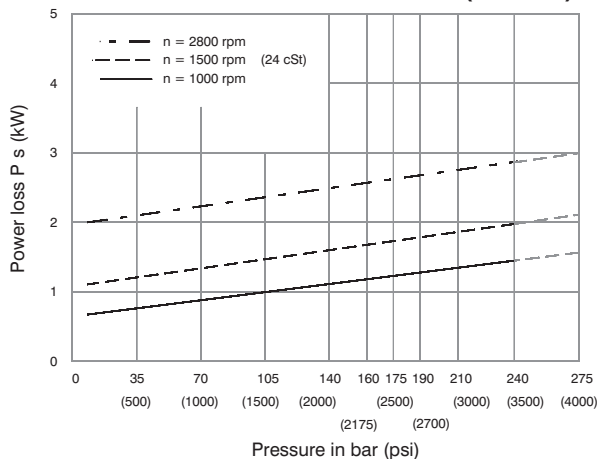

PERMISSIBLE RADIAL LOAD

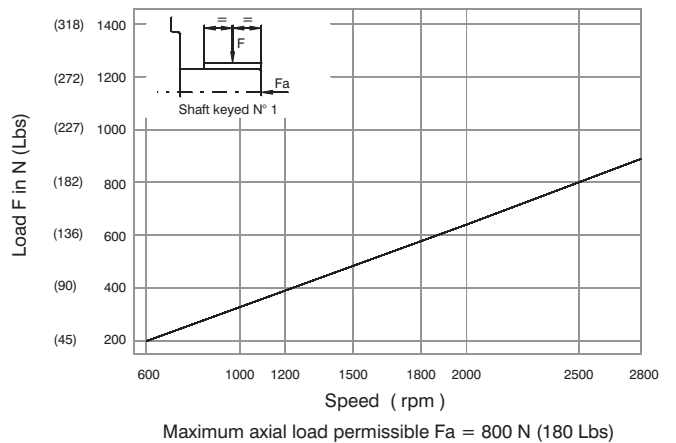

Maximum axial load permissible Fa = 800 N (180 Lbs)



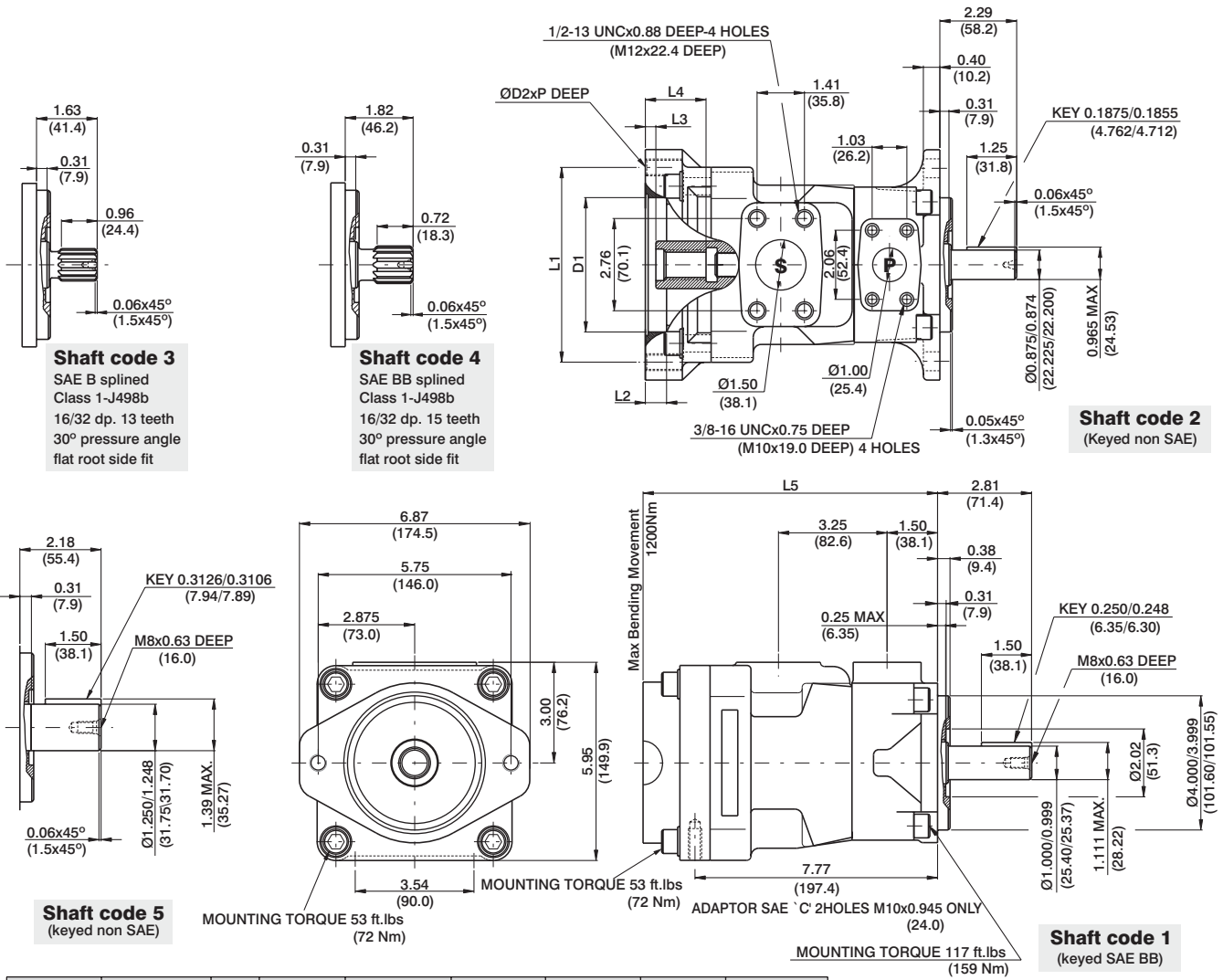

Adaptor	D1	D2	P	L1	L2	L3	L4	L5
SAE "A"	3.25 (82.6)	M10	0.94 (24)	4.19 (106.4)	0.43 (11)	0.31 (7.9)	1.26 (32)	8.23 (209)
SAE "B"	4.00 (101.65)	M12	1.10 (28)	5.75 (146.0)	0.63 (16)	0.31 (7.9)	1.81 (46)	8.78 (223)
SAE "C"	5.00 (127.10)	M16	-	7.12 (181.0)	0.63 (16)	0.31 (7.9)	2.20 (56)	9.17 (233)

Adaptor	SAE "A"			SAE "B"		SAE "C"
Coupling drive	SAE A	SAE (11teeth)	SAE B	SAE B	SAE BB	SAE C
Number of teeth	9	11	13	13	15	14
Pitch	16/32	16/32	16/32	16/32	16/32	12/24
Pressure angle	30°	30°	30°	30°	30°	30°
Major dia. (min)	0.625 (15.875)	0.750 (19.05)	0.875 (22.225)	0.875 (22.225)	1.00 (25.40)	1.250 (31.75)
Minor dia. (min)	0.500 (12.70)	0.630 (16.00)	0.753 (19.125)	0.753 (19.125)	0.877 (22.275)	1.086 (27.585)

Shaft	Shaft torque limits in ³ /rev x psi (ml/rev x bar)	
	V x P max.	Coupling drive V x P max.
1	18972 (21420)	SAE"A" 9743 (11000)
2	12666 (14300)	SAE"B" 18246 (20600)
3	18246 (20600)	SAE"BB" 19530 (22050)
4	28937 (32670)	SAE"C" 19530 (22050)
5	30274 (34180)	SAE"11teeth" 14039 (15850)

OPERATING CHARACTERISTICS - TYPICAL (24 cST)

Pressure port	Series	Volumetric Displacement Vp		Flow q & n = 1500 rpm						Input power p & n = 1500 rpm					
		p = 0 bar (0 psi)		p = 140 bar (2000 psi)		p = 240 bar (3500 psi)		p = 7 bar (100 psi)		p = 140 bar (2000 psi)		p = 240 bar (3500 psi)			
		in ³ /rev	cm ³ /rev	gpm	lpm	gpm	lpm	gpm	lpm	hp	kw	hp	kw		
VT6CRM	B03	0.66	10.8	4.29	16.2	2.83	11.2	7.7	7.7	1.74	1.3	7.11	5.3	8.4	8.4
	B05	1.05	17.2	6.83	25.8	5.37	20.8	4.17	17.3	1.88	1.4	10.06	7.5	16.36	12.2
	B06	1.30	21.3	8.44	31.9	7.01	26.9	5.82	23.4	2.01	1.5	11.94	8.9	19.71	14.7
	B08	1.61	26.4	10.48	39.6	9.02	34.6	7.83	31.1	2.15	1.6	14.35	10.7	22.93	17.7
	B10	2.08	34.1	13.52	51.1	12.08	46.1	10.89	42.6	2.28	1.7	18.64	13.4	29.90	22.3
	B12	2.26	37.1	14.71	55.6	13.28	50.6	12.08	47.1	2.28	1.7	19.31	14.4	32.32	24.1
	B14	2.81	46.0	18.25	69.0	16.79	64.0	15.60	60.5	2.55	1.9	23.60	17.6	39.56	29.5
	B15	3.08	50.5	20.00	75.6	18.62	70.4	17.46	66.0	2.68	2.0	25.61	19.1	42.91	32.0
	B17	3.56	58.3	23.12	87.4	21.69	82.4	20.50	78.9	2.82	2.1	29.37	21.9	49.48	36.9
	B20	3.89	63.8	25.32	95.7	23.86	90.7	22.67	87.2	2.95	2.2	31.92	23.8	53.91	40.2
	B22	4.29	70.3	27.88	105.4	26.45	100.4	25.26	96.9	3.08	2.3	35.00	26.1	59.14	44.1
	B25 ⁽¹⁾	4.84	79.3	31.46	118.9	30.02	113.9	28.83	110.4	3.35	2.5	39.16	29.2	66.38	49.5
	B28 ⁽¹⁾	5.42	88.8	35.24	133.2	33.78	128.2	32.93 ⁽²⁾	125.8 ⁽²⁾	3.75	2.8	43.85	32.7	72.95 ⁽²⁾	54.4 ⁽²⁾
B31 ⁽¹⁾	6.10	100.0	39.68	150.0	38.22	145.0	37.38 ⁽²⁾	142.6 ⁽²⁾	3.75	2.8	48.95	36.5	72.95 ⁽²⁾	54.4 ⁽²⁾	

1) B25-B28-B31 = 2500 R.P.M. max.

2) B28-B31 = 210 bar (3000 psi) max. int.

-- Not to use because internal leakage greater than 50% theoretical flow

VT6DCCR - 038 - 028 - 008 - 2 R 00 - A 1 - 00 - *

Series

Rear cap end for mounting
SAE "A" auxiliary pump
coupling adaptor
SAE "A" -9 teeth

Cam ring for "P1"

Volumetric displacement cm³/rev (in³/rev)

*014/B14 = 47.6 (2.90)	035/B35 = 111.0 (6.77)
017/B17 = 58.2 (3.55)	038/B38 = 120.3 (7.34)
020/B20 = 66.0 (4.03)	042/B42 = 136.0 (8.30)
024/B24 = 79.5 (4.85)	045/B45 = 145.7 (8.89)
028/B28 = 89.7 (5.47)	050/B50 = 158.0 (9.64)
031/B31 = 98.3 (6.00)	061/B61 = 190.5 (11.62)

*'0' - Uni - directional 'B' - Bi - directional

Cam ring for "P2" & "P3"

Volumetric displacement cm³/rev (in³/rev)

*003/B03 = 10.8 (0.66)	015/B15 = 50.5 (3.08)
005/B05 = 17.2 (1.05)	017/B17 = 58.3 (3.56)
006/B06 = 21.3 (1.30)	020/B20 = 63.8 (3.89)
008/B08 = 26.4 (1.61)	022/B22 = 70.3 (4.29)
010/B10 = 34.1 (2.08)	025/B25 = 79.3 (4.84)
012/B12 = 37.1 (2.26)	028/B28 = 88.8 (5.42)
014/B14 = 46.0 (2.81)	031/B31 = 100.0 (6.10)

*'0' - Uni - directional 'B' - Bi - directional

Modifications

Mounting w/connection variables

	UNC		METRIC	
	00	01	M0	M1
P3	1"	3/4"	1"	3/4"

Seal class

- 1 - S1 (for mineral oil)
- 4 - S4 (for fire resistant fluids)
- 5 - S5 (for mineral oil and fire resistant fluids)

Design letter

Porting combination (see page DI-1-13)

00 = Standard

Direction of rotation (view on shaft end)

- R - Clockwise
- L - Counter - clockwise

Type of Shaft

- 2 - Keyed (SAE CC)
- 3 - Splined (SAE D & E)



OPERATING CHARACTERISTICS - TYPICAL (24 cST) (Input power p (KW) for one cartridge only)

Pressure port	Series	Volumetric Displacement Vp		Flow q & n = 1500 rpm						Input power p & n = 1500 rpm					
				p = 0 bar (0 psi)		p = 140 bar (2000 psi)		p = 240 bar (3500 psi)		p = 7 bar (100 psi)		p = 140 bar (2000 psi)		p = 240 bar (3500 psi)	
				in ³ /rev	cm ³ /rev	gpm	lpm	gpm	lpm	gpm	lpm	hp	kw	hp	kw
P1	014	2.90	47.6	18.88	71.4	16.42	62.1	14.78	55.9	3.08	2.3	24.81	18.5	41.03	30.6
	017	3.55	58.2	23.09	87.3	20.63	78.0	18.99	71.8	3.35	2.5	29.75	22.2	49.60	37.0
	020	4.00	66.0	26.19	99.0	23.73	89.7	22.08	83.5	3.75	2.8	33.39	24.9	55.92	41.7
	024	4.80	79.5	31.56	119.3	29.10	110.0	27.46	103.8	4.02	3.0	39.69	29.6	66.78	49.8
	028	5.50	89.7	35.58	134.5	33.12	125.2	31.48	119.0	4.29	3.2	44.52	33.2	74.96	55.9
	031	6.00	98.3	39.00	147.5	36.53	138.1	34.89	131.9	4.42	3.3	48.54	36.2	81.80	61.0
	035	6.80	111.0	44.04	166.5	41.58	157.2	39.94	151.0	4.69	3.5	54.58	40.7	92.13	68.7
	038	7.30	120.3	47.72	180.4	45.26	171.1	43.62	164.9	4.96	3.7	58.87	43.9	99.64	74.3
	042 ¹⁾	8.30	136.0	53.96	204.0	51.50	194.7	49.86	188.5	5.36	4.0	66.25	49.4	112.24	83.7
	045 ¹⁾	8.89	145.7	57.80	218.5	55.34	209.2	53.70	203.0	5.50	4.1	70.81	52.8	120.02	89.5
	050 ¹⁾	9.64	158.0	62.69	237.0	60.23	227.7	59.25 ²⁾	224.0 ²⁾	5.90	4.4	76.44	57.0	113.98 ²⁾	85.0 ²⁾
061 ¹⁾	11.62	190.5	76.25	285.7	73.54 ³⁾	278.0 ³⁾	--	--	6.16	4.6	81.26 ³⁾	60.6 ³⁾	--	--	
P2 & P3	003	0.66	10.8	4.29	16.2	2.96	11.2	2.04	7.7	1.74	1.3	7.11	5.3	11.22	8.4
	005	1.05	17.2	6.83	25.8	5.50	20.8	4.57	17.3	1.88	1.4	10.06	7.5	16.36	12.2
	006	1.30	21.3	8.44	31.9	7.11	26.9	6.19	23.4	2.01	1.5	11.94	8.9	19.71	14.7
	008	1.61	26.4	10.48	39.6	9.15	34.6	8.22	31.1	2.15	1.6	14.35	10.7	22.93	17.7
	010	2.08	34.1	13.52	51.1	12.19	46.1	11.26	42.6	2.28	1.7	18.64	13.4	29.90	22.3
	012	2.26	37.1	14.71	55.6	13.36	50.6	12.46	47.1	2.28	1.7	19.31	14.4	32.32	24.1
	014	2.81	46.0	18.25	69.0	16.93	64.0	16.00	60.5	2.55	1.9	23.60	17.6	39.56	29.5
	015	3.08	50.5	20.00	75.6	18.73	73.2	19.02	67.5	2.68	2.0	25.61	19.1	42.91	32.0
	017	3.56	58.3	23.12	87.4	21.79	82.4	20.87	78.9	2.82	2.1	29.37	21.9	49.48	36.9
	020	3.89	63.8	25.32	95.7	23.99	90.7	23.07	87.2	2.95	2.2	31.92	23.8	53.91	40.2
	022	4.29	70.3	27.88	105.4	26.56	100.4	25.63	96.9	3.08	2.3	35.00	26.1	59.14	44.1
025	4.84	79.3	31.46	118.9	30.13	113.9	29.21	110.4	3.35	2.5	39.16	29.2	66.38	49.5	
028	5.42	88.8	35.24	133.2	33.92	128.2	33.28 ²⁾	125.8 ²⁾	3.75	2.8	43.85	32.7	65.04 ²⁾	48.5 ²⁾	
031	6.10	100.0	39.68	150.0	38.35	145.0	37.72 ²⁾	142.6 ²⁾	3.75	2.8	48.95	36.5	72.95 ²⁾	54.4 ²⁾	

1) 042-045-050-061=2200 RPM max.

2) 028-031- 050=210 bar (3000 psi) max.

3) 061 = 120 bar (1740 psi) max. int, 061 = 80 bar (1160 psi) cont.

INTERNAL LEAKAGE (TYPICAL)

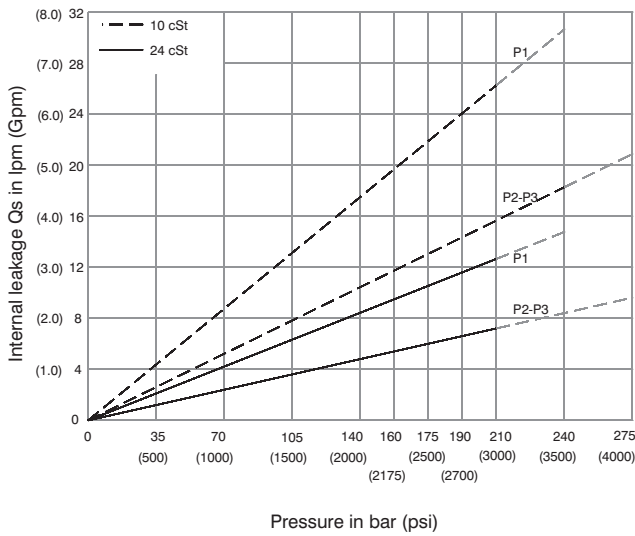

Total leakage is the sum of each section loss at its operating conditions.

NOISE LEVEL (TYPICAL)

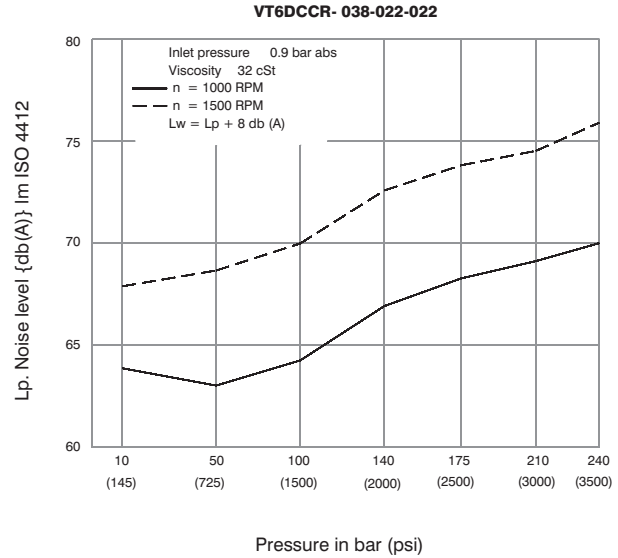

Triple pump noise level is given with each section discharging at the pressure noted on the curve.



HYDROMECAHNICAL POWER LOSS (TYPICAL)

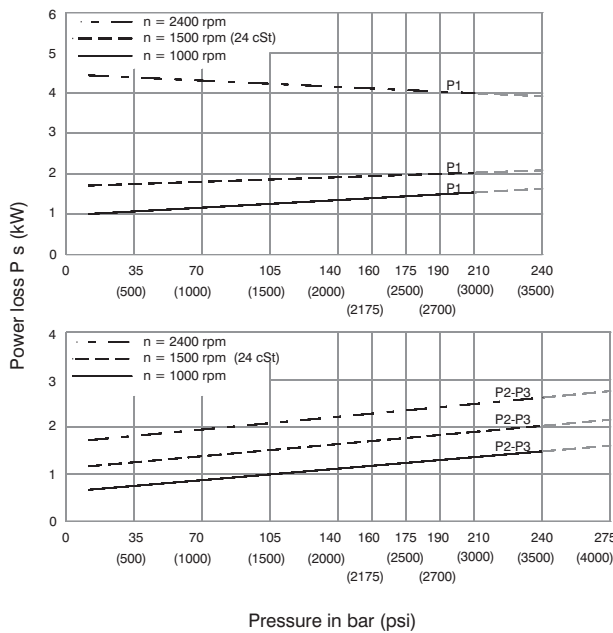

Total hydromechanical power loss is the sum of each section at its operating conditions.

PERMISSIBLE RADIAL LOAD

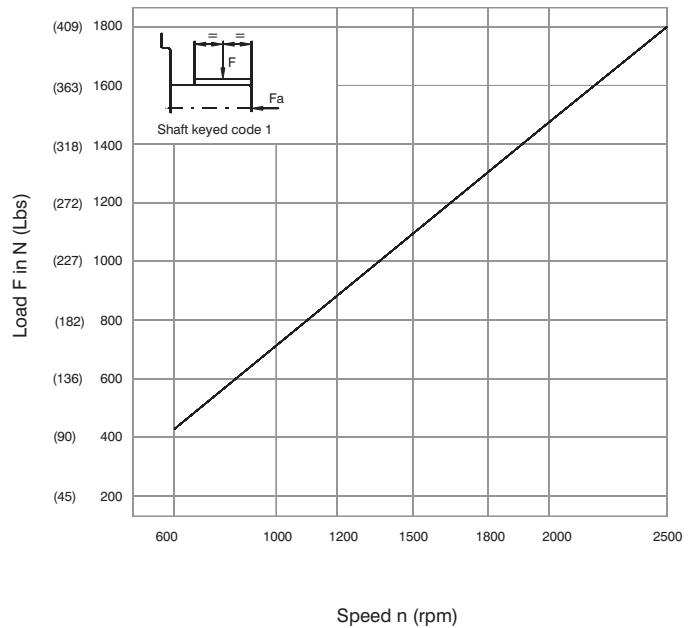

Maximum axial load permissible $F_a = 1200$ N (449 Lbs)

DT

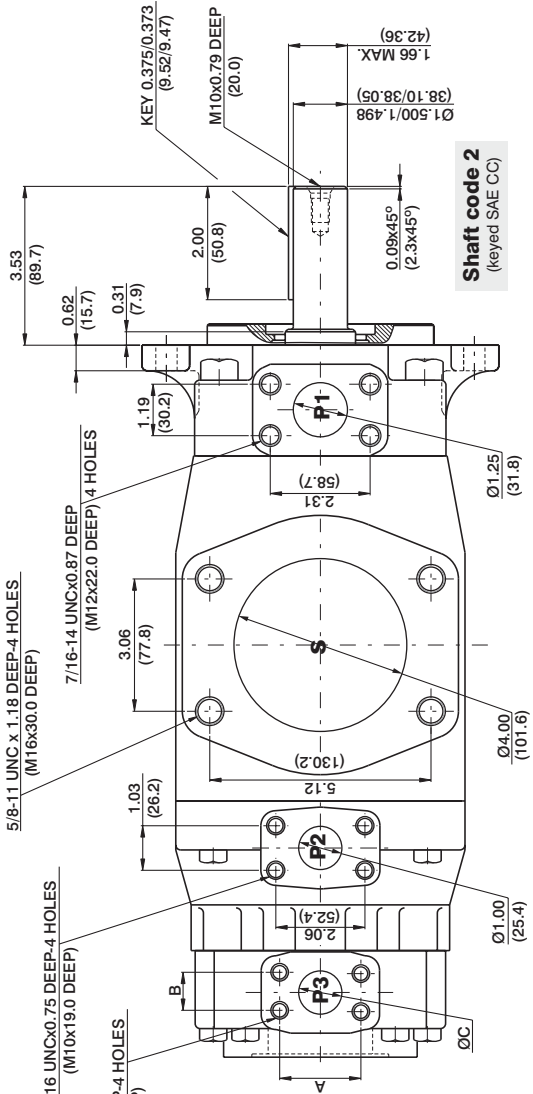

PORT	CODE	A	B	C
P3	00 & M0	2.06 (52.4)	1.03 (26.2)	1.00 (25.4)
	01 & M1	1.874 (47.6)	0.874 (22.2)	0.75 (19.05)

Shaft torque limits in³/rev x psi (ml/rev x bar)

Shaft	V x P max.	Coupling drive	V x P max.
2	58842 (66500)	SAE'A'	3061 (3456)
3	54207 (61200)		

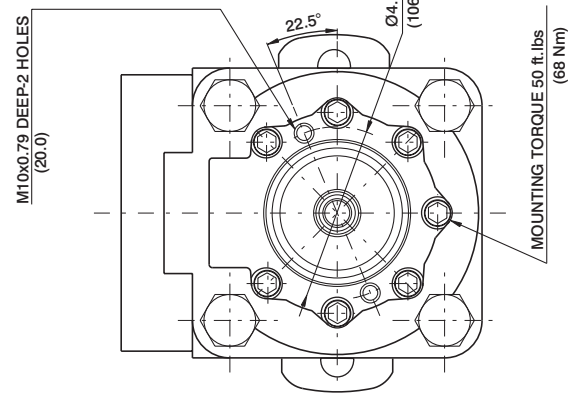
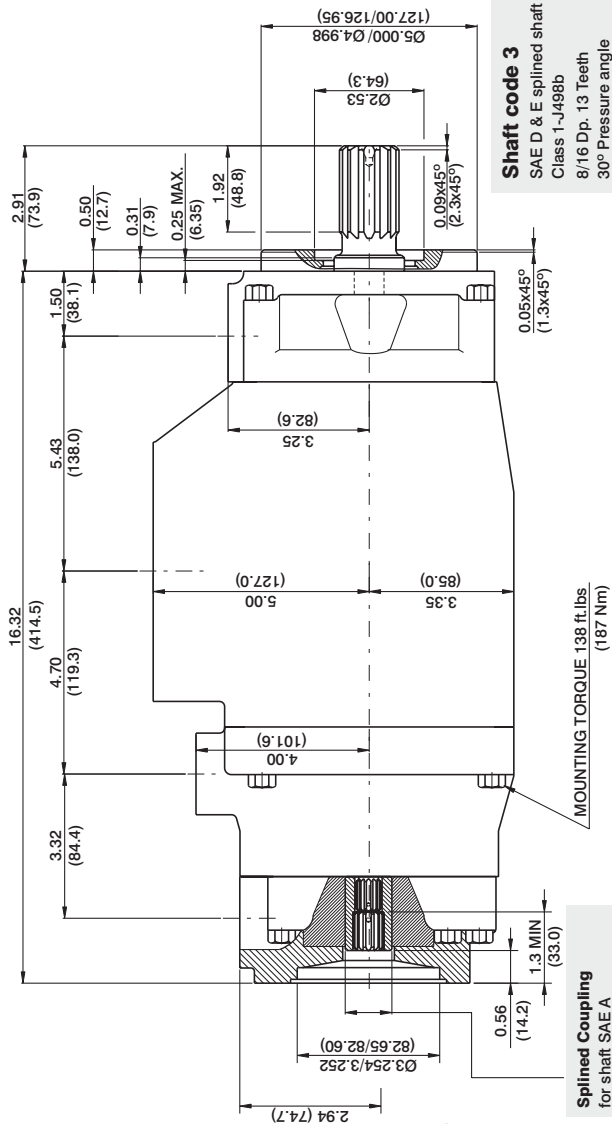
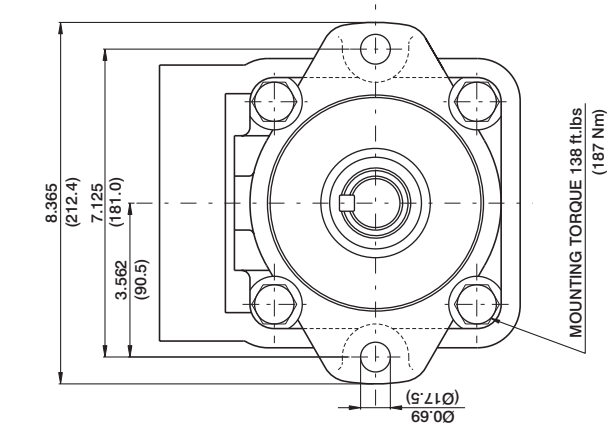

VT6DR * - 045 - 1 R 00 - A 1 0 - A 1 *

Series

Y- Metric port connection, Omit for UNC

Cam ring for

Volumetric displacement cm^3/rev (in^3/rev)

*014/B14 = 47.6 (2.90)	035/B35 = 111.0 (6.77)
017/B17 = 58.2 (3.55)	038/B38 = 120.3 (7.34)
020/B20 = 66.0 (4.03)	042/B42 = 136.0 (8.30)
024/B24 = 79.5 (4.85)	045/B45 = 145.7 (8.89)
028/B28 = 89.7 (5.47)	050/B50 = 158.0 (9.64)
031/B31 = 98.3 (6.00)	061/B61 = 190.5 (11.62)

*0' - Uni - directional 'B' - Bi - directional

Type of Shaft

- 1 - Keyed (SAE C)
- 2 - Keyed (SAE CC)
- 3 - Splined (SAE C)
- 5 - Keyed (no SAE)

Direction of rotation (view on shaft end)

- R - Clockwise
- L - Counter - clockwise

Porting combination

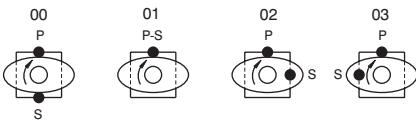

Modifications

Seal class

- 1 - S1 (for mineral oil)
- 4 - S4 (for fire resistant fluids)
- 5 - S5 (for mineral oil and fire resistant fluids)

Design letter

Porting adapter

Coupling

- 1 - SAE A
- 2 - SAE B
- 3 - SAE BB
- 4 - SAE C
- 5 - SAE J498b
- 16/32-11 teeth

Adapter

- 0 - None
- A - SAE A
- B - SAE B
- C - SAE C

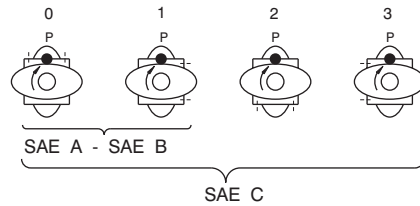

INTERNAL LEAKAGE (TYPICAL)

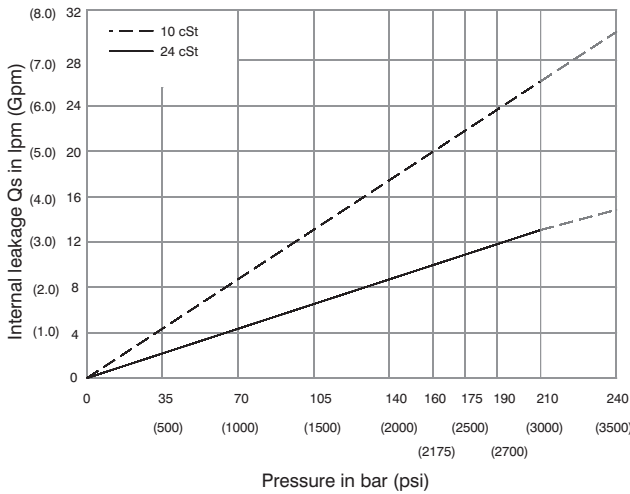

NOISE LEVEL (TYPICAL)

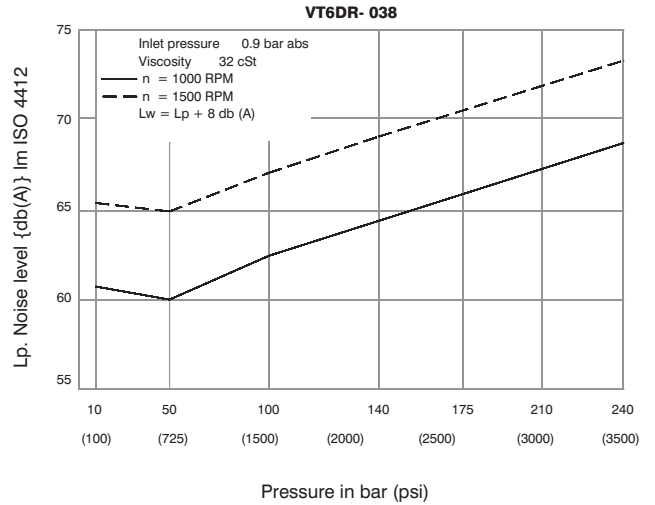

HYDROMECHANICAL POWER LOSS (TYPICAL)

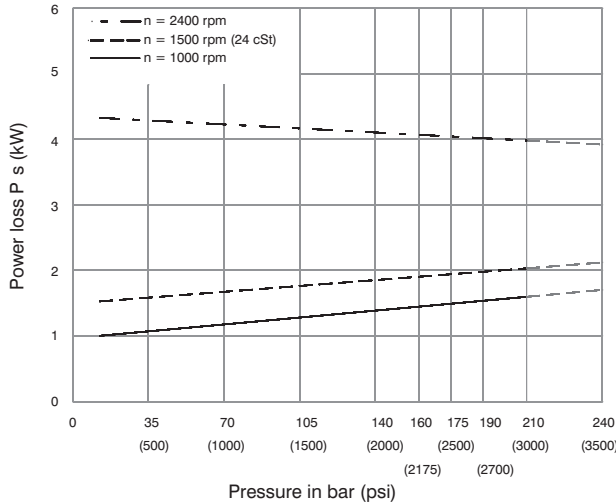

PERMISSIBLE RADIAL LOAD

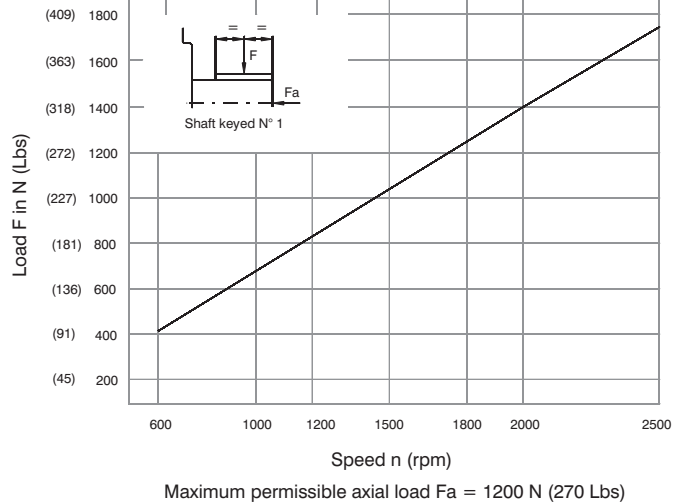

VT6DRM * - B45 - 1 R 00 - A 1 0 - A 1 *

Series

Y- Metric port connection, Omit for UNC

Cam ring for

Volumetric displacement cm^3/rev (in^3/rev)

* B14/R14 = 47.6 (2.90)	B35/R35 = 110.0 (6.77)
B17/R17 = 58.2 (3.55)	B38/R38 = 120.3 (7.34)
B20/R20 = 66.0 (4.03)	B42/R42 = 136.0 (8.30)
B24/R24 = 79.5 (4.85)	B45/R45 = 145.7 (8.89)
B28/R28 = 89.7 (5.47)	B50/R50 = 158.0 (9.64)
B31/R31 = 98.3 (6.00)	B61/R61 = 190.5 (11.62)

* 'B' - for Mobile
'R' - for Mobile - spring assisted

Type of Shaft

- 1 - Keyed (SAE C)
- 2 - Keyed (SAE CC)
- 3 - Splined (SAE C)
- 5 - Keyed (no SAE)

Direction of rotation (view on shaft end)

- R - Clockwise
- L - Counter - clockwise

Porting combination

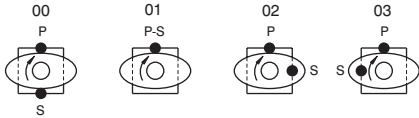

Modifications

Seal class

- 1 - S1 (for mineral oil)
- 4 - S4 (for fire resistant fluids)
- 5 - S5 (for mineral oil and fire resistant fluids)

Design letter

Porting adapter

Coupling

- 1 - SAE A
- 2 - SAE B
- 3 - SAE BB
- 4 - SAE C
- 5 - SAE J498b
- 16/32-11 teeth

Adapter

- 0 - None
- A - SAE A
- B - SAE B
- C - SAE C

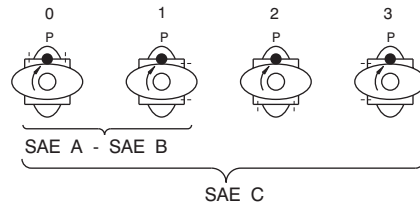

INTERNAL LEAKAGE (TYPICAL)

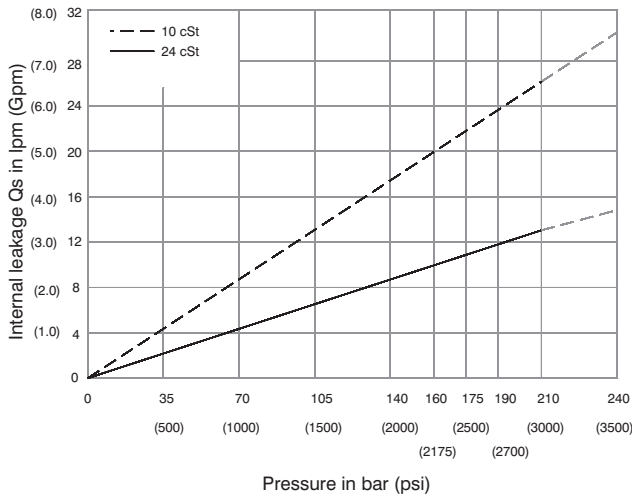

NOISE LEVEL (TYPICAL)

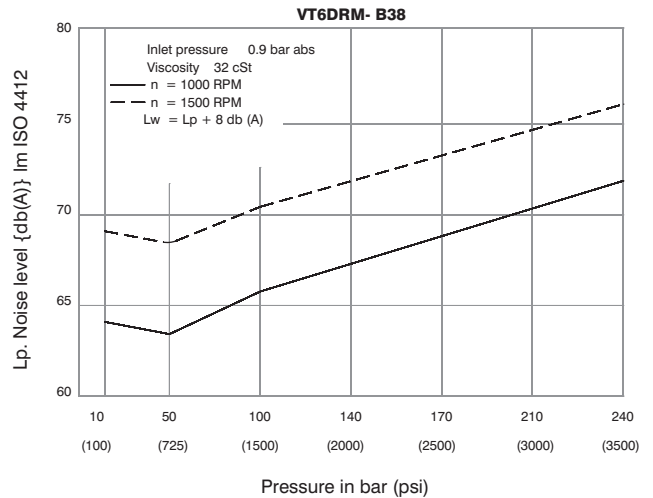

HYDROMECHANICAL POWER LOSS (TYPICAL)

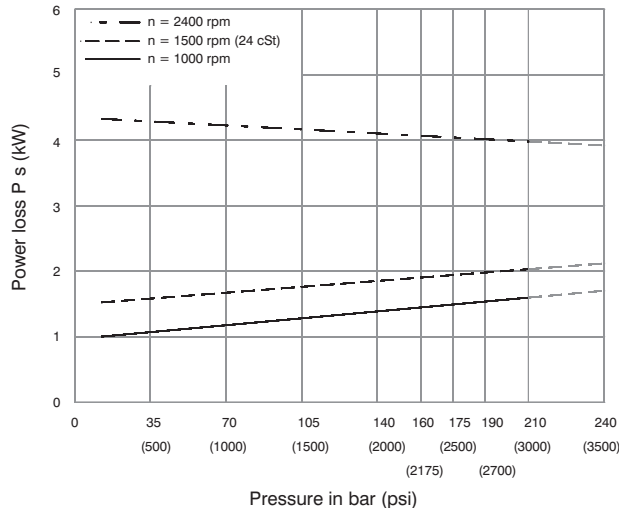

PERMISSIBLE RADIAL LOAD

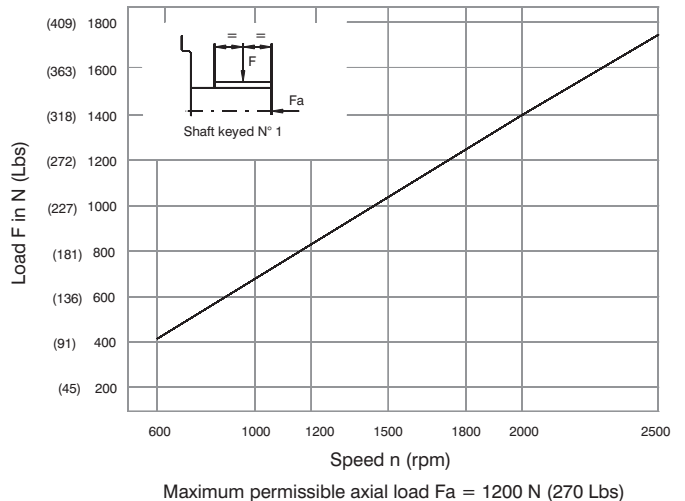

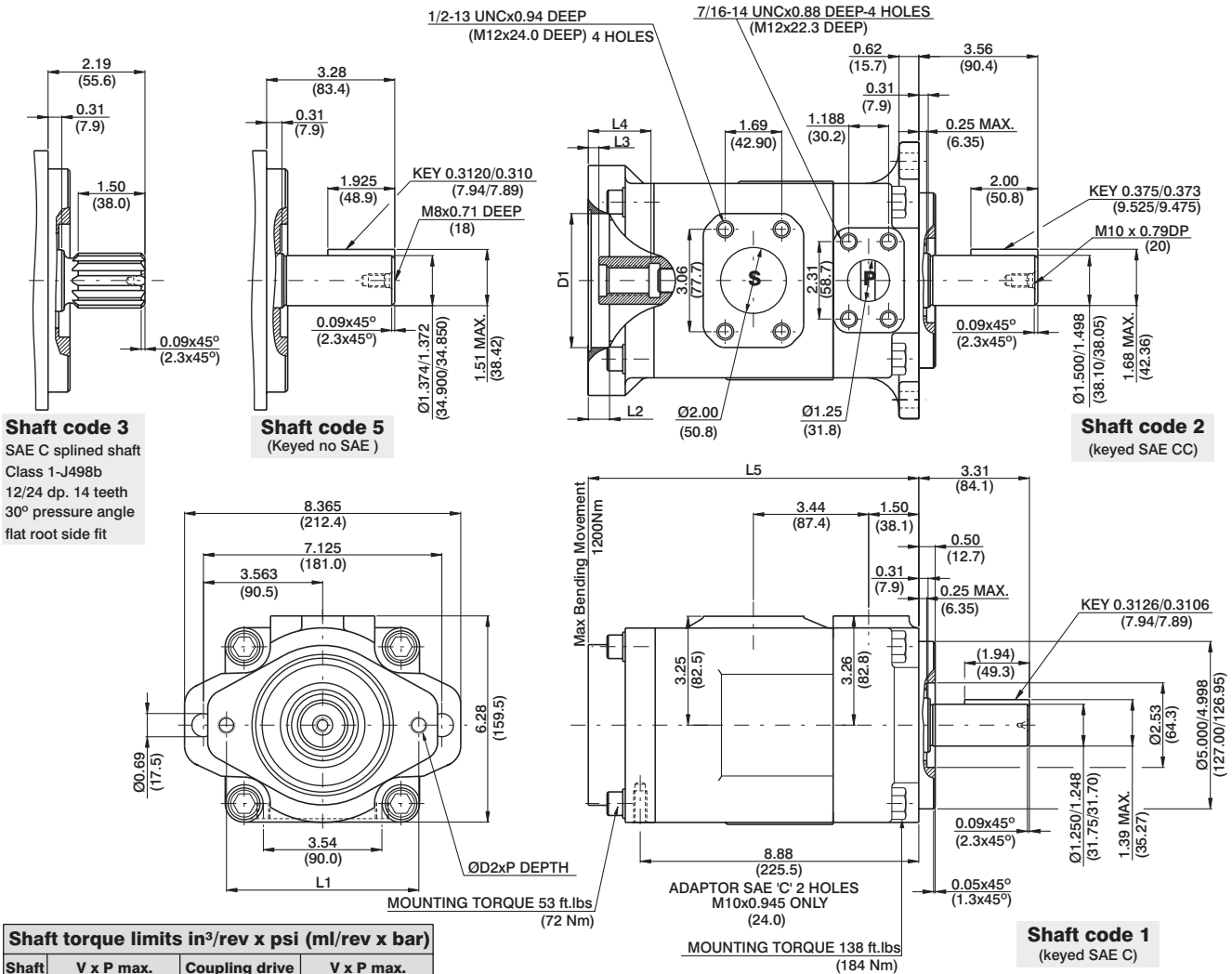

Shaft torque limits in³/rev x psi (ml/rev x bar)

Shaft	V x P max.	Coupling drive	V x P max.
1	38300 (43240)	SAE"A"	9743 (11000)
2	58491 (66036)	SAE"B"	18246 (20600)
3	54207 (61200)	SAE"BB"	28937 (32670)
5	49247 (55600)	SAE"C"	33118 (37390)
		SAE"11teeth"	14039 (15850)

Adaptor	D1	D2	P	L1	L2	L3	L4	L5
SAE "A"	3.25 (82.60)	M10	0.94 (24)	4.19 (106.4)	0.43 (11)	0.31 (7.9)	1.26 (32)	9.33 (237)
SAE "B"	4.00 (101.65)	M12	1.10 (28)	5.75 (146.0)	0.63 (16)	0.31 (7.9)	1.81 (46)	9.88 (251)
SAE "C"	5.00 (127.10)	M16	-	7.12 (181.0)	0.63 (16)	0.31 (7.9)	2.20 (56)	10.27 (261)

Adaptor	SAE "A"			SAE "B"		SAE "C"
	SAE A	SAE (11teeth)	SAE B	SAE B	SAE BB	SAE C
Number of teeth	9	11	13	13	15	14
Pitch	16/32	16/32	16/32	16/32	16/32	12/24
Pressure angle	30°	30°	30°	30°	30°	30°
Major dia.(min)	0.625 (15.875)	0.750 (19.05)	0.875 (22.225)	0.875 (22.225)	1.00 (25.40)	1.250 (31.75)
Minor dia.(min)	0.500 (12.70)	0.630 (16.00)	0.753 (19.134)	0.753 (19.134)	0.877 (22.268)	1.086 (27.585)

OPERATING CHARACTERISTICS - TYPICAL (24 cST)

Pressure port	Series	Volumetric Displacement Vp		Flow q & n = 1500 rpm						Input power p & n = 1500 rpm					
		in ³ /rev	cm ³ /rev	p = 0 bar (0 psi)		p = 140 bar (2000 psi)		p = 240 bar (3500 psi)		p = 7 bar (100 psi)		p = 140 bar (2000 psi)		p = 240 bar (3500 psi)	
				gpm	lpm	gpm	lpm	gpm	lpm	hp	kw	hp	kw	hp	kw
VT6DRM	B14	2.90	47.6	18.88	71.4	16.42	62.1	14.78	55.9	3.08	2.3	24.81	18.5	41.03	30.6
	B17	3.55	58.2	23.1	87.3	20.6	78.0	18.99	71.8	3.35	2.5	29.77	22.2	49.62	37.0
	B20	4.00	66.0	26.19	99.0	23.73	89.7	22.08	83.5	3.75	2.8	33.39	24.9	55.92	41.7
	B24	4.80	79.5	31.56	119.3	29.10	110.0	27.46	103.8	4.02	3.0	39.69	29.6	66.78	49.8
	B28	5.50	89.7	35.58	134.5	33.12	125.2	31.48	119.0	4.29	3.2	44.52	33.2	74.96	55.9
	B31	6.00	98.3	39.00	147.5	36.53	138.1	34.89	131.9	4.42	3.3	48.54	36.2	81.80	61.0
	B35	6.80	111.0	44.04	166.5	41.58	157.2	39.94	151.0	4.69	3.5	54.58	40.7	92.13	68.7
	B38	7.30	120.3	47.72	180.4	45.26	171.1	43.62	164.9	4.96	3.7	58.87	43.9	99.64	74.3
	B42 ¹⁾	8.30	136.0	53.96	204.0	51.50	194.7	49.86	188.5	5.36	4.0	66.25	49.4	112.24	83.7
	B45 ¹⁾	8.89	145.7	57.80	218.5	55.34	209.2	53.70	203.0	5.50	4.1	70.81	52.8	120.02	89.5
	B50 ¹⁾	9.64	158.0	62.69	237.0	60.23	227.7	59.25 ²⁾	224.0 ²⁾	5.90	4.4	76.44	57.0	113.98 ²⁾	85.0 ²⁾
	B61 ¹⁾	11.62	190.5	76.25	285.7	73.54 ³⁾	278.0 ³⁾	--	--	6.16	4.6	81.26 ³⁾	60.6 ³⁾	--	--

1) B42-B45-B50-B61 = 2200 RPM max.

2) B50 = 210 bar (3000 psi) max.

3) B61 = 120 bar (1740 psi) max. int., B61 = 80 bar (1160 psi) cont.



VT6EDCR - 062 - 035 - 017 - 1 R 00 - A 1 - P - 00 - *

Series

Rear cap end for mounting
SAE "A" auxiliary pump
coupling adaptor SAE "A" -9 teeth

P1

P2

P3

Cam ring for "P1"

Volumetric displacement cm³/rev (in³/rev)

042 = 132.3 (8.07)	062 = 196.7 (12.00)
045 = 142.4 (8.69)	066 = 213.3 (13.02)
050 = 158.5 (9.67)	072 = 227.1 (13.86)
052 = 164.8 (10.06)	085 = 269.8 (16.46)
057 = 180.7 (11.02)	

Cam ring for "P2"

Volumetric displacement cm³/rev (in³/rev)

* 014/B14 = 47.6 (2.90)	035/B35 = 111.0 (6.77)
017/B17 = 58.2 (3.55)	038/B38 = 120.3 (7.34)
020/B20 = 66.0 (4.03)	042/B42 = 136.0 (8.30)
024/B24 = 79.5 (4.85)	045/B45 = 145.7 (8.89)
028/B28 = 89.7 (5.47)	050/B50 = 158.0 (9.64)
031/B31 = 98.3 (6.00)	061/B61 = 190.5 (11.62)

*0' - Uni - directional 'B' - Bi - directional

Cam ring for "P3"

Volumetric displacement cm³/rev (in³/rev)

*003/B03 = 10.8 (0.66)	015/B15 = 50.5 (3.08)
005/B05 = 17.2 (1.05)	017/B17 = 58.3 (3.56)
006/B06 = 21.3 (1.30)	020/B20 = 63.8 (3.89)
008/B08 = 26.4 (1.61)	022/B22 = 70.3 (4.29)
010/B10 = 34.1 (2.08)	025/B25 = 79.3 (4.84)
012/B12 = 37.1 (2.26)	028/B28 = 88.8 (5.42)
014/B14 = 46.0 (2.81)	031/B31 = 100.0 (6.10)

*0' - Uni - directional 'B' - Bi - directional

Modifications

Mounting w/connection variables

00 = P3 = 1" SAE
01 = P3 = 3/4" SAE

Mounting (pump)

P= Pedestal mounting
F= Face mounting

Seal class

1 - S1 (for mineral oil)
4 - S4 (for fire resistant fluids)
5 - S5 (for mineral oil and fire resistant fluids)

Design letter

Porting combination (see page DI-1-13)

00 = Standard

Direction of rotation (view on shaft end)

R - Clockwise
L - Counter - clockwise

Type of Shaft

1 - Keyed (G45N-ISO 3019-2)
3 - Splined (SAE D & E)



OPERATING CHARACTERISTICS - TYPICAL (24 cST) (Input power p (KW) for one cartridge only)

Pressure port	Series	Volumetric Displacement Vp		Flow q & n = 1500 rpm						Input power p & n = 1500 rpm					
		in ³ /rev	cm ³ /rev	p = 0 bar (0 psi)		p = 140 bar (2000 psi)		p = 240 bar (3500 psi)		p = 7 bar (100 psi)		p = 240 bar (3500 psi)			
				gpm	lpm	gpm	lpm	gpm	lpm	hp	kw	hp	kw		
P1	042	8.07	132.3	52.50	198.5	49.87	188.5	47.96	181.3	6.97	5.2	66.25	49.4	110.77	82.6
	045	8.70	142.4	56.51	213.6	53.86	203.6	51.98	196.5	7.24	5.4	70.94	52.9	118.95	88.7
	050	9.67	158.5	62.88	237.7	60.24	227.7	58.36	220.6	7.64	5.7	78.45	58.5	131.82	98.3
	052	10.00	164.8	65.40	247.2	62.75	237.2	60.87	230.1	7.78	5.8	81.53	60.8	136.92	102.1
	057	11.02	180.7	71.71	271.1	69.07	261.1	67.19	254.0	8.18	6.1	89.04	66.4	143.35	106.9
	062	12.00	196.7	78.04	295.0	75.40	285.0	73.52	277.9	8.58	6.4	96.42	71.9	162.67	121.3
	066	13.00	213.3	84.63	319.9	81.98	309.9	80.11	302.8	8.98	6.7	104.20	77.7	175.94	131.2
	072	13.86	227.1	90.11	340.6	87.46	330.6	85.58	323.5	9.25	6.9	110.77	82.6	187.07	139.5
	085 ¹⁾	16.40	269.8	107.00	404.7	105.21 ²⁾	397.7 ²⁾	--	--	9.78	7.3	87.56 ²⁾	65.3 ²⁾	--	--
P2	014	2.90	47.6	18.88	71.4	16.42	62.1	14.78	55.9	3.08	2.3	24.81	18.5	41.03	30.6
	017	3.55	58.2	23.09	87.3	20.63	78.0	18.99	71.8	3.35	2.5	29.75	22.2	49.60	37.0
	020	4.00	66.0	26.19	99.0	23.73	89.7	22.08	83.5	3.75	2.8	33.39	24.9	55.92	41.7
	024	4.80	79.5	31.56	119.3	29.10	110.0	27.46	103.8	4.02	3.0	39.69	29.6	66.78	49.8
	028	5.50	89.7	35.58	134.5	33.12	125.2	31.48	119.0	4.29	3.2	44.52	33.2	74.96	55.9
	031	6.00	98.3	39.00	147.5	36.53	138.1	34.89	131.9	4.42	3.3	48.54	36.2	81.80	61.0
	035	6.80	111.0	44.04	166.5	41.58	157.2	39.94	151.0	4.69	3.5	54.58	40.7	92.13	68.7
	038	7.30	120.3	47.72	180.4	45.26	171.1	43.62	164.9	4.96	3.7	58.87	43.9	99.64	74.3
	042	8.30	136.0	53.96	204.0	51.50	194.7	49.86	188.5	5.36	4.0	66.25	49.4	112.24	83.7
	045	8.89	145.7	57.80	218.5	55.34	209.2	53.70	203.0	5.50	4.1	70.81	52.8	120.02	89.5
	050	9.64	158.0	62.69	237.0	60.23	227.7	59.25 ³⁾	224.0 ³⁾	5.90	4.4	76.44	57.0	113.98 ³⁾	85.0 ³⁾
P3	061	11.62	190.5	76.25	285.7	73.54 ⁴⁾	278.0 ⁴⁾	--	--	6.16	4.6	81.26 ⁴⁾	60.6 ⁴⁾	--	--
	003	0.66	10.8	4.29	16.2	2.96	11.2	2.04	7.7	1.74	1.3	7.11	5.3	11.22	8.4
	005	1.05	17.2	6.83	25.8	5.50	20.8	4.57	17.3	1.88	1.4	10.06	7.5	16.36	12.2
	006	1.30	21.3	8.44	31.9	7.11	26.9	6.19	23.4	2.01	1.5	11.94	8.9	19.71	14.7
	008	1.61	26.4	10.48	39.6	9.15	34.6	8.22	31.1	2.15	1.6	14.35	10.7	22.93	17.7
	010	2.08	34.1	13.52	51.1	12.19	46.1	11.26	42.6	2.28	1.7	18.64	13.4	29.90	22.3
	012	2.26	37.1	14.71	55.6	13.36	50.6	12.46	47.1	2.28	1.7	19.31	14.4	32.32	24.1
	014	2.81	46.0	18.25	69.0	16.93	64.0	16.00	60.5	2.55	1.9	23.60	17.6	39.56	29.5
	015	3.08	50.5	20.00	75.6	18.73	73.2	19.02	67.5	2.68	2.0	25.61	19.1	42.91	32.0
	017	3.56	58.3	23.12	87.4	21.79	82.4	20.87	78.9	2.82	2.1	29.37	21.9	49.48	36.9
	020	3.89	63.8	25.32	95.7	23.99	90.7	23.07	87.2	2.95	2.2	31.92	23.8	53.91	40.2
	022	4.29	70.3	27.88	105.4	26.56	100.4	25.63	96.9	3.08	2.3	35.00	26.1	59.14	44.1
	025	4.84	79.3	31.46	118.9	30.13	113.9	29.21	110.4	3.35	2.5	39.16	29.2	66.38	49.5
	028	5.42	88.8	35.24	133.2	33.92	128.2	33.28 ⁴⁾	125.8 ⁴⁾	3.75	2.8	43.85	32.7	65.04 ⁴⁾	48.5 ⁴⁾
	031	6.10	100.0	39.68	150.0	38.35	145.0	37.72 ⁴⁾	142.6 ⁴⁾	3.75	2.8	48.95	36.5	72.95 ⁴⁾	54.4 ⁴⁾

1) 085 = 2000 RPM max.

2) 085 = 75 bar (1100 psi) cont.

085 = 90 bar (1300 psi) max. int.

3) 028-031-050=210 bar (3000 psi) max.

4) 061 = 120 bar (1740 psi) max. int., 061 = 80 bar (1160 psi) cont.

INTERNAL LEAKAGE (TYPICAL)

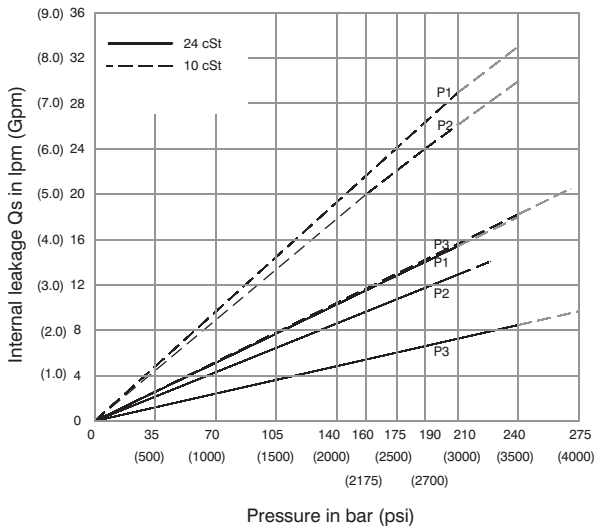

Total leakage is the sum of each section loss at its operating conditions.

NOISE LEVEL (TYPICAL)

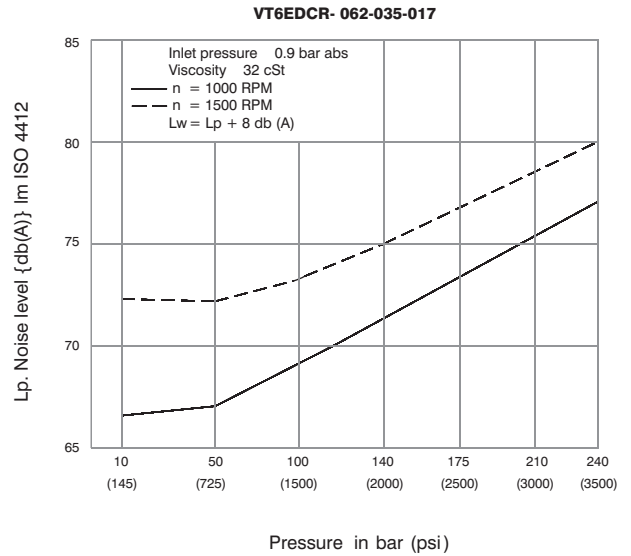

Triple pump noise level is given with each section discharging at the pressure noted on the curve.

HYDROMECHANICAL POWER LOSS (TYPICAL)

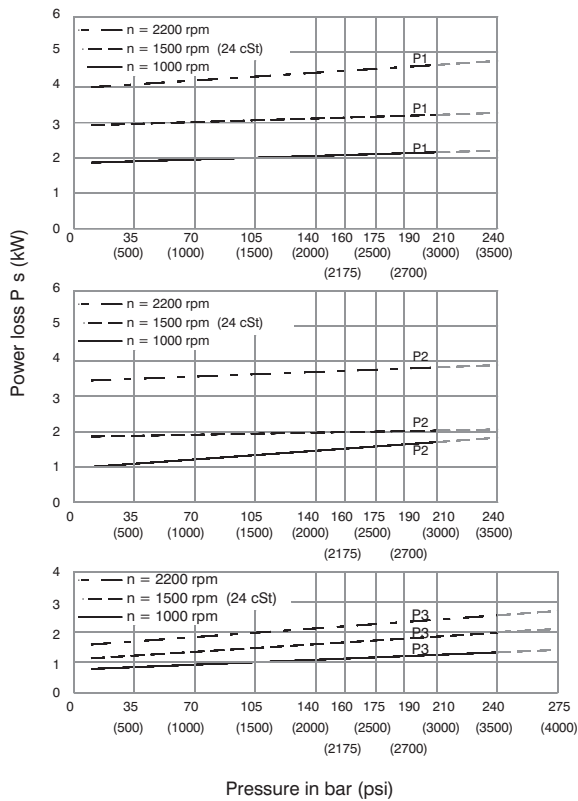

Total hydromechanical power loss is the sum of each section at its operating conditions

PERMISSIBLE RADIAL LOAD

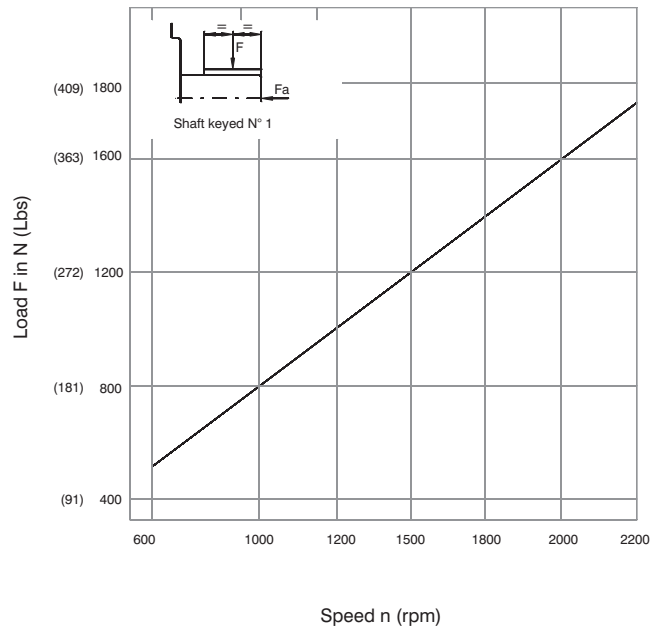

Maximum axial load permissible $F_a = 2000N$ (449 lbs)



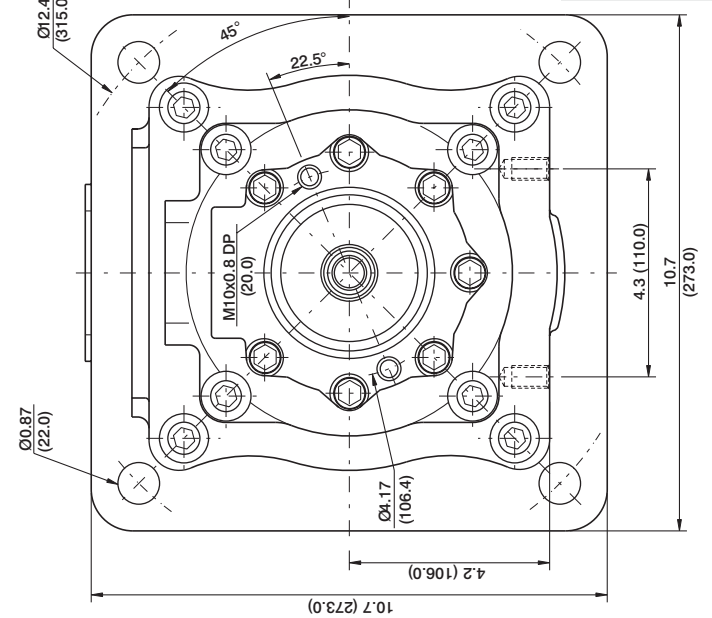
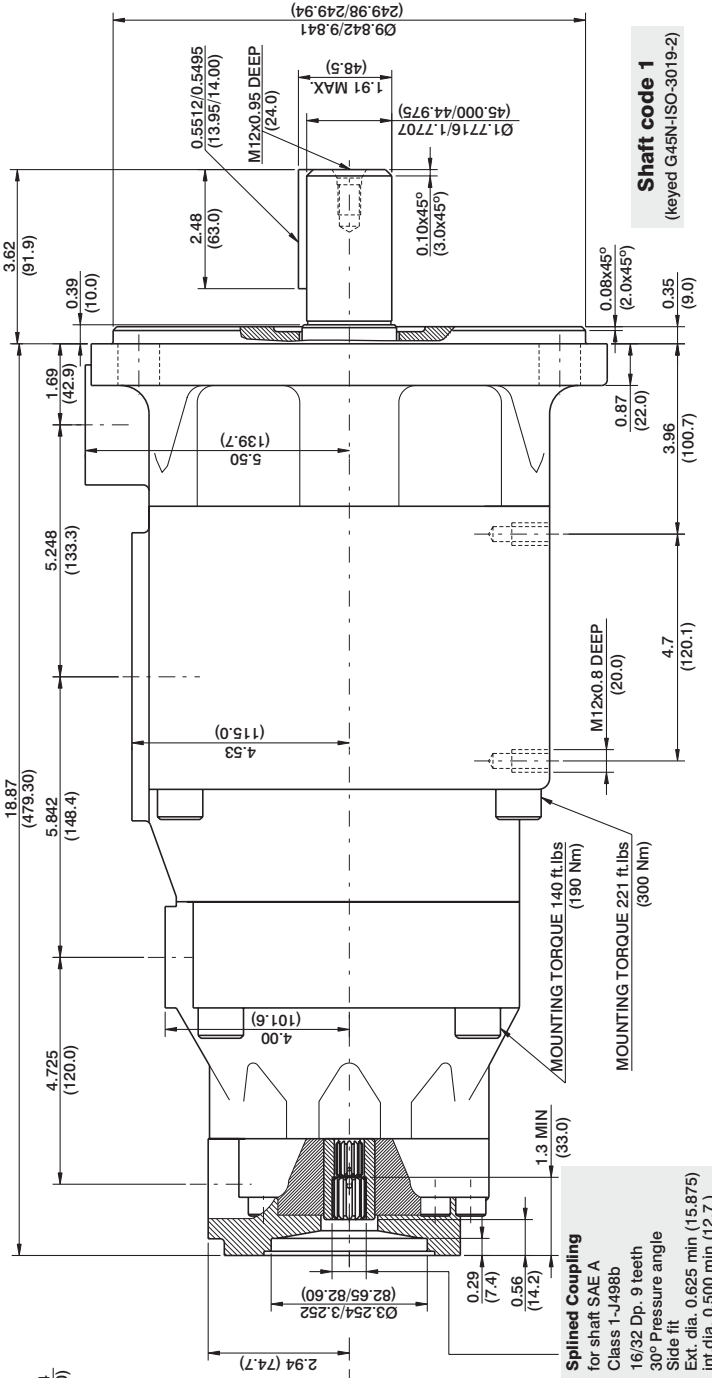
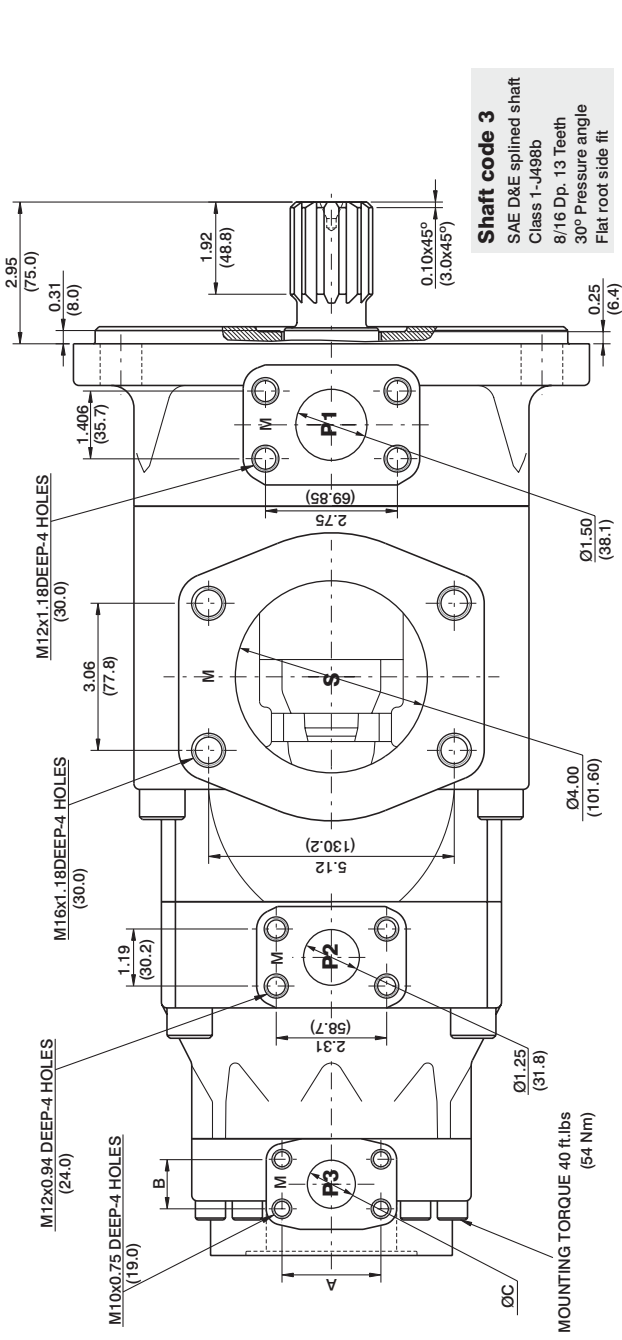

PORT CODE	A	B	C
P3	00	2.06 (52.4)	1.03 (26.2)
	01	1.874 (47.6)	0.874 (22.2)

Shaft torque limits in ³ /rev x psi (ml/rev x bar)	Coupling drive	SAE'A'
V x P max. P1+P2+P3	V x P max.	3061 (3456)
3	54207 (61200)	3061 (3456)



VT6EE / VT6EES - 066 - 045 - 1 R 00 - B 1 0 - 00 *

Series

VT6EE Series - 250 B4HW

ISO 3019-2 mounting flange

VT6EES Series - SAE 4 bolts

Mounting flange J744c

Cam ring for "P1" & "P2"

Volumetric displacement cm³/rev (in³/rev)

042 = 132.3 (8.07)

045 = 142.4 (8.69)

050 = 158.5 (9.67)

052 = 164.8 (10.06)

057 = 180.7 (11.02)

062 = 196.7 (12.00)

066 = 213.3 (13.02)

072 = 227.1 (13.86)

085 = 269.8 (16.46)

Type of Shaft VT6EE

2 - Keyed (G45N ISO 3019-2)

VT6EES

1 - Keyed (SAE CC)

3 - Splined (SAE CC)

4 - Splined (SAE D&E)

5 - Keyed (SAE D&E)

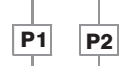

Modifications

Port connection variables

SAE 4 bolt flange (J518c)

	UNC	METRIC
VT6EE		M0
VT6EES	00	M0

Coupling adaptor

- 0 - None
- 2 - SAE B
- 3 - SAE BB

Seal class

- 1 - S1 (for mineral oil)
- 4 - S4 (for fire resistant fluids)
- 5 - S5 (for mineral oil and fire resistant fluids)

Design letter

Porting combination (see page BM-1-5)

00 = Standard

Direction of rotation (View on shaft end)

- R - Clockwise
- L - Counter - clockwise

INTERNAL LEAKAGE (TYPICAL)

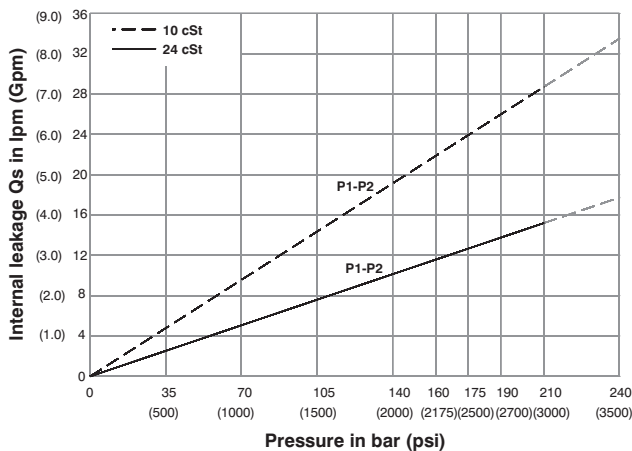

Do not operate pump more than 5 seconds at any speed or viscosity if internal leakage is more than 50% of theoretical flow. Total leakage is the sum of each section loss at its operating conditions.

NOISE LEVEL (TYPICAL)

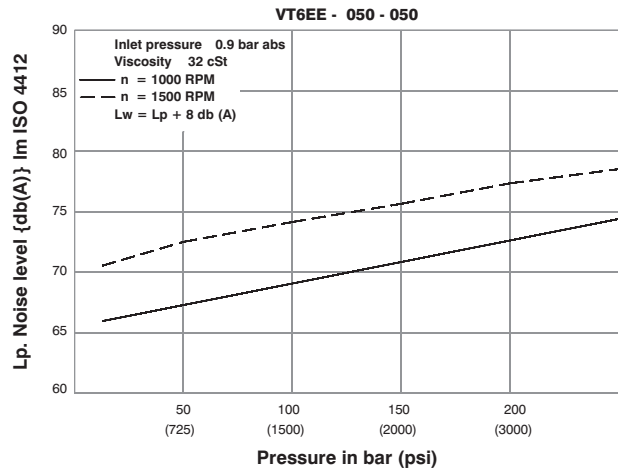

Double pump noise level is given with each section discharging at the pressure noted on the curve.

HYDROMECHANICAL POWER LOSS (TYPICAL)

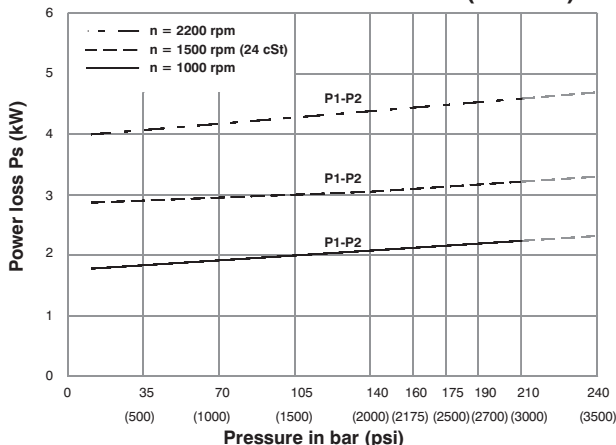

Total hydromechanical power loss is the sum of each section at its operating conditions.

PERMISSIBLE RADIAL LOAD

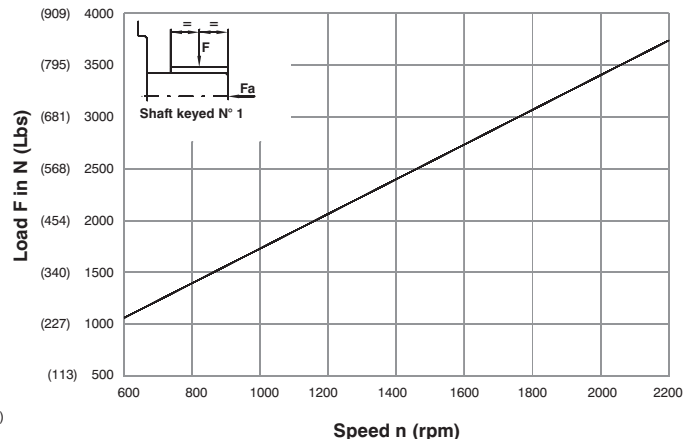

Maximum permissible axial load Fa = 2000 N (449 Lbs)



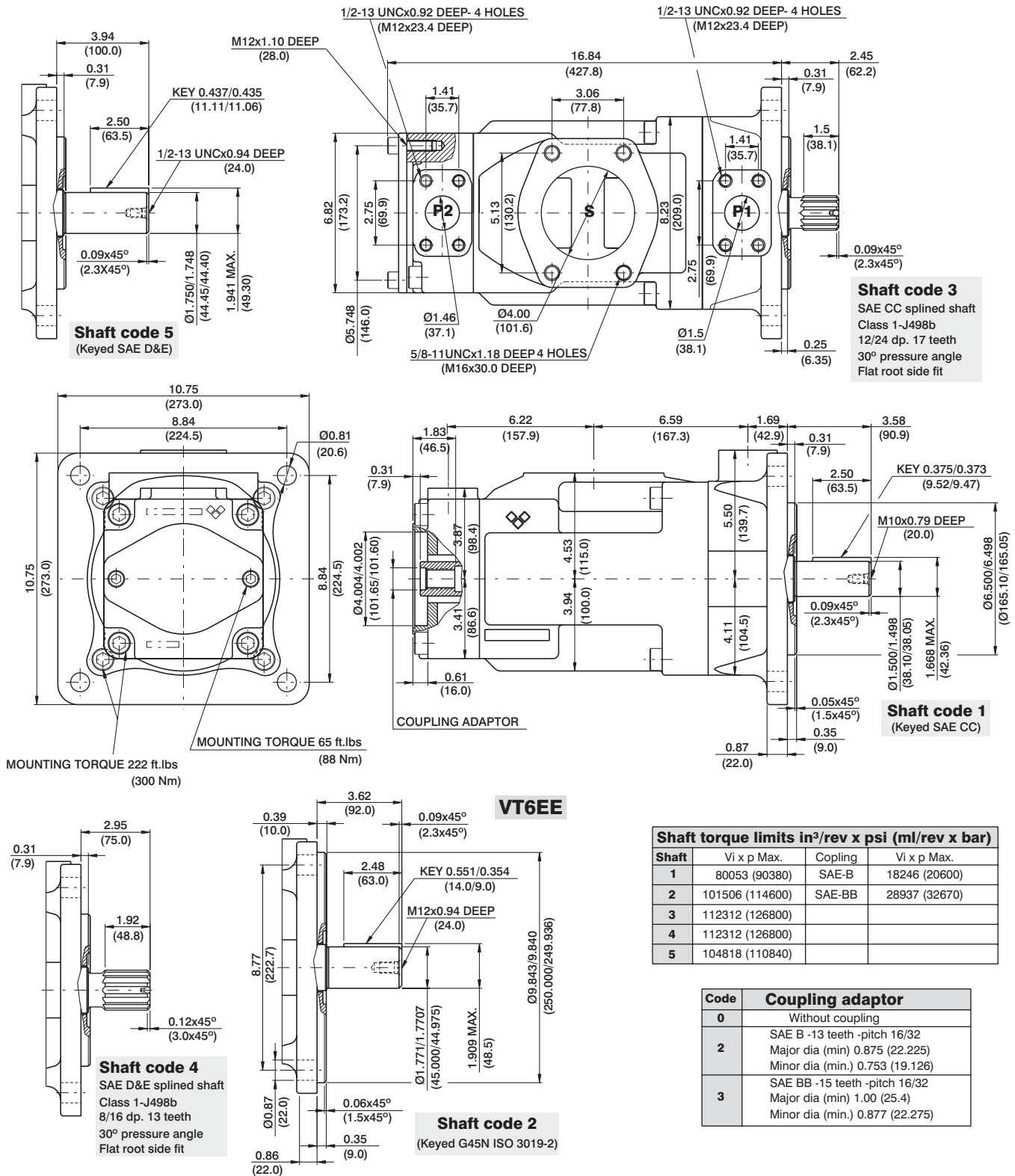

Shaft torque limits in ³ /rev x psi (ml/rev x bar)			
Shaft	Vi x p Max.	Coupling	Vi x p Max.
1	80053 (90380)	SAE-B	18246 (20600)
2	101506 (114600)	SAE-BB	28937 (32670)
3	112312 (126800)		
4	112312 (126800)		
5	104818 (110840)		

Code	Coupling adaptor
0	Without coupling
2	SAE B -13 teeth -pitch 16/32 Major dia (min) 0.875 (22.225) Minor dia (min) 0.753 (19.126)
3	SAE BB -15 teeth -pitch 16/32 Major dia (min) 1.00 (25.4) Minor dia (min) 0.877 (22.275)

OPERATING CHARACTERISTICS - TYPICAL (24 cST) (Input power p (KW) for one cartridge only)

Pressure port	Series	Volumetric Displacement Vp	Flow q & n = 1500 rpm						Input power p & n = 1500 rpm						
			p = 0 bar (0 psi)		p = 140 bar (2000 psi)		p = 240 bar (3500 psi)		p = 7 bar (100 psi)		p = 140 bar (2000 psi)		p = 240 bar (3500 psi)		
			in ³ /rev	cm ³ /rev	gpm	lpm	gpm	lpm	gpm	lpm	hp	kw	hp	kw	hp
P1 & P2	042	8.07	132.3	52.50	198.5	49.87	188.5	47.96	181.3	6.97	5.2	66.25	49.4	110.77	82.6
	045	8.70	142.4	56.51	213.6	53.86	203.6	51.98	196.5	7.24	5.4	70.94	52.9	118.95	88.7
	050	9.67	158.5	62.88	237.7	60.24	227.7	58.36	220.6	7.64	5.7	78.45	58.5	131.82	98.3
	052	10.00	164.8	65.40	247.2	62.75	237.2	60.87	230.1	7.78	5.8	81.53	60.8	136.92	102.1
	057	11.02	180.7	71.71	271.1	69.07	261.1	67.19	254.0	8.18	6.1	89.04	66.4	143.35	106.9
	062	12.00	196.7	78.04	295.0	75.40	285.0	73.52	277.9	8.58	6.4	96.42	71.9	162.67	121.3
	066	13.00	213.3	84.63	319.9	81.98	309.9	80.11	302.8	8.98	6.7	104.20	77.7	175.94	131.2
	072	13.86	227.1	90.11	340.6	87.46	330.6	85.58	323.5	9.25	6.9	110.77	82.6	187.07	139.5
	085 ¹⁾	16.40	269.8	107.00	404.7	105.21 ²⁾	397.7 ²⁾	--	--	9.78	7.3	87.56 ²⁾	65.3 ²⁾	--	--

1) 085 = 2000 RPM max.

2) 085 = 75 bar (1100 psi) cont. 085 = 90 bar (1300 psi) max. int.

VT6ER * - 066 - 1 R 00 - A 1 0 - A 1 *

Series

Y - Metric port connection, Omit for UNC

Cam ring for

Volumetric displacement cm³/rev (in³/rev)

042 = 132.3 (8.07)	062 = 196.7 (12.00)
045 = 142.4 (8.69)	066 = 213.3 (13.02)
050 = 158.5 (9.67)	072 = 227.1 (13.86)
052 = 164.8 (10.06)	085 = 269.8 (16.46)
057 = 180.7 (11.02)	

Type of Shaft

- 1 - Keyed (SAE CC)
- 3 - Splined (SAE C)
- 4 - Splined (SAE CC)

Direction of rotation (view on shaft end)

- R - Clockwise
- L - Counter - clockwise

Porting combination

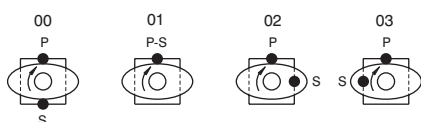

Modifications

Seal class

- 1 = S1 (for mineral oil)
- 4 = S4 (for fire resistant fluids)
- 5 = S5 (for mineral oil and fire resistant fluids)

Design letter

Porting adapter

Coupling

- 1 = SAE A
- 2 = SAE B
- 3 = SAE BB
- 4 = SAE C
- 5 = SAE J498b
- 16/32-11 teeth

Adapter

- 0 = None
- A = SAE A
- B = SAE B
- C = SAE C

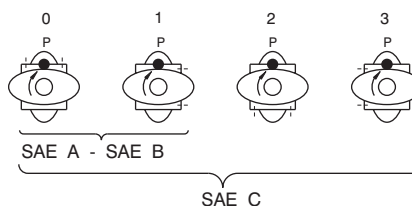

INTERNAL LEAKAGE (TYPICAL)

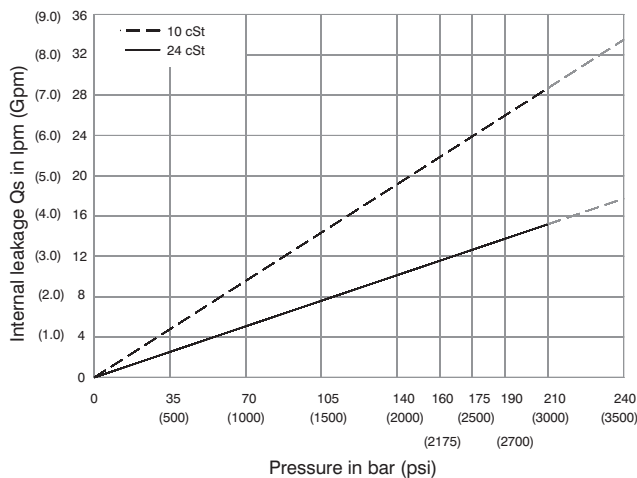

NOISE LEVEL (TYPICAL)

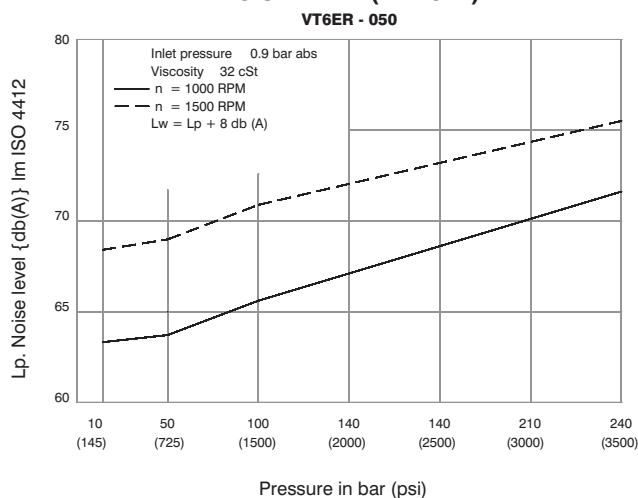

HYDROMECHANICAL POWER LOSS (TYPICAL)

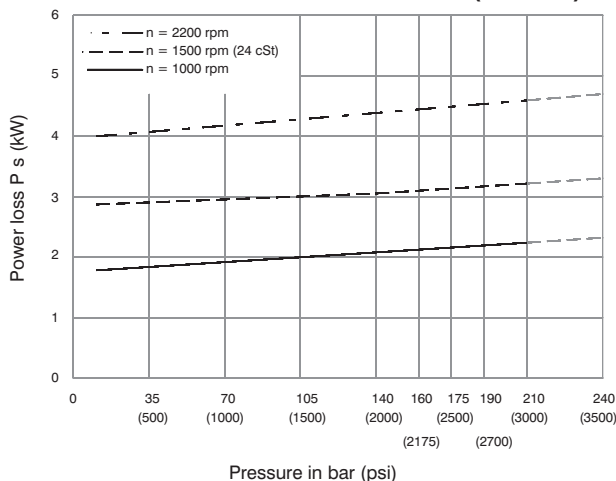

PERMISSIBLE RADIAL LOAD

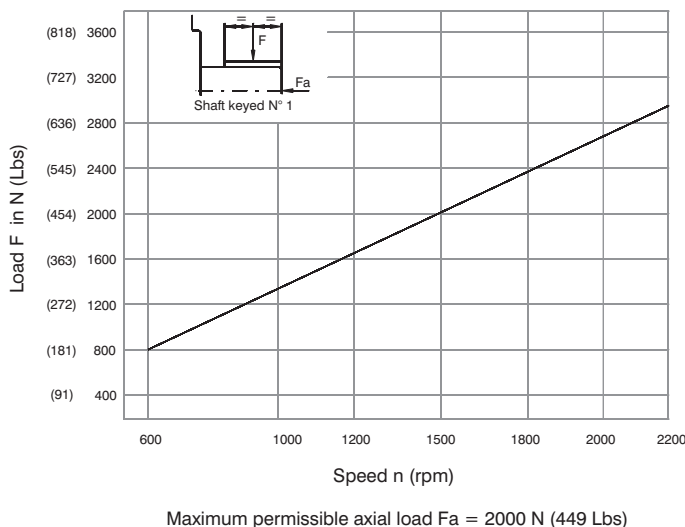

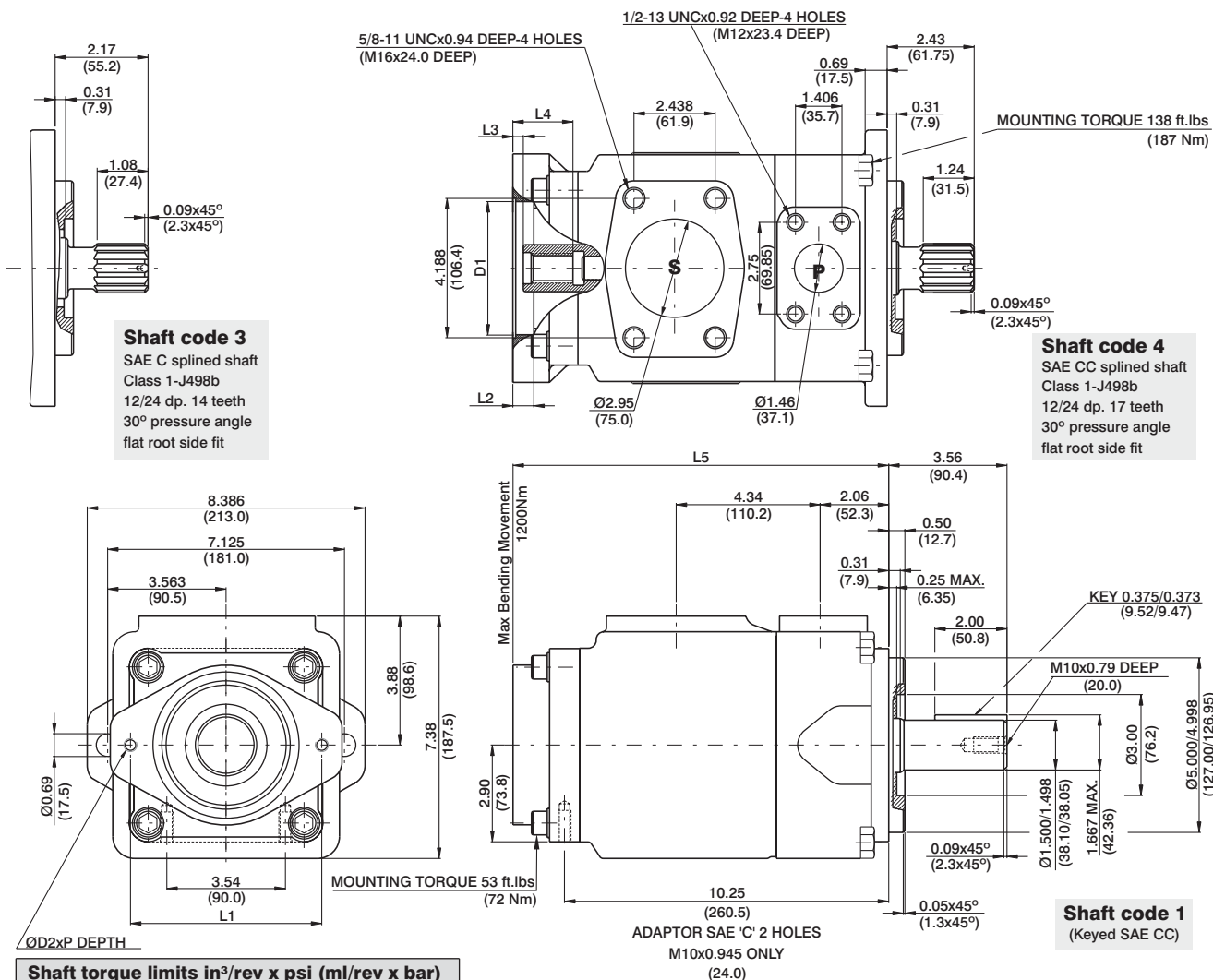

Shaft torque limits in³/rev x psi (ml/rev x bar)

Shaft	V x P max.	Coupling drive	V x P max.
1	71355 (80560)	SAE"A"	9743 (11000)
3	54207 (61200)	SAE"B"	18246 (20600)
4	106474 (120210)	SAE"BB"	28937 (32670)
		SAE"C"	58884 (66480)
		SAE"11teeth"	14039 (15850)

Adaptor	D1	D2	P	L1	L2	L3	L4	L5
SAE "A"	3.25 (82.60)	M10	0.94 (24)	4.19 (106.4)	0.43 (11)	0.31 (7.9)	1.26 (32)	10.71 (272)
SAE "B"	4.00 (101.65)	M12	1.10 (28)	5.75 (146.0)	0.63 (16)	0.31 (7.9)	1.81 (46)	11.26 (286)
SAE "C"	5.00 (127.10)	M16	-	7.12 (181.0)	0.63 (16)	0.31 (7.9)	2.20 (56)	11.65 (296)

Adaptor	SAE "A"			SAE "B"		SAE "C"
Coupling drive	SAE A	SAE (11teeth)	SAE B	SAE B	SAE BB	SAE C
Number of teeth	9	11	13	13	15	14
Pitch	16/32	16/32	16/32	16/32	16/32	12/24
Pressure angle	30°	30°	30°	30°	30°	30°
Major dia.(min)	0.625 (15.875)	0.750 (19.05)	0.875 (22.225)	0.875 (22.225)	1.00 (25.40)	1.250 (31.75)
Minor dia.(min)	0.500 (12.70)	0.630 (16.00)	0.753 (19.134)	0.753 (19.134)	0.877 (22.268)	1.086 (27.585)

OPERATING CHARACTERISTICS - TYPICAL (24 cST)

Pressure port	Series	Volumetric Displacement Vp		Flow q & n = 1500 rpm						Input power p & n = 1500 rpm					
		p = 0 bar (0 psi)		p = 140 bar (2000 psi)		p = 240 bar (3500 psi)		p = 7 bar (100 psi)		p = 140 bar (2000 psi)		p = 240 bar (3500 psi)			
		in ³ /rev	cm ³ /rev	gpm	lpm	gpm	lpm	gpm	lpm	hp	kw	hp	kw	hp	kw
VT6ER	042	8.07	132.3	52.50	198.5	49.87	188.5	47.96	181.3	6.97	5.2	66.25	49.4	110.77	82.6
	045	8.70	142.4	56.51	213.6	53.86	203.6	51.98	196.5	7.24	5.4	70.94	52.9	118.95	88.7
	050	9.67	158.5	62.88	237.7	60.24	227.7	58.36	220.6	7.64	5.7	78.45	58.5	131.82	98.3
	052	10.00	164.8	65.40	247.2	62.75	237.2	60.87	230.1	7.78	5.8	81.53	60.8	136.92	102.1
	057	11.02	180.7	71.71	271.1	69.07	261.1	67.19	254.0	8.18	6.1	89.04	66.4	143.35	106.9
	062	12.00	196.7	78.04	295.0	75.40	285.0	73.52	277.9	8.58	6.4	96.42	71.9	162.67	121.3
	066	13.00	213.3	84.63	319.9	81.98	309.9	80.11	302.8	8.98	6.7	104.20	77.7	175.94	131.2
	072	13.86	227.1	90.11	340.6	87.46	330.6	85.58	323.5	9.25	6.9	110.77	82.6	187.07	139.5
	085 ¹⁾	16.40	269.8	107.00	404.7	105.21 ²⁾	397.7 ²⁾	--	--	9.78	7.3	87.56 ²⁾	65.3 ²⁾	--	--

1) 085 = 2000 RPM max.

2) 085 = 75 bar (1100 psi) cont.

085 = 90 bar (1300 psi) max. int.

VT6ERM * - 066 - 1 R 00 - A 1 0 - A 1 *

Series

Y - Metric port connection, Omit for UNC

Cam ring for

Volumetric displacement cm^3/rev (in^3/rev)

*042/R42 = 132.3 (8.07)	062/R62 = 196.7 (12.00)
045/R45 = 142.4 (8.69)	066/R66 = 213.3 (13.02)
050/R50 = 158.5 (9.67)	072/R72 = 227.1 (13.86)
052/R52 = 164.8 (10.06)	085/R85 = 269.8 (16.46)
057/R57 = 180.7 (11.02)	

*R1 - for Mobile - spring assisted

Type of Shaft

- 1 - Keyed (SAE CC)
- 3 - Splined (SAE C)
- 4 - Splined (SAE CC)

Direction of rotation (view on shaft end)

- R - Clockwise
- L - Counter - clockwise

Porting combination

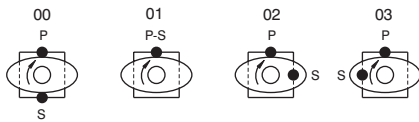

Modifications

Seal class

- 1 - S1 (for mineral oil)
- 4 - S4 (for fire resistant fluids)
- 5 - S5 (for mineral oil and fire resistant fluids)

Design letter

Porting adapter

Coupling

- 1 = SAE A
- 2 = SAE B
- 3 = SAE BB
- 4 = SAE C
- 5 = SAE J498b
- 16/32-11 teeth

Adapter

- 0 = None
- A = SAE A
- B = SAE B
- C = SAE C

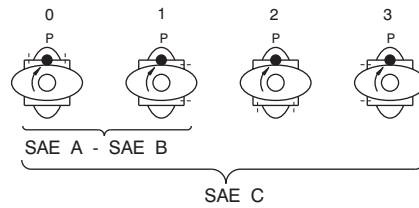

INTERNAL LEAKAGE (TYPICAL)

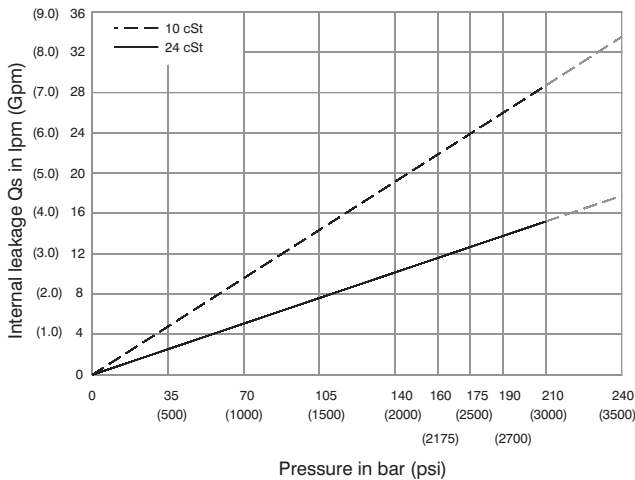

NOISE LEVEL (TYPICAL)

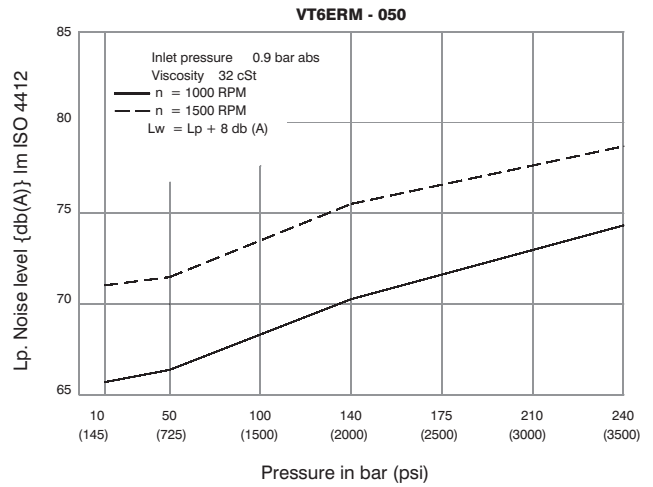

HYDROMECHANICAL POWER LOSS (TYPICAL)

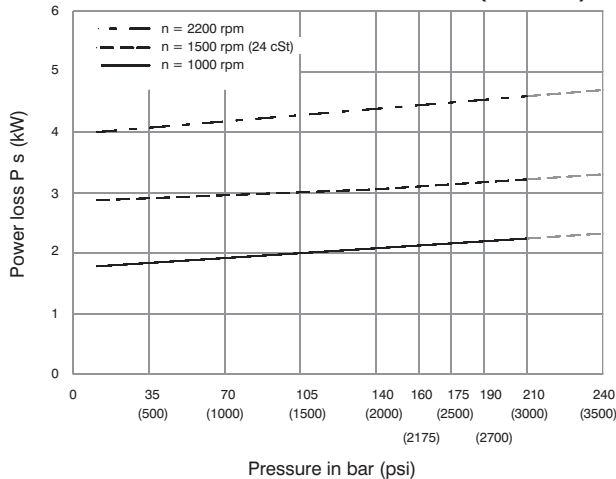

PERMISSIBLE RADIAL LOAD

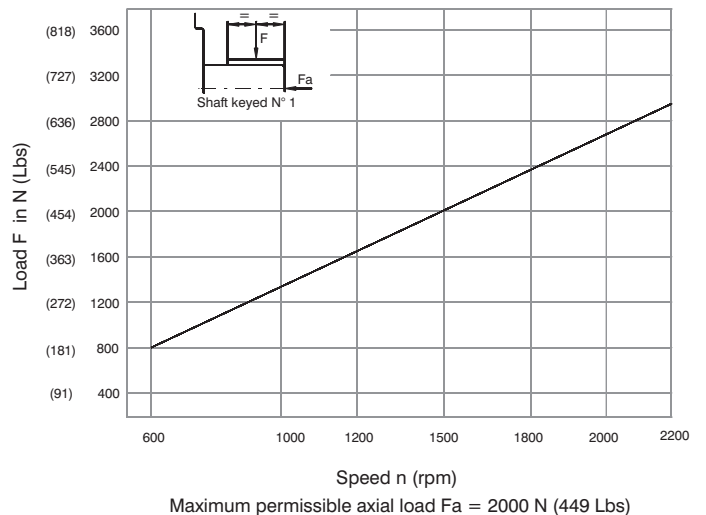

Maximum permissible axial load $F_a = 2000 \text{ N}$ (449 Lbs)



DRIVE TRAIN VANE PUMP VT6ERM

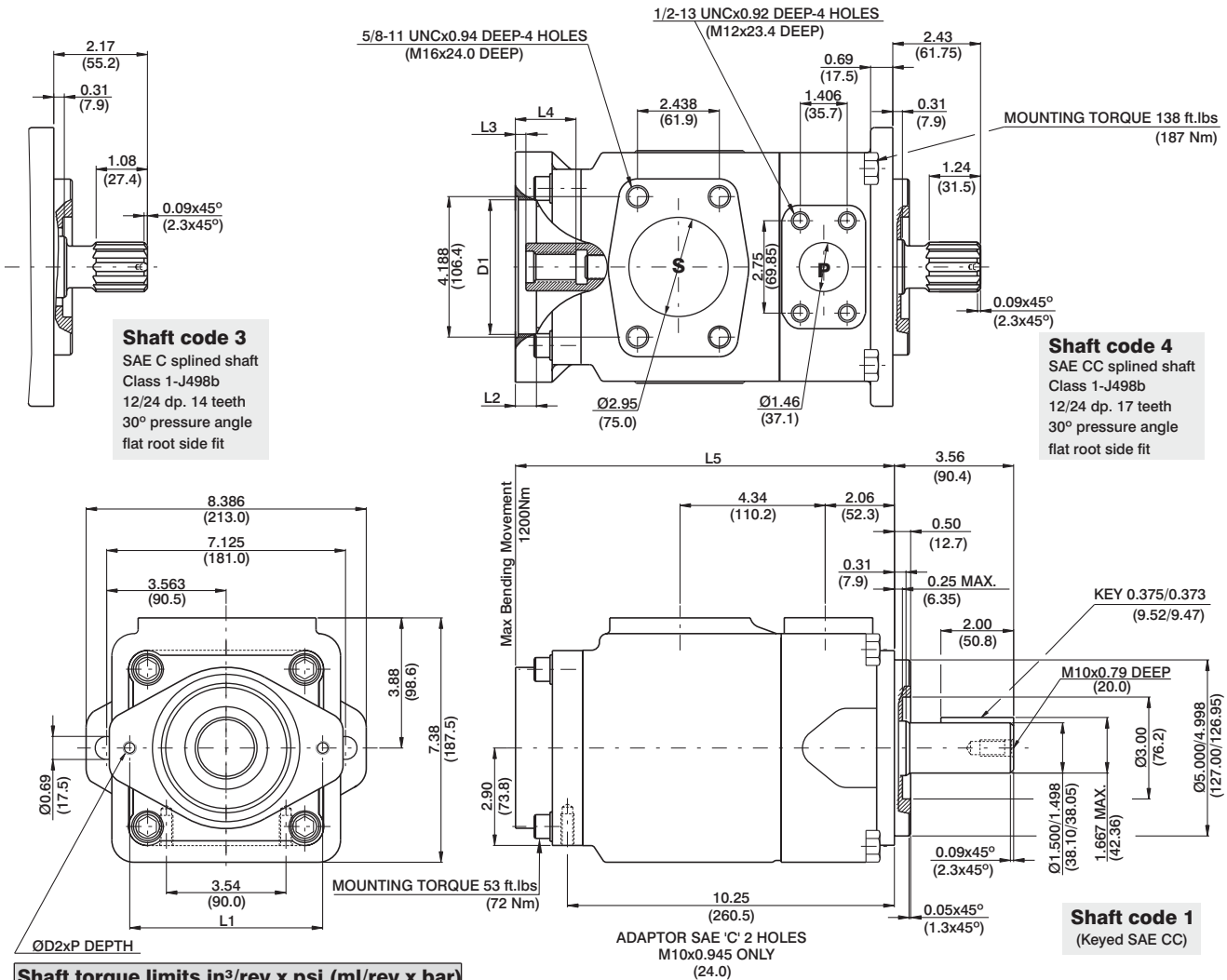

Shaft torque limits in³/rev x psi (ml/rev x bar)

Shaft	V x P max.	Coupling drive	V x P max.
1	71355 (80560)	SAE"A"	9743 (11000)
3	54207 (61200)	SAE"B"	18246 (20600)
4	106474 (120210)	SAE"BB"	28937 (32670)
		SAE"C"	58884 (66480)
		SAE"11teeth"	14039 (15850)

Adaptor	D1	D2	P	L1	L2	L3	L4	L5
SAE "A"	3.25 (82.60)	M10	0.94 (24)	4.19 (106.4)	0.43 (11)	0.31 (7.9)	1.26 (32)	10.71 (272)
SAE "B"	4.00 (101.65)	M12	1.10 (28)	5.75 (146.0)	0.63 (16)	0.31 (7.9)	1.81 (46)	11.26 (286)
SAE "C"	5.00 (127.10)	M16	-	7.12 (181.0)	0.63 (16)	0.31 (7.9)	2.20 (56)	11.65 (296)

Adaptor	SAE "A"			SAE "B"		SAE "C"
	SAE A	SAE (11teeth)	SAE B	SAE B	SAE BB	
Number of teeth	9	11	13	13	15	14
Pitch	16/32	16/32	16/32	16/32	16/32	12/24
Pressure angle	30°	30°	30°	30°	30°	30°
Major dia.(min)	0.625 (15.875)	0.750 (19.05)	0.875 (22.225)	0.875 (22.225)	1.00 (25.40)	1.250 (31.75)
Minor dia.(min)	0.500 (12.70)	0.630 (16.00)	0.753 (19.134)	0.753 (19.134)	0.877 (22.268)	1.086 (27.585)

OPERATING CHARACTERISTICS - TYPICAL (24 cST)

Pressure port	Series	Volumetric Displacement Vp		Flow q & n = 1500 rpm						Input power p & n = 1500 rpm					
				p = 0 bar (0 psi)		p = 140 bar (2000 psi)		p = 240 bar (3500 psi)		p = 7 bar (100 psi)		p = 140 bar (2000 psi)		p = 240 bar (3500 psi)	
		in ³ /rev	cm ³ /rev	gpm	lpm	gpm	lpm	gpm	lpm	hp	kw	hp	kw	hp	kw
VT6ERM	042	8.07	132.3	52.50	198.5	49.87	188.5	47.96	181.3	6.97	5.2	66.25	49.4	110.77	82.6
	045	8.70	142.4	56.51	213.6	53.86	203.6	51.98	196.5	7.24	5.4	70.94	52.9	118.95	88.7
	050	9.67	158.5	62.88	237.7	60.24	227.7	58.36	220.6	7.64	5.7	78.45	58.5	131.82	98.3
	052	10.00	164.8	65.40	247.2	62.75	237.2	60.87	230.1	7.78	5.8	81.53	60.8	136.92	102.1
	057	11.02	180.7	71.71	271.1	69.07	261.1	67.19	254.0	8.18	6.1	89.04	66.4	143.35	106.9
	062	12.00	196.7	78.04	295.0	75.40	285.0	73.52	277.9	8.58	6.4	96.42	71.9	162.67	121.3
	066	13.00	213.3	84.63	319.9	81.98	309.9	80.11	302.8	8.98	6.7	104.20	77.7	175.94	131.2
	072	13.86	227.1	90.11	340.6	87.46	330.6	85.58	323.5	9.25	6.9	110.77	82.6	187.07	139.5
	085 ¹⁾	16.40	269.8	107.00	404.7	105.21 ²⁾	397.7 ²⁾	--	--	9.78	7.3	87.56 ²⁾	65.3 ²⁾	--	--

1) 085 = 2000 RPM max.

2) 085 = 75 bar (1100 psi) cont.

085 = 90 bar (1300 psi) max. int.

VT7EE or VT7EES - 066 - 045 - 1 R 00 - A 1 0 - 00 *

Series

VT7EE series- 250 B4HW
ISO 3019-2 mounting flange

VT7EES series- SAE E 4 bolts
Mounting flange J744c

Cam ring for "P1" & "P2"

Volumetric displacement cm³/rev (in³/rev)

042 = 132.2 (8.07)	057 = 183.2 (11.18)
045 = 142.5 (8.70)	062 = 196.6 (12.0)
050 = 158.5 (9.67)	066 = 213.0 (13.0)
052 = 163.8 (10.0)	072 = 227.1 (13.86)
054 = 170.9 (10.43)	085 = 268.7 (16.40)

Type of shaft VT7EE

2 - keyed G45N(ISO/R775 -G38M)

Type of shaft VT7EES

- 1 - keyed (SAE CC)
- 3 - splined (SAE CC)
- 4 - splined (SAE D & E)
- 5 - splined (SAE D & E)

Modifications

Mounting W/connection variables

P1 & P2= 11"		S=4"
	VT7EES	VT7EE-VT7EES
Type	UNC	METRIC
code	00	M0

Coupling adaptor

- 0 - none
- 2 - SAE B
- 3 - SAE BB

Seal class

- 1 - S1 (for mineral oil)
- 4 - S4 (for fire resistant fluids)
- 5 - S5 (for mineral oil and fire resistant fluids)

Design letter

Porting combination (see page BM-1-5)

00 - standard

Direction of rotation

(view on shaft end)

- R - clockwise
- L - counter-clockwise

INTERNAL LEAKAGE (TYPICAL)

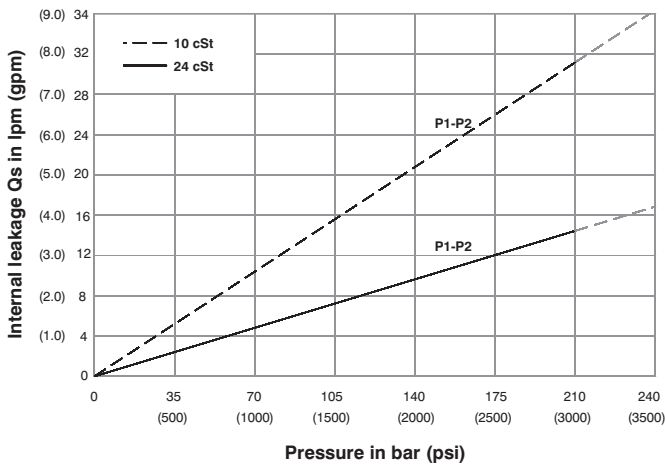

Do not operate pump more than 5 seconds at any speed or viscosity if internal leakage is more than 50% of theoretical flow.
Total leakage is the sum of each section loss at its operating conditions.

NOISE LEVEL (TYPICAL)

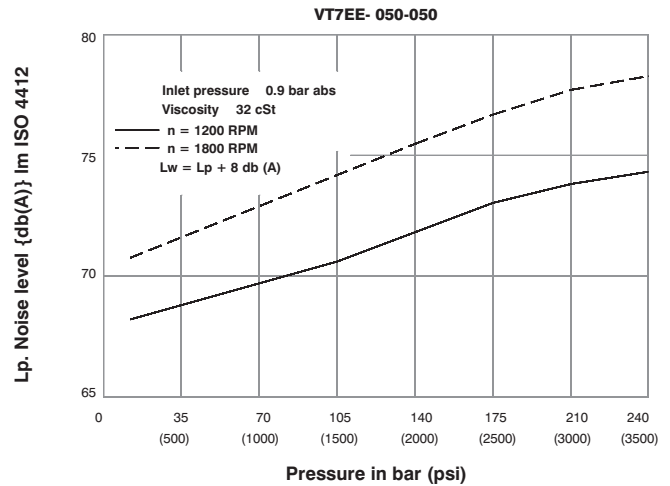

Double pump noise level is given with each section discharging at the pressure noted on the curve.

HYDROMECHANICAL POWER LOSS (TYPICAL)

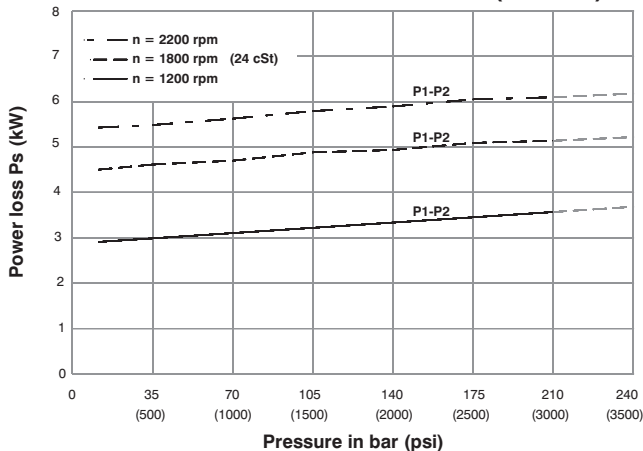

Total hydromechanical power loss is the sum of each section at its operating conditions.

PERMISSIBLE RADIAL LOAD

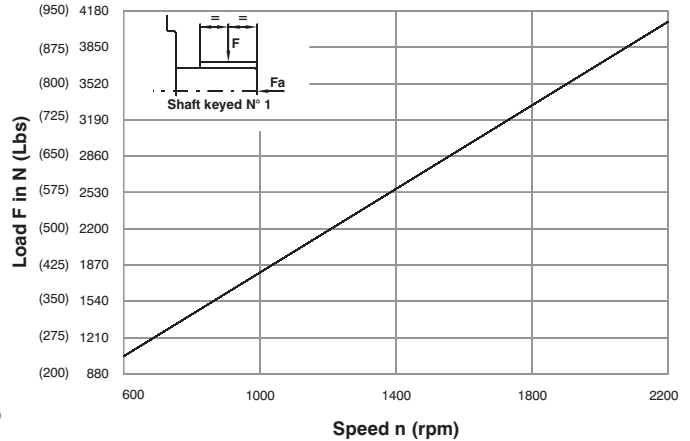

Maximum axial load permissible $F_a = 2000$ N (449 Lbs)



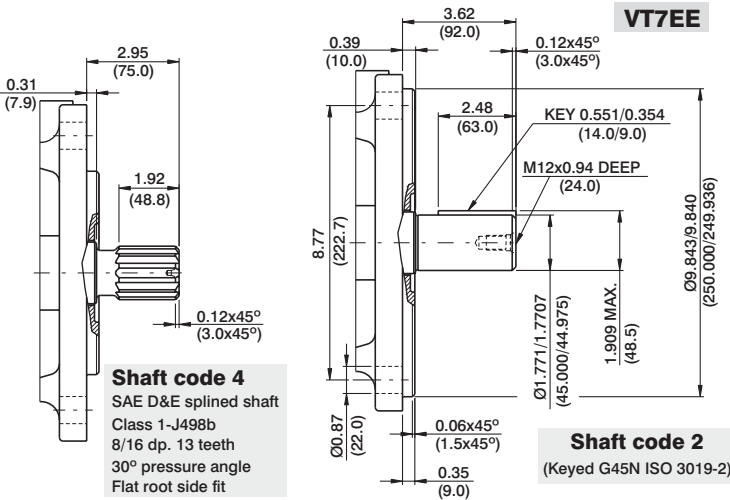
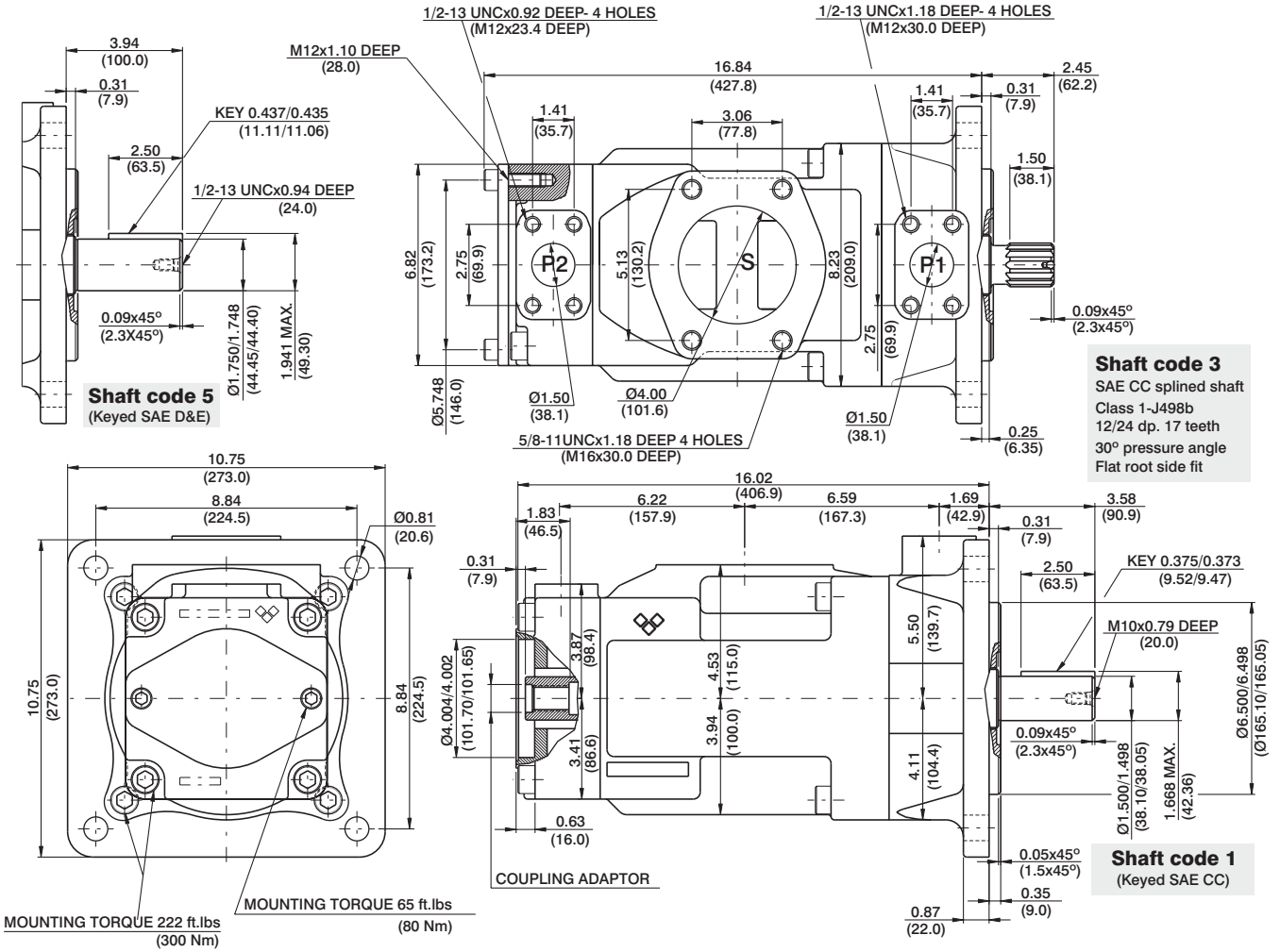

Shaft torque limits in ³ /rev x psi (ml/rev x bar)			
Shaft	Vi x p Max.	Coupling	Vi x p Max.
1	80053 (90380)	SAE-B	18246 (20600)
2	101506 (114600)	SAE-BB	28937 (32670)
3	112312 (126800)		
4	112312 (126800)		
5	104818 (110840)		

Code	Coupling adaptor
0	Without coupling
2	SAE B -13 teeth -pitch 16/32 Major dia (min) 0.875 (22.225) Minor dia (min.) 0.753 (19.126)
3	SAE BB -15 teeth -pitch 16/32 Major dia (min) 1.00 (25.4) Minor dia (min.) 0.877 (22.275)

OPERATING CHARACTERISTICS - TYPICAL (24 cST) (Input power p (KW) for one cartridge only)

Pressure port	Series	Volumetric Displacement Vp		Flow q & n = 1800 rpm						Input power p & n = 1800 rpm					
		in ³ /rev	cm ³ /rev	p = 0 bar (0 psi)		p = 140 bar (2000 psi)		p = 240 bar (3500 psi)		p = 7 bar (100 psi)		p = 140 bar (2000 psi)		p = 240 bar (3500 psi)	
				gpm	lpm	gpm	lpm	gpm	lpm	hp	kw	hp	kw	hp	kw
P1 & P2	042	8.07	132.2	62.92	237.8	60.37	228.2	58.52	221.2	8.09	6.03	78.44	58.49	133.80	99.77
	045	8.70	142.5	67.72	255.9	65.17	246.3	63.32	239.3	8.37	6.24	84.04	62.66	143.60	107.08
	050	9.67	158.5	75.38	284.9	72.83	275.3	70.98	268.3	8.82	6.58	92.97	69.32	159.24	118.75
	052	10.00	163.8	78.37	296.2	75.82	286.6	73.97	279.6	8.99	6.70	96.47	71.94	165.36	123.31
	054	10.43	170.9	81.27	307.2	78.72	297.6	76.87	290.6	9.17	6.84	99.75	74.38	177.46	132.33
	057	11.18	183.2	87.12	329.3	84.57	319.7	82.72	312.7	9.51	7.09	106.57	79.47	189.84	141.56
	062	12.00	196.6	93.54	353.6	90.99	343.9	89.14	336.9	9.88	7.37	114.17	85.13	196.34	146.41
	066	13.00	213.0	101.44	383.4	98.89	373.8	97.04	366.8	10.34	7.71	123.38	92.0	212.46	158.43
	072	13.86	227.1	108.00	408.2	105.45	398.6	103.60	391.6	10.72	7.99	131.04	97.71	225.86	166.42
085	16.40	268.7	127.79	483.0	126.13 ¹⁾	476.7 ¹⁾	--	--	11.88	8.85	101.66 ¹⁾	75.80 ¹⁾	--	--	

1) 085 = 90 bar (1300 psi) max.int.